



Operation Manual
Element LP™
Nitrox System
Rev 02.16

If you have any questions on this equipment please contact Technical Support at:

Nuvair
1600 Beacon Place
Oxnard, CA 93036

Phone: 805-815-4044
FAX: 805-486-0900
Email: info@nuvair.com

Hours: Monday through Friday
8:00 AM to 5:00 PM PST USA

 **Warning**

This Operation Manual contains important safety information and should always be available to those personnel operating this equipment. Read, understand, and retain all instructions before operating this equipment to prevent injury or equipment damage.

Every effort was made to ensure the accuracy of the information contained within. Nuvair, however, retains the right to modify its contents without notice. If you have problems or questions after reading the manual, stop and call Nuvair at 1-805-815-4044 for information.

Table of Contents

Introduction

1.0	Introduction	5
2.0	Safety Warnings.....	6
3.0	Safety and Operation Precautions	8
4.0	Legal Precautions	9
5.0	Theory of Operation	10
6.0	Low Pressure Air Compressor Technical Data	11
7.0	System Components	12
8.0	Nitrox System Specifications	13
9.0	Nitrox System Component Identification.....	14
10.0	System Drawing/Schematic	15
11.0	System Flow Chart	16

Setup, Operation, and Maintenance

12.0	Preparing Existing HP Compressors	17
12.1	Purification System Air/Nitrox Quality.....	17
12.2	Replacement of Compressor Lubricant	17
12.3	Installation of Fill Oxygen Analyzer	18
13.0	Installing the Nitrox System	19
13.1	Precautions	19
13.2	Attaching Compressor Intake Hose	19
13.3	Attaching Nitrogen Discharge Hose (Optional)	20
13.4	Output Pressure Adjustments	21
13.5	Electrical Power Connection	22
13.6	Air/Nitrox Quality Testing	22
14.0	Pre-Operation Instructions	23
14.1	Compressor Oil Levels	23
14.2	Membrane System Regulator and Flow Valve.....	23
14.3	Oxygen Analyzer Calibration.....	24
14.4	Attaching Scuba Cylinder	26
15.0	Producing Nitrox	27
15.1	Flow to Membrane	27
15.2	Setting Proper Pressure	28
15.3	Final Adjustments Before Pumping Nitrox	28
15.4	Pumping Nitrox	29
15.5	Pumping Air	31
15.6	Shutting Down	31
16.0	Nitrox Operational Notes	32
16.1	Correlation of Input Pressure to Oxygen Content	32
16.2	Hot Fills	32
17.0	Maintenance	33
17.1	Daily Maintenance	33
17.2	Routine Maintenance	33
17.3	Compressor Lubricant	35
17.4	LP Filtration	35
17.5	Spare Parts List	37
17.6	Service Record Log	38
Appendix	39
	Supply and Breathing Air Specifications	39
	Filter Element Life Factors	39
	Material Safety Data Sheets	40
	Owner's Warranty Responsibilities.....	42
	Warranty.....	43

Separate Manuals Included:

- Nuvair Pro O₂™ Oxygen Analyzer Operation Manual
- Pick O₂™ Oxygen Analyzer Operation Manual
- Champion R15 Compressor Manual

1.0 Introduction

This manual will assist you in the proper set-up, operation and maintenance of the Nuvair Element LP™ Nitrox System. Be sure to read the entire manual.

Throughout this manual we will use certain words to call your attention to conditions, practices or techniques that may directly affect your safety. Pay particular attention to information introduced by the following signal words:

Danger

Indicates an imminently hazardous situation, which if not avoided, will result in serious personal injury or death.

Warning

Indicates a potentially hazardous situation, which if not avoided, could result in serious personal injury or death.

Caution

Indicates a potentially hazardous situation, which if not avoided, may result in minor or moderate injury. It may also be used to alert against unsafe practices.

Notice

Notifies people of installation, operation or maintenance information which is important but not hazard-related.

2.0 Safety Warnings

Nuvair has taken extreme care in providing you with the information you will need to operate this system. However, it is up to you to carefully read this manual and make the appropriate decisions about system safety.

Warning

This equipment is used to provide breathing gas for the purpose of underwater life support. Read this manual in its entirety. Failure to heed the warnings and cautions contained in this document may result in severe injury or death.

Warning

The equipment you will be using to manufacture Nitrox (oxygen rich air) will expose you to both low and high-pressure gas. Gas, even under moderate pressures, can cause extreme bodily harm. Never allow any gas stream to be directed at any part of your body.

Warning

Any pressurized hose can cause extreme harm if it comes loose or separates from its restraint (or termination) while under pressure and strikes any part of your body. Use appropriate care in making and handling all gas connections.

Danger

Pure nitrogen is a colorless, odorless, tasteless gas that will not support life. Breathing gas mixtures containing more than 84% nitrogen at surface pressures will lead to unconsciousness and may cause death.

Warning

The nitrogen discharge from the Membrane System must be vented to the exterior of any closed building, boat, or similar enclosed space. Breathing gas mixtures containing more than 84% nitrogen at surface pressure will lead to unconsciousness and may cause death.

Warning

Do not use any form of mineral oil or synthetic lubricant not rated for Nitrox in any Compressor in this system. Use only the recommended Nitrox Compressor Lubricant. Never mix the Nitrox Compressor Lubricant with other lubricants. Remove all existing lubricant and replace with the proper Nitrox Compressor Lubricant prior to installing the Membrane System. The use of improper lubricants can lead to fire or explosions, which may cause serious personal injury or death.

Warning

Do not use this system to produce Nitrox mixtures containing more than 40% oxygen. Pumping Nitrox mixtures with higher concentrations of oxygen may lead to fires or explosions, which can cause serious personal injury or death.

 **Warning**

The use of enriched air Nitrox does not eliminate the risk of decompression sickness (DCS) in diving. Decompression sickness can lead to permanent disability or death.

 **Warning**

Do not pump Nitrox mixtures at pressures above the HP Compressor manufacturer's rating, and never above 3600 P.S.I. (250 bar). The system is not rated for pressures above 3600 P.S.I. (250 bar). Higher pressures may lead to explosions which may cause serious personal injury or death.

 **Caution**

Ambient room temperature should never exceed 100°F (38°C) during operation of the Nitrox System. Operation at higher temperatures may lead to system damage and malfunction. A damaged membrane will not produce the correct Nitrox mixture which can lead to severe personal injury if the gas is used for diving purposes without proper analysis.

3.0 Safety And Operation Precautions

Because a compressor is a piece of machinery with moving and rotating parts, the same precautions should be observed as with any piece of machinery of this type where carelessness in operations or maintenance is hazardous to personnel. In addition to the many obvious safety precautions, those listed below must also be observed:

- 1) Read all instructions completely before operating any compressor or Nitrox System.
- 2) For installation, follow all local electrical and safety codes, as well as the National Electrical Code (NEC) and the Occupational Safety and Health Administration (OSHA) standards.
- 3) Electric motors must be securely and adequately grounded. This can be accomplished by wiring with a grounded, metal-clad raceway system to the compressor starter; by using a separate ground wire connected to the bare metal of the motor frame; or other suitable means.
- 4) Protect all power cables from coming in contact with sharp objects. Do not kink power cables and never allow the cables to come in contact with oil, grease, hot surfaces, or chemicals.
- 5) Make certain that power source conforms to the requirements of your equipment.
- 6) Pull main electrical disconnect switch and disconnect any separate control lines, if used, before attempting to work or perform maintenance. "Tag Out" or "Lock Out" all power sources.
- 7) Do not attempt to remove any parts without first relieving the entire system of pressure.
- 8) Do not attempt to service any part while System is in an operational mode.
- 9) Do not operate the System at pressures in excess of its rating.
- 10) Do not operate compressor at speeds in excess of its rating.
- 11) Periodically check all safety devices for proper operation. Do not change pressure setting or restrict operation in any way.
- 12) Be sure no tools, rags or loose parts are left on the Nitrox System.
- 13) Do not use flammable solvents for cleaning the Air Inlet Filters or elements and other parts.
- 14) Exercise cleanliness during maintenance and when making repairs. Keep dirt away from parts by covering parts and exposed openings with clean cloth or Kraft paper.
- 15) Do not operate the compressor without guards, shields, and screens in place.
- 16) Do not install a shut-off valve in the compressor discharge line, unless a pressure relief valve, of proper design and size, is installed in the line between the compressor unit and shut-off valve.
- 17) Do not operate in areas where there is a possibility of inhaling carbon monoxide, carbon dioxide, nitrogen, or flammable or toxic fumes.
- 18) Be careful when touching the exterior of a recently run electric, gasoline, or diesel motor - it may be hot enough to be painful or cause injury. With modern motors this condition is normal if operated at rated load - modern motors are built to operate at higher temperatures.
- 19) Inspect unit daily to observe and correct any unsafe operating conditions found.
- 20) Do not "play around" with compressed air, nor direct air stream at body, because this can cause injuries.
- 21) Compressed air from this machine absolutely must not be used for food processing or breathing air without adequate downstream filters, purifiers and controls and periodic air quality testing.
- 22) Always use an air pressure-regulating device at the point of use, and do not use air pressure greater than marked maximum pressure.
- 23) Check hoses for weak or worn conditions before each use and make certain that all connections are secure.

The user of any compressor or Nitrox System manufactured by Nuair is hereby warned that failure to follow the preceding Safety and Operation Precautions can result in injuries or equipment damage. However, Nuair does not state as fact or does not mean to imply that the preceding list of Safety and Operation Precautions is all-inclusive, and further that the observance of this list will prevent all injuries or equipment damage.

4.0 Legal Precautions

It is highly recommended that a Nitrox fill log be maintained when filling Scuba cylinders to document the following information. This log must be of permanent binding style with no loose pages.

- ◆ Fill date and time of day
- ◆ Tank Number
- ◆ Supplier's check of oxygen content (%O₂) plus signature and date
- ◆ User's check of oxygen content (%O₂) plus signature and date
- ◆ Fill Pressure
- ◆ MOD (Maximum Operating Depth) in user's handwriting
- ◆ Nitrox certifying agency and card number

5.0 Theory of Operation

The Element LP™ Nitrox System is a turnkey package that produces oxygen-rich air (Nitrox) for delivery to the intake of a separate High Pressure (HP) or Low Pressure (LP) compressor. This compressor then compresses the Nitrox to fill Tanks for use at a later time or for direct use by a Diver via Surface Supplied Hoses. Although it is described as the “Nitrox Compressor”, it can also be used to pump air.

The Nitrox System allows for efficient and cost effective Nitrox production using diesel, gas, hydraulic or electric power, without the hazards or expense of blending with stored high-pressure oxygen (O₂). Instead, the system uses a Semi-Permeable Membrane to produce Nitrox from air. A portion of the nitrogen in air is separated out, leaving an oxygen rich Nitrox mixture. This Nitrox mixture can be pumped up to a maximum pressure of 3600 P.S.I. (250 bar) when filling Scuba Cylinders or Storage Tanks.

The Element LP™ uses a Reciprocating Piston LP Air Compressor, Air Aftercooler, Volume Tank, and Filtration to provide the Membrane System with a source of clean, pressurized air for separation. The air is filtered to CGA Grade D or better air quality prior to entering the Membrane System so it will not damage or plug the Membrane fibers. Specifications for Grade D air are provided in the Appendix.

The Element LP™ Membrane System is rated for a maximum supply pressure of 300 P.S.I. (21 bar) and has been configured to work well with the 175 P.S.I. (12 bar) maximum pressure delivered by the LP Air Compressor. An Input Pressure Regulator reduces the pressure to appropriate levels for various %O₂ Nitrox production. The air is then heated to a temperature that provides stability over a wide range of ambient conditions, is optimal for Membrane permeation, and prevents moisture condensation.

The heated air enters the Membrane, which is made up of thousands of miniature hollow fibers. The walls of these fibers are semi-permeable and designed for different gases to move through them (or permeate) at different speeds. The resulting gas mixture is known as the “permeate”. As air flows through the hollow fibers, both oxygen and nitrogen permeate through the fiber walls. The oxygen permeates faster than the nitrogen, which produces permeate with an oxygen content greater than air. The gas that reaches the end of the hollow fibers without permeating is almost entirely nitrogen and is discharged. The flow rate of this discharge is set by the factory via a fixed orifice, which controls the permeate to contain a constant 44% O₂ under normal operating conditions.

The permeate is a concentrated mixture that must be diluted with additional air prior to entering the Nitrox Compressor. It exits the Membrane at ambient to slightly negative pressure and travels into the Mixing Tube, where it mixes homogeneously with filtered outside air. The amount of dilution, and thus final %O₂, is obtained by adjusting the Input Pressure Regulator. As pressure is increased, permeate flow increases, air flow decreases, and a higher %O₂ Nitrox is produced. As pressure is decreased, permeate flow decreases, air flow increases, and a lower %O₂ Nitrox is produced. This relationship between permeate flow and air flow exists because the total of these two flow rates will always equal the intake flow rate demanded by the Nitrox Compressor. The resulting Nitrox mixture is analyzed for %O₂ before entering the Nitrox Compressor for approximate content and again when pumping Nitrox for precise content.

A unique feature of NuVair Nitrox Systems is that the input pressure that correlates to a specific Nitrox %O₂ is repeatable. For example, if your Nitrox Compressor pumps 36% O₂ when the input pressure is at 125 P.S.I. (9 bar), then adjusting the regulator to 125 P.S.I. (9 bar) during the next use will produce the same mixture.

6.0 Low Pressure Air Compressor Technical Data

Capacity and Power Consumption:

Normal working pressure – 80-175 P.S.I. (5.5-12 bar)

Capacity at normal working pressure – 23.5 cfm (666 L/min) Delivery 29.9 cfm (847 L/min)

Displacement

Compressor speed of rotation – 1035 rpm

Maximum working pressure – 175 P.S.I. (12 bar)

Transmission – Belt drive

Cooling

Allowed ambient temperature – 32-104°F (0-40°C)

Aftercooler heat rejection – outlet air temperature reduced to within 20°F (11°C) of ambient

Motor and Electrical Values:

Motor - F class, IP55, 7.5hp (5.5 kW)

Speed of rotation – 1725 rpm

Circuit Breaker Size 230V-50/60 Hz/single phase – 80A

230V-50/60 Hz/three phase – 45A

Compressor current 230V-50/60 Hz/single phase – 34A

230V-50/60 Hz/three phase – 20A

General Technical Data:

Oil Quantity – 2 qt. (1.9 liters)

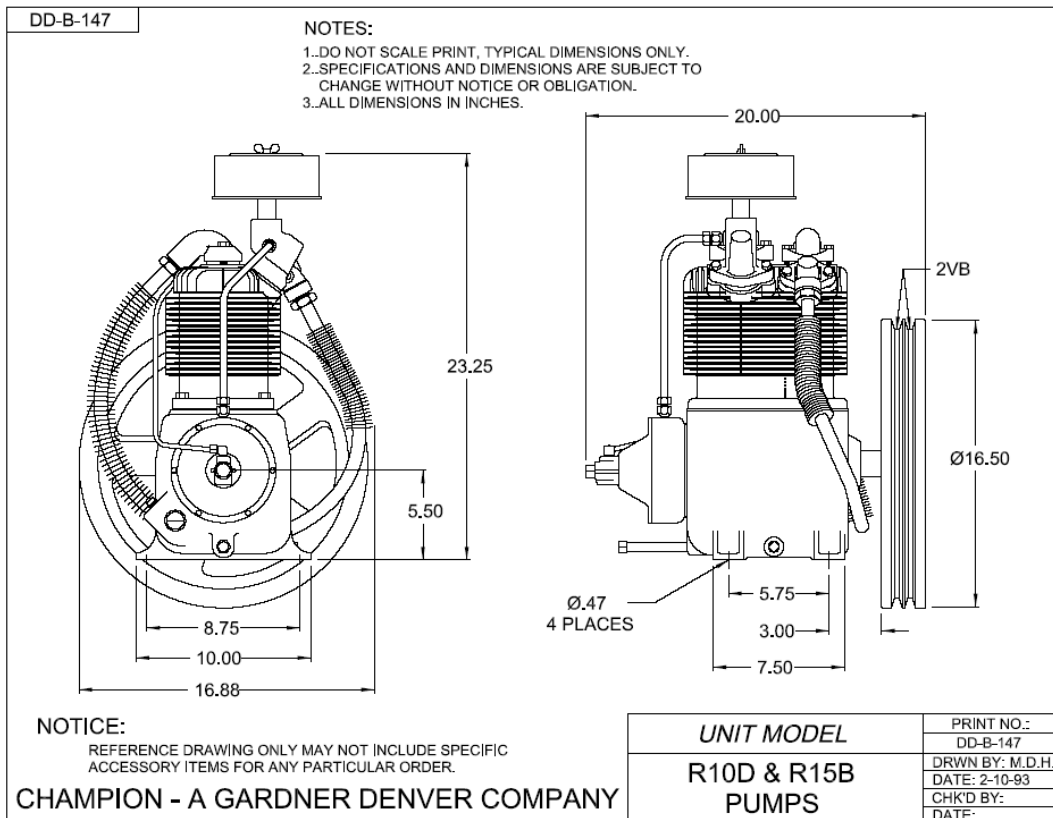

7.0 System Components

- **Champion R15 Low Pressure Air Compressor**
- **7.5 hp (5.5kW) Electric Motor (11 hp Gas, 9 hp Diesel or Hydraulic Power available)**
- **Nitrox Compressor Lubricant:**
 - ◆ **Nuvair 455™ Food Grade Lubricant (standard)**
- **Powder Coated Steel 250 Element Frame with lifting handles & dual isolation vibration mounts (Stainless Steel option available)**
- **Low Pressure Volume Tank – 30 Gallon Horizontal Top Mount standard, other remote configurations available**
- **Volume Tank Pressure Gauge**
- **On/Off Flow Ball Valve**
- **Input pressure>Low Pressure Regulator with Pressure Gauge:**
 - ◆ **Pressure Input to regulator 80-175 P.S.I. (5.5-12 bar)**
 - ◆ **Low Pressure>Low pressure regulator, Input Pressure 165-300 P.S.I. (11-20 bar) (Low Pressure Supply Option)**
 - ◆ **Output Pressure from regulator 80-175 P.S.I. (5.5-12 bar) depending on HP or LP “Nitrox” Compressor size and Nitrox %O₂**
- **Low Pressure Inlet Filtration, Grade D Breathing Air, including four stages:**
 - ◆ **Particle Removal to 1 micron, auto drain, liquid level indicator**
 - ◆ **Coalescing, Water & Oil Vapor Removal to 0.01 micron, auto drain, liquid level & service life indicators**
 - ◆ **Oil Vapor Removal to 0.003 PPM**
 - ◆ **Final Stage Carbon Particle Removal, auto drain, liquid level & service life indicators**
- **Heater including:**
 - ◆ **110/220 Volt 5 Amp**
 - ◆ **Thermostat Control**
 - ◆ **Digital Temperature Gauge**
 - ◆ **Pressure Switch**
 - ◆ **200 P.S.I. (14 bar) ASME Over Pressure Relief**
- **Semi-Permeable Membrane**
- **Mixing Tube & Air Intake Filter**
- **Pick O₂™ Inline Oxygen Analyzer**
- **Compressor Intake Hose**
- **Nitrogen Discharge Hose (optional)**
- **Nuvair Pro O₂™ Fill Oxygen Analyzer, including:**
 - ◆ **High Pressure>Low pressure regulator**
 - ◆ **Flow Restrictor, 1 - 5 L/min**
- **Hour Meter (Electric & Gas Powered only)**
- **Air/Nitrox Quality Analysis Kit**

8.0 Nitrox System Specifications

Physical Specifications	Height	44 in (112 cm)
	Width	44 in (112 cm)
	Depth	23 in (58 cm)
	Weight	400-510 lb (182-232 kg)
Full Load Amps	230V/E3/50-60 Hz	25A
	230V/E1/50-60 Hz	39A
Membrane Input	Operating Pressure Range	80-175 psi (5.5-12 bar)
	Maximum Input Pressure	300 psi (21 bar)
	Supply Air Volume Range	8-25 scfm (212-708 L/min)
	LP Supply Air Quality	Grade D
	Optimum Temperature	110 +/- 5°F (43 +/- 3°C)
	Nitrox %O ₂ Range	24 - 40%

Nitrox Compressor Recommendations

		To Pump Nitrox with 24-40%O ₂	To Pump Nitrox with 24-32%O ₂
HP Nitrox Compressors	Charging Rate	6-10 scfm (170-283 L/min)	6-15 scfm (170-427 L/min)
	Horsepower – Electric	5-7.5 hp (3.8-5.6 kW)	5-15 hp (3.8-11 kW)
	Horsepower – Gas	6.5-11 hp (4.9-8.3 kW)	6.5-18 hp (4.9-14 kW)
	Horsepower – Diesel	9-10 hp (6.8-7.5 kW)	9-18 hp (6.8-14 kW)
LP Nitrox Compressors	Delivery @ 175 P.S.I. (12 bar)	N/A	10-15 scfm (283-427 L/min)
	Horsepower – Electric	N/A	5 hp (3.8 kW)
	Horsepower – Gas	N/A	9 hp (6.8 kW)
	Horsepower – Diesel	N/A	9 hp (6.8 kW)

9.0 Nitrox System Component Identification

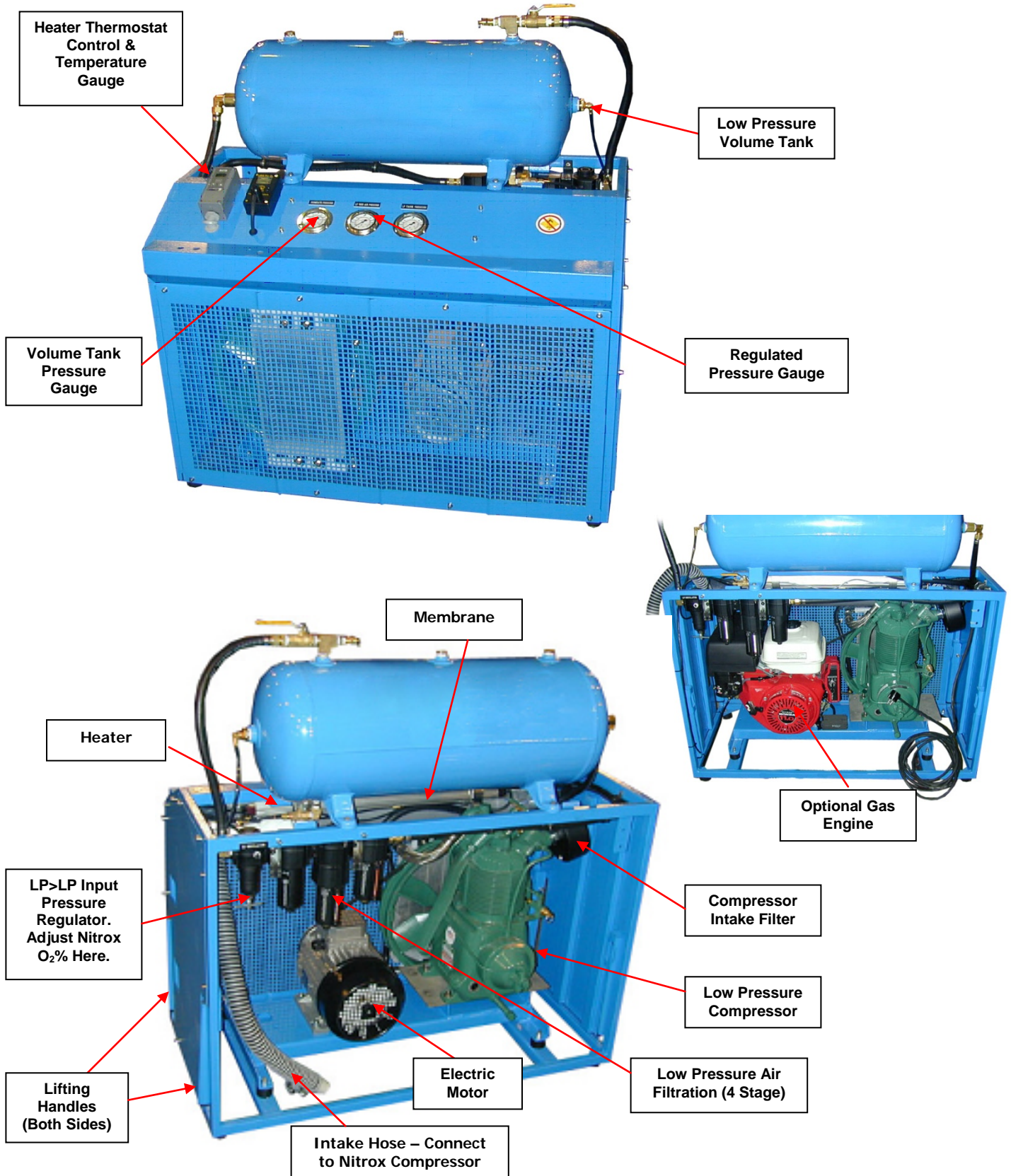

10.0 System Drawing/Schematic

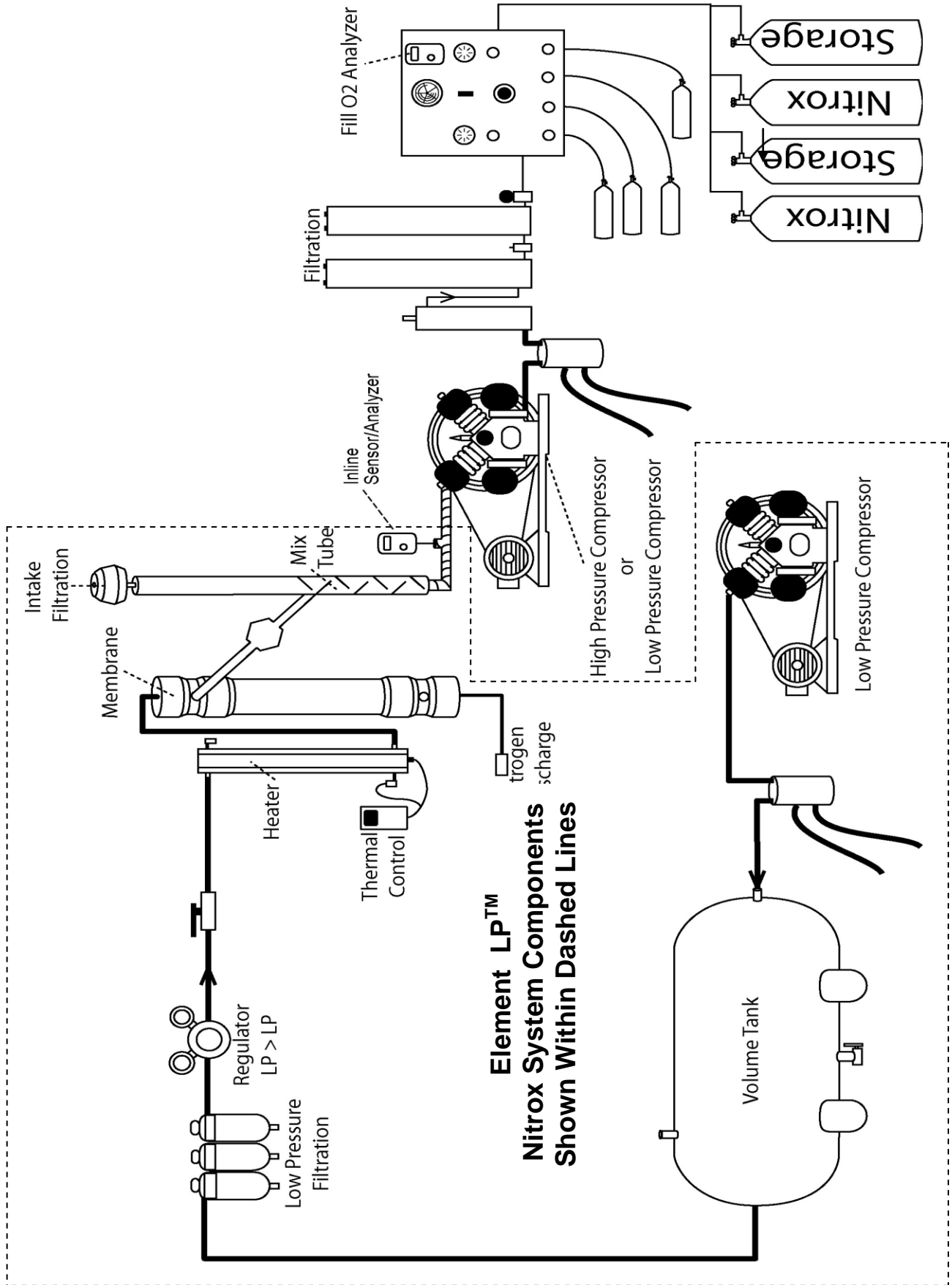

11.0 System Flow Chart

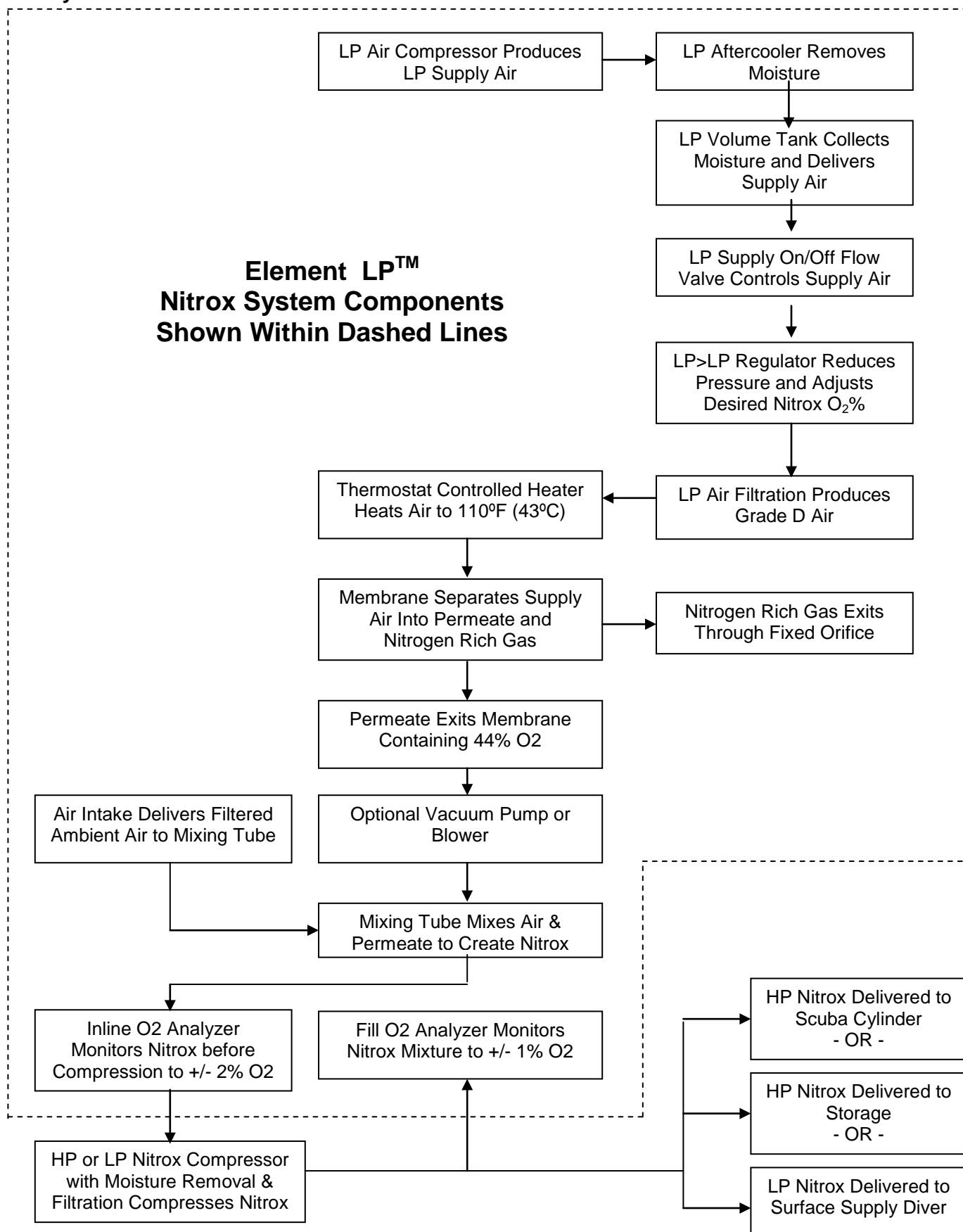

12.0 Preparing Existing Compressors

Warning

Some compressors are not suitable for compressing oxygen-rich air, i.e., Nitrox. Use of an unsuitable compressor may lead to possible compressor damage and/or fires or explosion. This can lead to serious personal injury or death. If there is any doubt regarding the use of an existing compressor, contact Nuvair or the compressor manufacturer before you connect your Nitrox System to your machinery.

12.1 Purification System

The purification system on the existing compressor to which the Nitrox System will be installed must produce breathing air appropriate for diving use. LP compressors must meet the CGA Grade D standard, and HP compressors must meet the Grade E standard. These are the same standards applied to all breathing air compressors. Please make sure you place extra caution on timely replacement of the filters in the purification system to ensure these standards at all times. Specifications for Grade D and E air are provided in the Appendix.

A recent air quality test from your existing compressor is highly recommended prior to installing the Nitrox System. After installation, test a Nitrox sample using the Air/Nitrox Quality Analysis Kit provided. Quarterly testing is mandatory once the System is operational.

Caution

Breathing air compressors must produce breathing air appropriate for diving use in accordance with the appropriate CGA Grade. Periodic air quality testing is mandatory to assure compliance.

12.2 Replacement of Compressor Lubricant

For an existing compressor to be used with the Nitrox System, all traces of old lubricant must be removed and replaced with Nitrox Compressor Lubricant. Nitrox Compressor Lubricant is compatible with both air and Nitrox.

- 1) Start compressor and run for 10 minutes to warm compressor lubricant. Shut off compressor, remove lubricant, and replace lubricant Filter if any.
- 2) Refill compressor with the Nuvair Air/Nitrox Compressor Lubricant supplied. Do not overfill.
- 3) After 10 hours, repeat Steps 1 and 2.



Nuvair™ 455
Food Grade Air &
Nitrox Compressor
Lubricant (Standard)



Nuvair™ 751
Diester Based Air &
Nitrox Compressor
Lubricant (Optional)

 **Caution**

After running the compressor, the lubricant will be very hot. Take care when removing the drain plug and draining the lubricant to avoid burns.

 **Notice**

Recommended Nitrox Compressor Lubricant change intervals after the 10-hour flush are at 25, 50, and 100 hours. After reaching 100 hrs, change lubricant in 100 hour cycles.

 **Caution**

Wear gloves when handling compressor lubricant. If contact with skin is made, wash the skin surface with soap and water.

 **Caution**

Always wear goggles when handling compressor lubricant. These materials can cause eye irritation. If you accidentally get lubricant into your eyes, flush with fresh water for 15 minutes and contact a physician if irritation develops.

 **Caution**

Compressor lubricant should be incinerated after use in a licensed facility in accordance with Federal, State, and local regulations.

12.3 Installation of Fill Oxygen Analyzer

The Fill Oxygen Analyzer is installed at the final Nitrox outlet (compressor fill whip, Fill Panel, etc.) to monitor oxygen content. A sample stream of Nitrox is delivered to the analyzer to provide accurate results and prevent damage to the analyzer. A regulator and flow restrictor are used to control the pressure and flow of the sample stream. After installation, always use the Fill Oxygen Analyzer when pumping either Nitrox or air to ensure proper oxygen content.

 **Warning**

Never expose the Oxygen Analyzer sensor to pressures other than ambient or you may damage it and/or cause false readings. A damaged sensor will not provide accurate gas analysis. Inaccurate gas analysis can lead to serious personal injury or death when the gas mixture that was analyzed is used for breathing.

For use on a HP compressor system, the Nitrox sample stream is obtained at the fill whip location on the compressor or Fill Panel. Tap into the fill whip manifold or install a HP Tee fitting, then attach the inlet of the Regulator/Flow Restrictor Assembly using HP hose and fittings as required (hose and fittings not included). Mount the Fill Oxygen Analyzer in a secure location, then attach the outlet of the Regulator/Flow Restrictor Assembly to the analyzer using the hose provided.

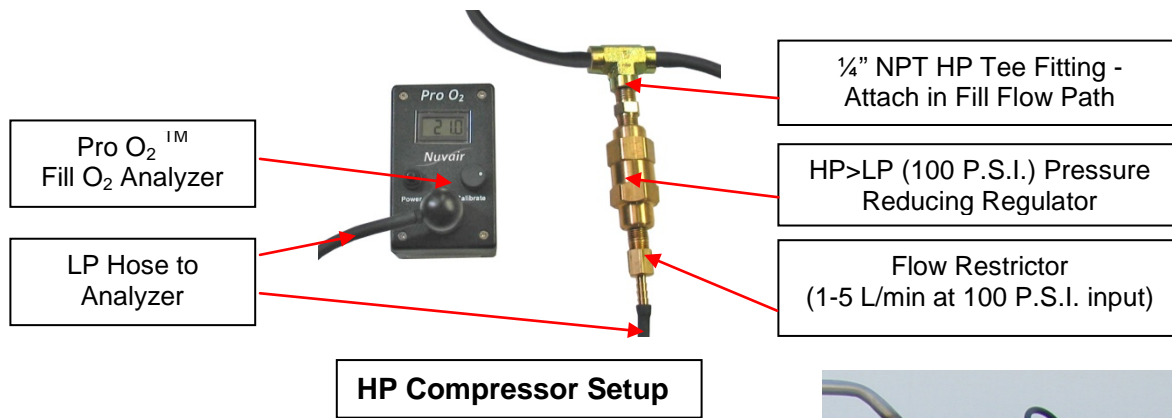

For use on a LP compressor system, it is important to sample the final flow just before the diver manifold. The sample stream is typically obtained at the LP Volume Tank outlet. The stream is routed to the Flow Restrictor and from there to the Fill Oxygen Analyzer. There are a wide variety of LP compressor systems in use, so contact Nuvair for detailed instructions.



LP Compressor Setup

13.0 Installing the Nitrox System

Notice

If any information in this manual conflicts with any of the other manuals call our headquarters at 805-815-4044 before proceeding.

13.1 Precautions

- 1) Please read all information supplied before physically installing the Nitrox System.
- 2) Unpack the system and remove from the pallet. Visually inspect the system to make sure there has been no damage during shipping. If damaged, please call Nuvair to file a damage report. Please take photos and supply detailed information about the damage.
- 3) Place the system in a permanent location near the existing compressor. Allow a minimum spacing of 18" from adjacent walls. Select a location where ambient room temperature will never exceed 105°F (40°C).
- 4) The Heater Thermostat has been set in the factory. Do not adjust.
- 5) A 13 foot corrugated compressor Intake Hose has been provided to connect the Nitrox System to the HP compressor intake. If a longer hose is required, the diameter must also be increased. Contact Nuvair for assistance.

13.2 Attaching Compressor Intake Hose

- 1) Cut the Intake Hose to proper length to reach between the Nitrox System and Nitrox Compressor. Reattach end fittings
- 2) Attach the Intake Hose to the Nitrox System outlet.
- 3) Attach the other end of the Intake Hose to the intake of the Nitrox Compressor and secure with the hose clamp provided.

⚠ Caution

Do not use a compressor Intake Hose longer than 13 feet to connect the Nitrox System to the compressor intake. Use of a longer hose will increase the amount of suction the compressor must generate which can cause overheating and damage to the compressor. Damaged compressors can pump impurities into the diver's breathing gas.

⚠ Caution

Do not substitute a compressor intake hose of a smaller diameter than the supplied by Nuair. Use of a smaller diameter hose will increase the amount of suction the compressor must generate which can cause overheating and damage to the compressor. Damaged compressors can pump impurities into the diver's breathing gas.

Attach this End of Intake Hose to Compressor Intake

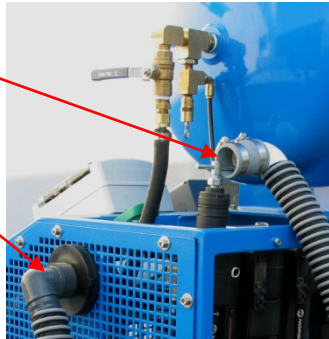

Attach This End of Intake Hose to Nitrox System Outlet

Secure Hose to Nitrox Compressor Intake with Hose Clamp as shown on this Coltri HP Compressor.

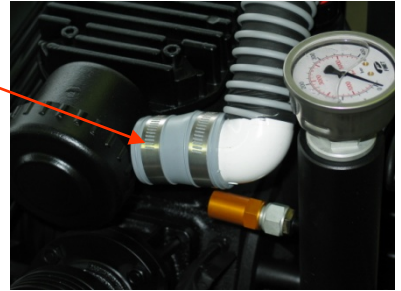

Fixed Factory Set Nitrogen Discharge

13.3 Attaching Nitrogen Discharge Hose (Optional)

The nitrogen discharge from the Membrane must be isolated from the air intakes of the Membrane System and LP Compressor. This requirement will be met if the Nitrox System is installed in a well-ventilated room that meets industry standards for compressor installations. If the Nitrox System is installed in a closed building, boat, or similar enclosed space, the nitrogen discharge must be vented to the outside. An optional Nitrogen Discharge Hose may be needed. If your installation requires the use of a Nitrogen Discharge Hose, please contact Nuair for assistance.



⚠ Danger

Pure nitrogen is a colorless, odorless, tasteless gas that will not support life. Breathing gas mixtures containing more than 84% nitrogen at surface pressures will lead to unconsciousness and may cause death

⚠ Warning

The nitrogen discharge from the Membrane should be vented to a well-ventilated room or to open air with good circulation. Failure to isolate the discharge from the air intake of the Membrane System or LP compressor could lead to incorrect Nitrox mixtures, resulting in serious personal injury or death. If you allow this pure nitrogen to accumulate in an enclosed space, anyone entering this space will quickly lose consciousness and will die if not immediately resuscitated.

13.4 LP Air Compressor Output Pressure Adjustments

The LP Air Compressor pressure output has been factory set to pump up to 175 P.S.I. (12 bar), where the valves unload and compression stops. As air is consumed, the pressure drops down to a low pressure of approximately 165 P.S.I. (11 bar), where the valves reload and compression starts again. This cycle is known as the compressor differential pressure.

- **This output setting allows the Nitrox System to be used with a HP or LP Compressor having a rated capacity up to 8 cfm (228 L/min) at 40% O₂ or up to 15 cfm (427 L/min) at 32% O₂ production.**

If your compressor is smaller, the inlet pressures required for the Membrane System may be lower. It will then be beneficial to lower the compressor differential pressure accordingly. The low side differential pressure must always be at least 5 P.S.I (0.3 bar) higher than the Membrane inlet pressure necessary to produce Nitrox with 40% O₂.

Follow the directions in your LP Air Compressor manual to make this adjustment.

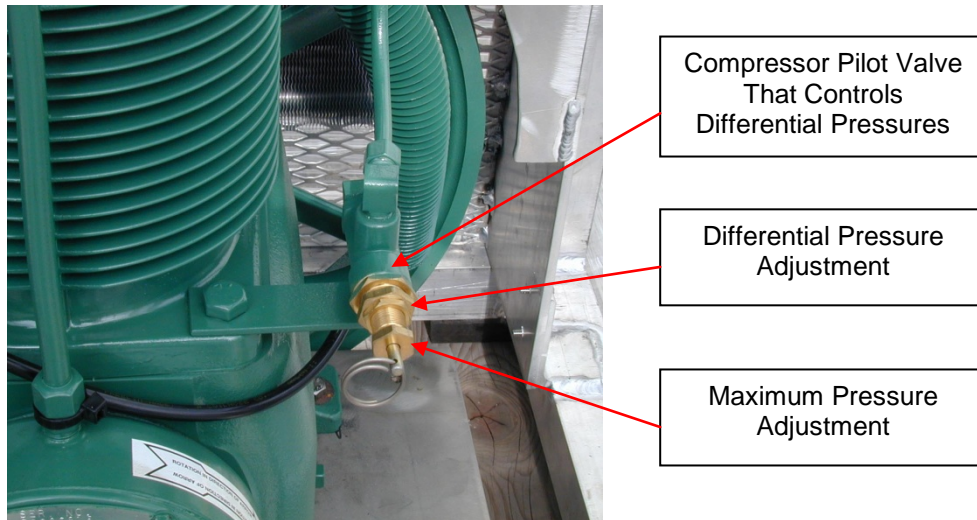

13.5 Electrical Power Connection

Warning

Never use extension cords to provide power to your Nitrox System. The system must be properly wired according to national and local electrical codes by a qualified electrician. Improper wiring may lead to fires, which can cause serious personal injury or death.

Electrical wiring and connections should be made by a qualified electrician in accordance with all national and local electrical codes. Check all System Specifications provided in this manual. When working on the Nitrox System the main breaker at the power source must be “locked out” in the Off position.

Note Proper Direction of Rotation

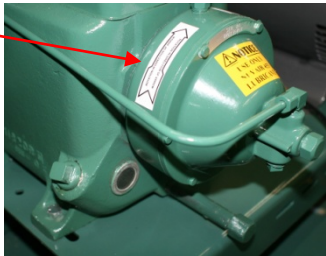

Amperage Load for System

- ◆ Approximately 25 A for 230 V three phase service
- ◆ Approximately 39 A for 230 V single phase service

LP Compressor Rotation Check

Always turn on (bump) starter and run motor very briefly to check for proper direction of rotation (see arrow on belt guard and flywheel).

Notice

Operation in reverse direction for extended periods of time will cause a Reciprocating Compressor to run hot and perform poorly and may cause permanent damage.

The Nitrox System has electrical protection for the compressor Motor and Membrane System Heater located inside the motor starter.

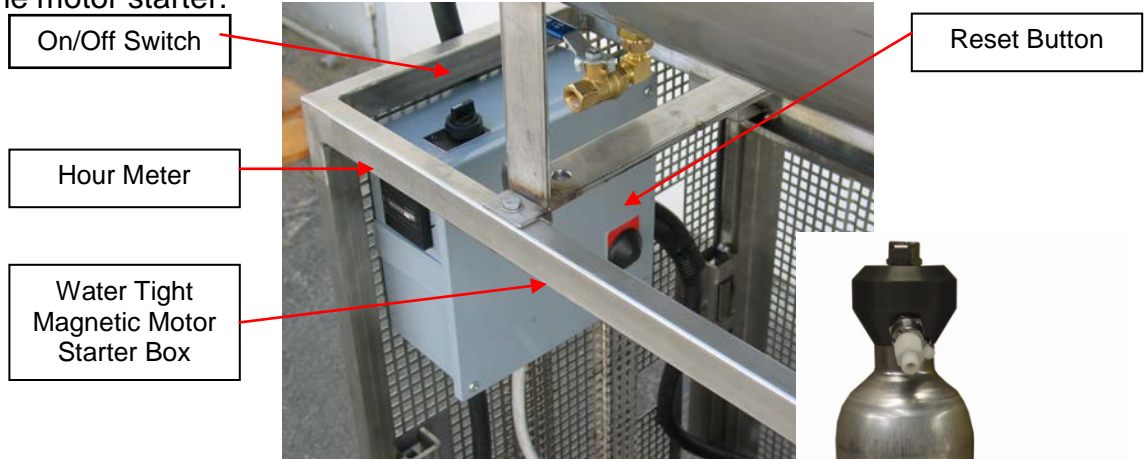

13.6 Air/Nitrox Quality Testing

Before using your Nitrox System and HP compressor to pump Nitrox, test a sample of the Nitrox produced using the Air/Nitrox Quality Analysis Kit provided to verify compliance with CGA standards. Quarterly testing is mandatory once the System is operational.



14 Pre-Operation Instructions

Warning

Do not allow Nitrox to be discharged into the air storage system. Nitrox introduced into the air storage system could cause a diver to suffer from oxygen poisoning at depth. Oxygen poisoning is extremely dangerous and can lead to drowning.

Warning

Do not allow air to be discharged into the Nitrox storage system. Air introduced into the Nitrox storage system could cause a diver to suffer decompression sickness if the Nitrox mixture is not analyzed properly and is used underwater under the assumption it is a different mix.

14.1 Compressor Lubricant Levels

Check lubricant levels before starting the LP Air Compressor and the Nitrox Compressors, and add lubricant as required. Use only the lubricants specified.

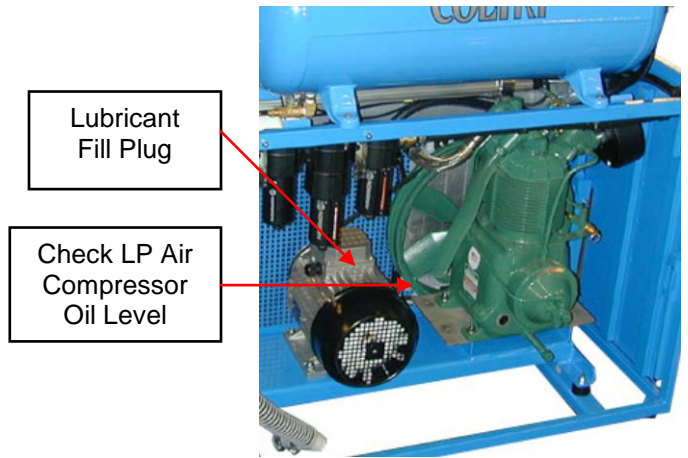

14.2 Membrane System Regulator and Flow Valve

A LP regulator is used to reduce supply pressure to the Membrane System to a typical range of 80 – 175 P.S.I. (5.5-12 bar). An On/Off Flow Valve is used to control the flow of LP supply air into the Membrane System. Prepare the Membrane System as follows:

- 1) Reduce input pressure to minimum pressure setting by turning the regulator adjustment knob counter-clockwise (CCW) until it spins freely.
- 2) Turn regulator knob clockwise (CW) until you first feel resistance, which means that the spring is starting to compress.
- 3) Make sure the LP Supply Air On/Off Flow Valve is in the Off position.

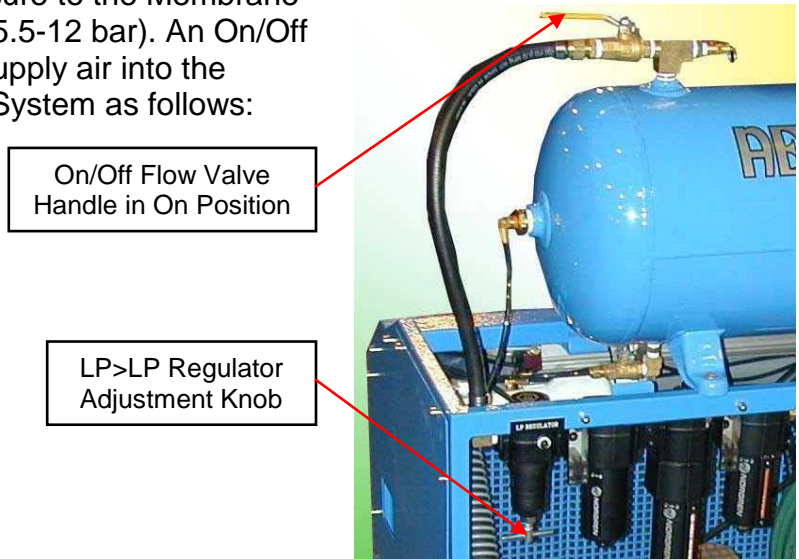

14.3 Oxygen Analyzer Calibration

Gas production may be monitored with the Inline Oxygen Analyzer before entering the Nitrox Compressor to obtain a rough estimate of %O₂ (+/- 2%); however, do not rely on this reading as an indication of %O₂ at the Nitrox Compressor outlet. Prior to pumping Nitrox into a Scuba cylinder or Surface Supply System, it must be monitored with the Fill Oxygen Analyzer to obtain a precise measurement of %O₂ (+/- 1%). Both Oxygen Analyzers must be calibrated prior to each use.

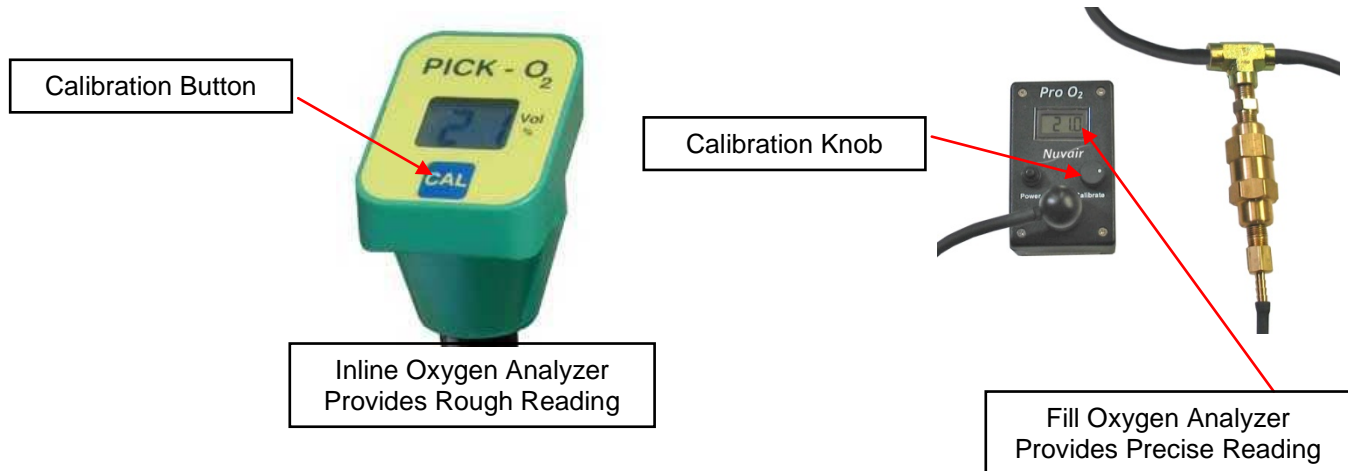

Warning

Oxygen Analyzers must be calibrated before each use. See Oxygen Analyzer manuals for correct calibration procedures. Improper calibration of the Fill Oxygen Analyzer may result in the use of incorrect Nitrox mixtures, which may cause serious injury or death to the diver using the gas mixture.

Warning

At altitudes above sea level, a correction factor must be used when calibrating the Fill Oxygen Analyzer may not be achievable. See Fill Oxygen Analyzer manual for correcting analyzer readings at various altitudes. Improper calibration of the Fill Oxygen Analyzer may result in the use of incorrect Nitrox mixtures, which may cause serious injury or death to the diver using the gas mixture.

Warning

The Permeate Oxygen Analyzer supplies oxygen readings that can vary +/- 2% O₂ due to heat, humidity, and pressure changes experienced in the Nitrox flow and therefore should only be used for rough estimates of %O₂. The Fill Oxygen Analyzer supplies more accurate oxygen readings, within +/- 1% O₂. For Scuba cylinder Nitrox fills, the user must always verify the final fill with a third independent Oxygen Analyzer.

Calibrate Oxygen Analyzers as follows:

High Pressure Nitrox Compressor System

- 1) Close Membrane System On/Off Flow Valve and return LP regulator to minimum pressure setting by turning adjustment knob CCW until it spins freely.
- 2) Slightly open fill whip valve on HP Nitrox Compressor to relieve any residual pressure, and then, if desired, insert clean rag in yoke to act as sound muffler.

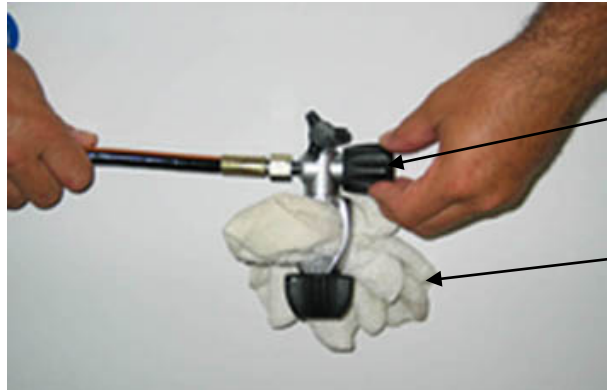

Adjust fill whip
Valve to Maintain
Pressure

Insert Clean Rag
in fill whip Yoke

Optional Sound Muffler for HP Nitrox Compressor

- 3) Turn on HP Nitrox Compressor according to manufacturer's instructions.
 - 4) Adjust fill whip valve so the running compressor maintains 1500-2000 P.S.I. (100-140 bar) outlet pressure. Air will now be flowing past both Oxygen Analyzers for calibration purposes.
 - 5) Monitor all gauges for proper operating range and check all connections for leaks.
 - 6) Calibrate Oxygen Analyzers while the Nitrox Compressor is pumping air. Refer to the Oxygen Analyzer manual included with the Nitrox System for details. Note that special calibration procedures may be required when operating at altitudes above sea level.
- ◆ Inline Oxygen Analyzer - Calibrate analyzer so Display reads 21%.
 - ◆ Fill Oxygen Analyzer - Calibrate analyzer so Display reads 20.9% to correlate with the Grade E breathing air present at the Sensor. Different settings may be used depending on location, so verify your actual ambient conditions and refer to the Oxygen Analyzer manual for details.

Low Pressure Nitrox Compressor System

- 1) Close Membrane System On/Off Flow Valve and return LP regulator to minimum pressure setting by turning adjustment knob CCW until it spins freely.
 - 2) Slightly open bleed or dump valve on Surface Supply divers manifold to relieve any residual pressure.
 - 3) Turn on LP Nitrox Compressor according to manufacturer's instructions.
 - 4) Adjust valve flow so the running compressor maintains 80-120 P.S.I. (6-8 bar) outlet pressure. Air will now be flowing past both Oxygen Analyzers for calibration purposes.
 - 5) Monitor all gauges for proper operating range and check all connections for leaks.
 - 6) Calibrate Oxygen Analyzers while the Nitrox Compressor is pumping air. Refer to Oxygen Analyzer manuals included with Membrane System for details. Note that special calibration procedures may be required when operating at altitudes above sea level.
- ◆ Inline Oxygen Analyzer - Calibrate analyzer so Display reads 21%.
 - ◆ Fill Oxygen Analyzer - Calibrate analyzer so Display reads 20.9% to correlate with the Grade E breathing air present at the Sensor.

Fill Oxygen Analyzer - Alternate Calibration Method

The Fill Oxygen Analyzer can also be calibrated in ambient air as an alternative. This is especially useful during routine re-calibration while the system is operating. Different settings may be used depending on location, so verify your actual ambient conditions and refer to the Oxygen Analyzer manual for details.

- 1) Remove the Flow Adapter Cap covering the Sensor.
- 2) Expose the Sensor to ambient air for approximately 15 seconds.
- 3) Adjust Calibration Knob until Display reading stabilizes at 20.9%.
- 4) Reinstall the Flow Adapter Cap to the analyzer.
- 5) The Fill Oxygen Analyzer is now ready for use.



Calibration Knob

Sensor Cap Removed

14.4 Attaching Scuba Cylinder

If using a HP Nitrox Compressor, attach one fill whip to a Scuba Cylinder. Leave cylinder valve closed.

Fill Whip Attached to Scuba Cylinder



Notice

Only one fill whip is attached to a Scuba Cylinder at this point. The second whip will continue to be used to control HP Compressor outlet pressure.

Additional cylinders or storage tanks can be attached after the system is ready to pump Nitrox.

15.0 Producing Nitrox

Warning

The equipment you will be using to manufacture Nitrox (oxygen rich air) will expose you to both low and high-pressure gas. Gas, even under moderate pressures, can cause extreme bodily harm. Never allow any gas stream to be directed at any part of your body.

15.1 Flow to Membrane

- 1) Verify that Oxygen Analyzer calibration is complete, Make sure the LP Feed Air Supply Valve is in the Off position, and Regulator is set to the minimum pressure setting.
- 2) Turn on LP Air Compressor using On/Off Switch and allow Volume Tank to come up to full pressure of approximately 175 P.S.I. (12 bar). The sound will change and the rpm will increase slightly, indicating that the compressor is unloading.
- 3) Turn on Nitrox Compressor:
 - HP compressor - Allow outlet pressure to build up to about 2000 P.S.I. (140 bar), then crack open the unconnected fill whip to maintain 1500-2000 P.S.I. (100-140 bar).
 - LP compressor - Allow outlet pressure to build up to approximately 120 P.S.I. (8 bar), then crack open bleed or dump valve to maintain 80-120 P.S.I. (6-8 bar)
- 4) Verify that Inline Oxygen Analyzer reads 20.9%.
- 5) Turn on Membrane System by slowly opening LP Feed Air Supply Valve.
- 6) Adjust input pressure to approximately 100 P.S.I (7 bar) to activate Heater Pressure Switch. Increase pressure by slowly turning the regulator Knob CW or decrease pressure by turning the Knob CCW. Heater will not turn on until Membrane System is pressurized to above 80 PSI.
- 7) Verify that Heater Thermostat Control green indicator light is on. The light will remain on until operating temperature is reached and will then cycle on and off. When light turns off, check Heater Temperature Gauge to verify air temperature is between 105-120 °F (40-49 °C). At any time that temperature exceeds 120 °F, green indicator light should be off.

LP Air Compressor On/Off Switch



On/Off LP Feed Air Supply Valve Handle in Open Position



LP>LP Feed Regulator

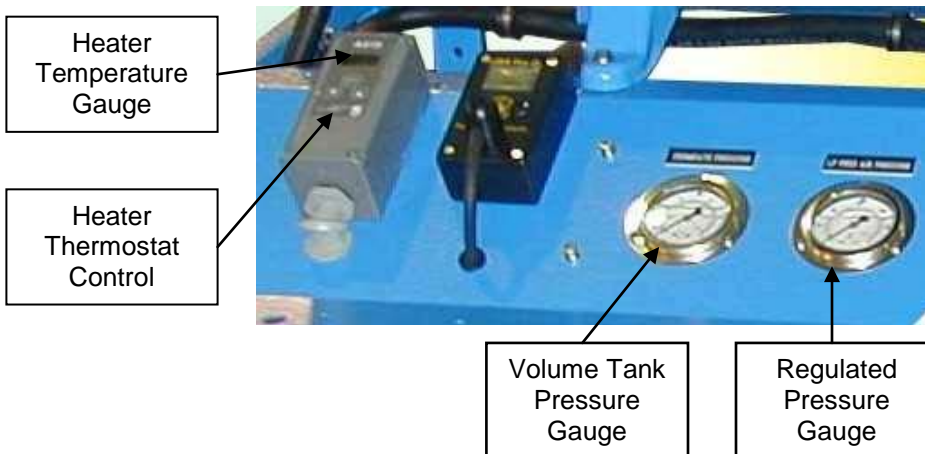

⚠ Notice

The Heater Thermostat Control green indicator light will stay on until operating temperature is reached.

⚠ Caution

Do not change the temperature setting on the Thermostat Control without contacting Nuair. Changes in temperature settings may cause Membrane damage. A damaged membrane will not produce the correct Nitrox mixture which can lead to severe personal injury if the gas is used for diving purposes without proper analysis.

15.2 Setting Proper Pressure

The input pressure to the Membrane System determines the %O₂ of the Nitrox mixture produced. As input pressure is increased, a higher %O₂ Nitrox is pumped. As pressure is decreased, a lower %O₂ Nitrox is pumped.

- 1) Increase input pressure by slowly turning the regulator Knob CW while monitoring the Pressure Gauges and Inline Oxygen Analyzer. As the pressure rises, watch the corresponding increase in the analyzer %O₂ reading.
- 2) Increase or decrease pressure slowly until the Inline Oxygen Analyzer displays the %O₂ desired in the final Nitrox mixture.
- 3) Allow system pressure and temperature to stabilize (approximately 5-8 minutes).
 - ◆ Volume Tank pressure range should be 165-175 P.S.I. (11-12 bar).
 - ◆ Regulated Membrane System pressure range should be 80– 165 P.S.I (6-11 bar), depending on Nitrox %O₂ being produced.
 - ◆ Heater temperature range should be 105-120 °F (40-49 °C).



Inline Oxygen Analyzer

⚠ Notice

Feed air pressure will never be higher than Volume Tank pressure.

15.3 Final Adjustments Before Pumping Nitrox

- 1) As the Nitrox initially makes its way through the running Nitrox Compressor, the %O₂ reading on the Fill Oxygen Analyzer will slowly increase to read approximately the same %O₂ as the Inline Oxygen Analyzer. This should happen within 3-5 minutes.
- 2) When the two analyzers read within +/- 1%, make any final adjustments to the Membrane System input pressure necessary to obtain the exact Nitrox %O₂ desired as indicated on the Fill Oxygen Analyzer.
- 3) The system is now ready to pump Nitrox.



Fill Oxygen Analyzer

15.4 Pumping Nitrox

 **Warning**

The use of enriched air Nitrox does not eliminate the risk of decompression sickness (DCS) in diving. Decompression sickness can lead to permanent disability or death.

 **Warning**

The Permeate O₂ Analyzer supplies oxygen readings that can vary +/- 2% O₂ due to heat, humidity, and pressure changes in the Nitrox flow and should only be used for rough estimates of %O₂. The Fill O₂ Analyzer supplies more accurate readings, within +/- 1% O₂. For Scuba cylinder fills, the user must always verify the fill with a third independent O₂ analyzer.

 **Warning**

Do not use this system to produce Nitrox mixtures containing more than 40% oxygen. Pumping Nitrox mixtures with higher concentrations of oxygen may lead to fires or explosions, which can cause serious personal injury or death.

 **Warning**

Do not pump Nitrox mixtures at pressures above the HP Compressor rating, and never above 3600 P.S.I. (250 bar). The system is not rated for pressures above 3600 P.S.I. (250 bar). Higher pressures may lead to explosions which may cause serious personal injury or death.

 **Notice**

No oxygen cleaning of standard cylinders or plumbing is mandatory when using the Nitrox System to produce Nitrox containing a maximum of 40% oxygen. When filling oxygen clean cylinders, hyper-purification of the Nitrox is required using an optional Oxygen Compatible Air purification system available from Nuair.

 **Danger**

This Nitrox System does not produce Nitrox mixtures acceptable for 100% oxygen service.

 **Danger**

Never fill a cylinder that is marked, "For Oxygen Service," with Nitrox that has been produced by anything other than 100% oxygen clean system. Filling an oxygen clean cylinder with breathing gas containing hydrocarbons can lead to explosions if the cylinder is subsequently filled with gas mixtures containing gas mixtures containing greater than 40% oxygen.

 **Warning**

Only provide Scuba cylinder Nitrox fills to customers who have proof of Nitrox training and certification. Improper use of Nitrox can be fatal.

 **Danger**

This system is not cleaned for oxygen service and not all components are compatible with gas mixtures containing greater than 40% oxygen. Pumping gas mixtures containing greater than 40% oxygen will lead to explosions which may cause severe personal injury or death.

⚠ Warning

Each Scuba cylinder belonging to a customer must be analyzed by that customer at the Nitrox filling facility, using an oxygen analyzer independent of those used with the Nitrox System. An employee must witness that the customer has properly analyzed the gas in each cylinder, noted the maximum operating depth for that mixture, and signed and dated the fill log. The time of day must also be included with the date, since some customers may fill the same cylinder more than once a day.

Pump Nitrox as follows:

- 1) When filling a Scuba cylinder, follow all industry standards. Do not exceed rated pressure of cylinder, and do not exceed 3600 P.S.I. (250 bar) under any condition.
- 2) With fill whip bleed valve open and Nitrox flowing, verify that Fill Oxygen Analyzer %O₂ reading equals the desired Nitrox %O₂.
- 3) Close bleed valve, open cylinder valve, and fill cylinder. Monitor system for proper operation:
 - a) Monitor Oxygen Analyzers and recalibrate as required
 - b) Listen for proper operation of automatic condensate drains every 10-15 minutes.
 - c) Monitor all system gauges as shown in the table below.

⚠ Notice

The Oxygen Analyzers may require re-calibration after 10-20 minutes of operation due to humidity and temperature change effects on the Sensor. To recalibrate, turn off the LP Feed Air Switch and follow calibration instructions.

⚠ Notice

When the HP Compressor auto drain engages and dumps condensate, the Fill Oxygen Analyzer reading will decrease momentarily due to the pressure drop in the system. It will return to its previous reading within seconds after the auto drain sequence stops.

GAUGE	RECOMMENDED SETTING
Compressor Gauges	According to manufacturers recommendations
Heater Temperature	105-120° F (40-49° C)
Cabinet Temperature	Less than 100° F (38° C)
Volume Tank Pressure	165-175 PSI (11-12 bar)
Membrane Feed Air Pressure	80 - 175psi (5.5-12 bar) depending on Nitrox O ₂ %
Fill Oxygen Analyzer	Showing the proper reading for intended fill
Nitrox Storage Pressure	<u>DO NOT</u> exceed rating of tank or 3600 P.S.I (250 bar)

- 4) After filling is complete, close cylinder valve, vent the bleed valve, and remove the cylinder.
- 5) Test the Nitrox %O₂ in the cylinder using an independent Oxygen Analyzer such as the Nuvair O₂ Quickstick™. Calibrate analyzer before use in accordance with manufacturer's instructions.
- 6) Repeat steps 1-5 until you have filled all Scuba cylinders.
- 7) Mark each tank with fill date, %O₂, fill pressure, and MOD (Maximum Operating Depth).



Use Independent Oxygen Analyzer for Verification

- 8) Log every Nitrox fill to document the following information:
- ◆ Fill date and time of day
 - ◆ Tank Number
 - ◆ Supplier's check of oxygen content (%O₂) plus signature and date
 - ◆ User's check of oxygen content (%O₂) plus signature and date
 - ◆ Fill Pressure
 - ◆ MOD (Maximum Operating Depth) in user's handwriting
 - ◆ Nitrox certifying agency and card number
- 9) When filling a HP Nitrox storage tank, verify that Fill Oxygen Analyzer %O₂ reading equals the desired Nitrox %O₂. Open applicable line valves and tank valve, and fill with Nitrox. Do not exceed rated pressure of cylinder, and do not exceed 3600 P.S.I. (250 bar) under any condition. After filling is complete, close all valves and allow Nitrox System to shut down.

15.5 Pumping Air

To use the System to pump air, simply move the On/Off LP Feed Air Valve to the Off position. No Nitrox will be supplied to the compressor, and it will pump air only. Both the Inline Oxygen Analyzer and Fill Oxygen Analyzer should read 20.9% O₂ when the compressor is pumping air.



Notice

Always use Oxygen Analyzers to monitor oxygen content of any gas flowing through the System. Both air and Nitrox are subject to variations in oxygen content.

15.6 Shutting Down

- 1) Shut off the Membrane System by turning the regulator adjustment knob CCW to reduce input pressure to minimum setting and then closing the On/Off Flow Valve.
- 2) Manually drain all filter, compressor, and Volume Tank condensate drains.
- 3) Turn off LP compressor On/Off Switch. The compressor will go into shut down mode.
- 4) Turn off Nitrox Compressor when it has returned to pumping air, as determined by a Fill Oxygen Analyzer reading close to 20.9% O₂.

16. Nitrox Operation Notes

16.1 Correlation of Input Pressure to Oxygen Content

After the 10 hour break-in period for your Nitrox System, you will notice that specific Nitrox %O₂'s always match specific input pressures once the System has warmed up. These pressures will be repeatable. If you find that the Fill Oxygen Analyzer reads 36% O₂ when the input pressure is at 125 P.S.I. (9 bar), record this pressure or make a mark on the input pressure gauge indicating the %O₂. Do this for each %O₂ that you normally make, making sure System has warmed up first. The next time Nitrox with 36% O₂ is needed, adjust the regulator to 125 P.S.I. (9 bar) and wait for the Oxygen Analyzer reading to stabilize. You will find the analyzer reading to be very close to 36% O₂, requiring only minor adjustments of the regulator to achieve the exact desired %O₂.

Notice

Use the Fill Oxygen Analyzer to verify the Nitrox oxygen percentage prior to pumping. When using the feed air pressure reading to obtain specific oxygen percentage, minor adjustments of the feed air pressure regulator may be required to obtain the exact percentage desired.

16.2 Hot Fills

While in the process of filling HP Nitrox Storage Tanks, you may have a need to supply a walk-in customer with a Scuba Cylinder fill of a different Nitrox mix. You can change mixes as follows:

- 1) With the Nitrox System and HP compressor operating, isolate the HP Nitrox Storage Tanks from the HP compressor by closing appropriate valves.
- 2) Record the Membrane System input pressure reading
- 3) Slightly open fill whip valve on the HP compressor, and adjust so the running compressor maintains 1500-2000 P.S.I. (100-140 bar) outlet pressure.
- 4) Adjust the input regulator to the pressure corresponding to the desired Nitrox %O₂ for the Scuba Cylinder fill.
- 5) Allow the Fill Oxygen Analyzer reading to stabilize, make any minor adjustments necessary to achieve the desired %O₂, and then fill cylinder in normal manner.
- 6) When finished return regulator to previous setting, and allow the Fill Oxygen Analyzer reading to stabilize. Make any minor adjustments necessary to achieve the desired %O₂, and then resume filling Storage Tanks.

17 Maintenance

The following list of daily and routine maintenance items is intended as a guide. Refer to LP and HP compressor manuals for complete maintenance requirements.

17.1 Daily Maintenance

Caution

Be sure to check Compressor Lubricant levels prior to each day of operation. Failure to ensure the proper lubricant level will lead to system damage.

- 1) Check lubricant levels of both LP and HP compressors and add proper lubricants as required. See Section 17.3 and compressor manuals for details.
- 2) Check HP compressor Filtration for condensate and proper operation of condensate drains. Refer to HP compressor manual for details.
- 3) Drain condensate from LP Volume Tank by opening drain valve and draining all moisture.
- 4) Check LP Air Filtration for condensate and proper operation of condensate drains.

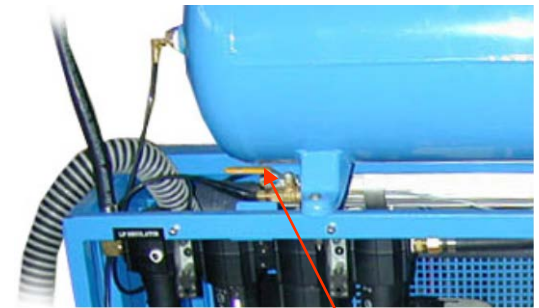

LP Volume Tank
Condensate Drain Valve

17.2 Routine Maintenance

Warning

Use only the specified Nuair Lubricants in this system. The use of incompatible lubricants presents a risk of fire and/or explosion, and may result in system damage. This can lead to severe personal injury and death.

Warning

Be sure that all pressure has been relieved from the system prior to opening any filtration canister. Failure to vent pressure from the system prior to opening the canister can lead to serious personal injury or death.

Caution

If system is located in an area where there is high humidity and high heat, the life of all Filtration Elements may be as little as 35% of rated operating capacity. Check the Compressor manual and Appendix for details on Filter Element Life Factors.

- 1) LP Air Compressor Lubricant: Change compressor lubricant every 200 hours. Only use lubricants rated for use with Nitrox, such as Nuair 455™. Never mix compressor lubricants. See Section 17.3 and LP Air Compressor manual for details.
- 2) LP Air Filtration Inspection: On a weekly basis, inspect each Filter Bowl for the presence of moisture and each Element for any unusual degradation or wetness. See Section 17.4 for details.

⚠ Caution

Special attention needs to be given to the arrangement of the four LP Air Filtration Elements and Bowls. Properly reinstall each Element and Bowl to the correct Housing. Improper sequence can cause damage to downstream components.

- 3) LP Air Filtration Elements: Change LP Filter Elements every 100 hours to maintain CGA Grade D air standards. Visual liquid level and service life indicators assist with monitoring replacement intervals. See Section 17.4 for details. If the Nitrox System is operated in high humidity and/or high temperature, Filter Elements must be changed more often. See Appendix for details on Filter Element Life Factors.
- 4) Semi-Permeable Membrane: No maintenance required. Service life exceeds 20 years if LP Air Filtration is properly serviced to maintain Grade D standards.
- 5) Membrane System Air Intake Filter: Inspect filter element every 3 months for visible particles. Change every 12 months or sooner if particles are visible.
- 6) Oxygen Analyzers: Replace Oxygen Sensor and Battery as required. See manual included with Nitrox System.



Service Indicator Changes from Green to Red as Filter Ages. Do Not Use When Red.

Liquid Level Indicator Shows if Auto Drain is Working Correctly.

⚠ Danger

Do not swallow (ingest) either the electrolyte from the Oxygen Sensor or the Sensor itself. The Potassium Hydroxide chemical contained in the Sensor can cause severe injury or death. If electrolyte or the Sensor is swallowed, seek medical attention immediately.

⚠ Danger

If after handling the Oxygen Analyzer or Sensor, you find that your fingers or other parts of your body feel “slippery” or the skin or eyes sting, immediately flush affected area with clean, fresh water for at least 15 minutes. The stinging or slippery sensation is an indication of a leaking Sensor. The Potassium Hydroxide chemical contained in the Sensor can cause severe injury or death. Seek immediate medical attention if eye contact is made or skin stinging persists.

The following items are not integral parts of the Nitrox System, but proper maintenance is required to assure optimum performance.

- 1) Nitrox Compressor Lubricant: Change Nitrox Compressor Lubricant every 100 hours of operation in accordance with manufacturer’s guidelines. Only use lubricants rated for use with Nitrox, such as Nuair 455™. Never mix compressor lubricants. Refer to Nitrox compressor manual for details.
- 2) Breathing Air Filters: Change Nitrox Compressor Filter Elements in accordance with manufacturer’s guidelines to maintain CGA Grade D or E breathing air standards.
- 3) Air/Nitrox Quality Analysis: Take breathing air/Nitrox samples quarterly for analysis to assure compliance with CGA Grade D or E breathing air standards.

17.3 Compressor Lubricant

The LP Air Compressor in your Nitrox System comes standard with Nuvair 455™ Synthetic Food Grade Compressor Lubricant. Check lubricant level at Sight Gauge and add lubricant as required through Fill Plug. Lubricant is removed through Drain Plug. See LP Air Compressor manual for details on servicing lubricant.

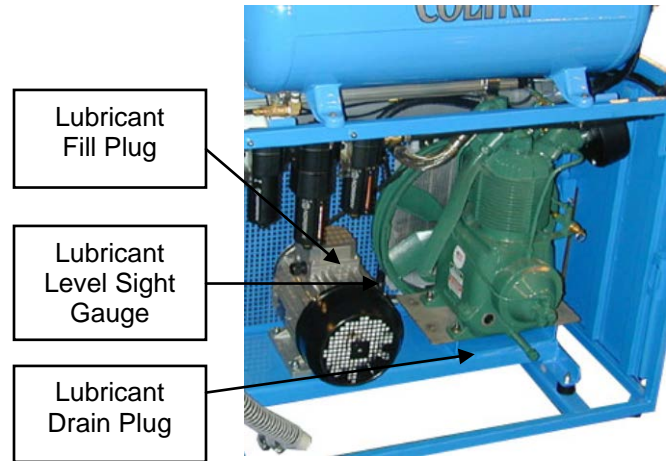

17.4 LP Air Filtration

Caution

Special attention needs to be given to the arrangement of the four LP Feed Air Filtration Elements and Bowls. Properly reinstall each Element and Bowl to the correct Housing. Improper sequence can cause damage to downstream components

LP Filtration

The use of Grade D or better supply air is critical to prevent the passing of any residual oil vapor into the Membrane System. Three stages of Hankison LP filtration are used to produce Grade D air:

- 1) Particle Removal to 1 micron
- 2) Coalescing & Water/Oil Vapor Removal to 0.01 micron
- 3) Oil Vapor Removal to 0.003 PPM

Filtration Inspection

Open each Filter and inspect as follows:

1. Inspect Bowl for the presence of moisture. A high level of moisture build-up in the HF7 or HF5 Filter indicates improper operation of auto-drain floats. Any evidence of moisture in the HF1 Filter indicates the air is not cooling properly and moisture is not properly being removed. Excess moisture will prevent the final filter from operating properly.
2. Inspect Elements for any unusual degradation or wetness. Element degradation can indicate more serious problems. Contact Nuvair for assistance.

Element LP™ Nitrox System

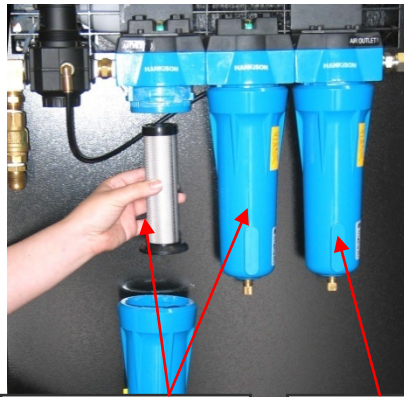

HF7 & HF5
Filters with Auto-
Drain Floats &
DP Indicators.

HF1 Filter with
Manual Drain –
Should not
Contain Moisture

Changing Filtration Elements

Change the LP Filter Elements every 100 hours or once per year*. If the Nitrox System is operated in high humidity and/or high temperature, Filter Elements must be changed more often. See Appendix for details on Filter Element Life Factors. Visual DP indicators on the HF7 and HF5 filters assist with monitoring replacement intervals.

- 1) Push up on the Bowl, rotate CCW, and lower to remove.
- 2) Gently rotate Filter Element and pull down off mounting post.
- 3) Replace Element and reassemble in reverse order.

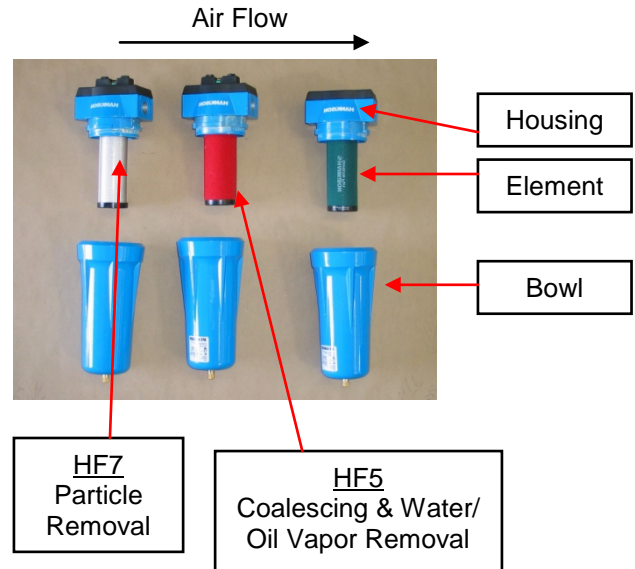

**DP Indicator
Changes from
Green to Red.
Yellow indicates
filter needs to be
replaced.
Do Not Use
When Red.**



⚠ Notice

The interior of the Filter Bowls can be cleaned with a diluted solution of Simple Green™ and flushed thoroughly with clean water. This will assist to prolong the life of the element, bowl, and auto drain.

17.5 Spare Parts List

See LP Air Compressor manual for LP Compressor parts list. Other Nitrox System components and related items are listed below.

Nitrox System Components	Type	Part Number
Compressor Lubricant, Food Grade, Nitrox Compatible	Nuvair 455, 1 Gal (Other Sizes Available)	9406
7 CFM Element		
LP Filtration Element	Hankinson HF7-16	E7-16
	Hankinson HF5-16	E5-16
	Hankinson HF1-16	E1-16
9 CFM Element		
LP Filtration Element	Hankinson HF7-20	E7-20
	Hankinson HF5-20	E5-20
	Hankinson HF1-20	E1-20
Heater Assembly	1200 Watt, 28" Length	H1200
Heater Thermostat Control	110V/220V	A419
Heater Pressure Switch		3100-052
Membrane	230 Series	NUV230
Air Intake Filter Element		14
Oxygen Analyzer	Pro O2	9460
	Pro O2 Remote	9462
Oxygen Sensor	Pro O2	9505
	Pro O2 Remote	9506
Related Equipment Components		
Air/Nitrox Quality Analysis Kit	Specify: (1) CGA Grade Required	
	(2) Single Use or Program Use	

Appendix

Supply and Breathing Air Specifications

All supply and breathing air must meet the following requirements of CGA G-7.1-1997. Supply air delivered to the Membrane System must be purified to meet Grade D or E quality, and periodic air quality testing to assure compliance is recommended. All breathing air for diving produced by the downstream compressor must be purified to meet Grade E quality, and periodic air quality testing to assure compliance is mandatory.

Item	Grade D	Grade E
Oxygen	19.5-23.5%	20-22%
Carbon Dioxide (maximum)	1000 PPM	1000 PPM
Carbon Monoxide (maximum)	10 PPM	10 PPM
Hydrocarbons (maximum)	Not specified	25 PPM
Water Vapor (maximum)	Not specified	Not specified
Dew Point (maximum) (1)	Not specified	Not specified
Oil & Particles (maximum) (2)	5 mg/m3	5 mg/m3
Odor	None	None

Notes: (1) Dew Point of supply air must be >10°F (6°C) colder than coldest ambient air expected
 (2) Supply air delivered to the Membrane System must contain <0.003 PPM Oil Vapor

All breathing Nitrox produced for diving must be purified to meet these same requirements, except for oxygen content. Nitrox oxygen content must measure within +/- 1% O₂ of the specified value of the mixture using a properly calibrated Oxygen Analyzer (i.e. Nitrox produced with a target content of 32% O₂ must measure in the range of 31-33% O₂). Periodic air quality testing to assure compliance is mandatory.

Filter Element Life Factors

Breathing air filter element life is typically rated by manufacturer based on an air temperature of 80°F at the filter inlet. Under normal operation this temperature is 12°F (5°C) warmer than the ambient air, resulting in an equivalent ambient temperature rating at 68°F (20°C).

To determine element life at a different ambient temperature, multiply the rated life by the life factor listed below:

Filter Temperature	Ambient Temperature	Filter Element Life Factor
53°F (12°C)	41°F (5°C)	2.6 x Life
62°F (17°C)	50°F (10°C)	1.8 x Life
71°F (23°C)	59°F (16°C)	1.35 x Life
80°F (27°C)	68°F (20°C)	1 x Life
89°F (32°C)	77°F (25°C)	0.8 x Life
96°F (36°C)	84°F (29°C)	0.55 x Life
105°F (41°C)	93°F (34°C)	0.45 x Life
114°F (46°C)	102°F (39°C)	0.35 x Life

Material Safety Data Sheets

Nuvair™ 455 Premium Synthetic Food Grade Air/Nitrox Compressor Lubricant

Effective Date: 03/19/2010

I. Product Identification:

Trade Name: Nuvair 455

Chemical Name: Polyalphaolefin

Chemical Family: Synthetic Hydrocarbon / Esters

II. Components & Hazard Statement:

This product is non-hazardous. The product contains no known carcinogens. No special warning labels are required under OSHA CFR 1910.1200. This product complies with FDA 21 CFR 178.3570 regarding lubricants for incidental food contact.

III. Physical Data:

Viscosity:..... 100 cst. @40°C

Specific Gravity (Water = 1.0): 0.85

Boiling Point:N.A.

Vapor Pressure: Negligible

Appearance & Odor: Clear – with little odor

Solubility in Water:Negligible

IV. Fire & Explosion Hazard Data:

Flash point: 464°F/240°C

Autoignition Temperature: Not Established

Flammability Limits: Not Established

Extinguishing Media:Dry Chemical; CO2 Foam; Water Spray

Special Fire Fighting Procedure: Burning may produce irritating/noxious fumes. Firefighters should use NIOSH/MNSA approved self-contained breathing apparatus. Use water to cool fire-exposed containers to prevent pressure build-up.

V. Reactivity Data:

Stability: This product is stable and will not react with water.

Materials to Avoid: Avoid strong oxidizers

Hazardous Decomposition Products: Carbon monoxide, Carbon dioxide

VI. Health Information:

Eye Contact: Flush eyes with water for 15 minutes. Call a physician if irritation develops.

Skin Contact: Wash skin with soap and water.

Inhalation:Remove to fresh air.

Ingestion:First aid not normally required. If uncomfortable, call physician.

VII. Health Hazard Data:

Exposure Limit:Not Applicable

Effects of Overexposure: Low oral and dermal toxicity. Prolonged or repeated exposure may cause irritation, nausea, and vomiting.

VIII. Employee Protection:

For general personal hygiene, wash hands thoroughly after handling material. Avoid contact with skin and eyes. Chemical impervious gloves are not required, but may be recommended for prolonged exposure. Use in a well ventilated area.

IX. Storage, Spill, & Disposal Procedures:

Storage: Store in clean, dry area.

Spills: Use absorbent materials to soak up fluid.

Disposal: Incinerate this product and all associated wastes in a licensed facility in accordance with Federal, state, and local regulations.

X. Hazard Rating Information:

NFPA

Health: 0

Flammability: 1

Reactivity: 0

Personal Protection: B

This information contained herein is based on the data available to us and is believed to be true and accurate. Nuvair makes no warranty, expressed or implied, regarding the accuracy of this data or the results to be obtained from the use thereof. Nuvair assumes no responsibility for injury from the use of this product.

Element LP™ Nitrox System

Nuvair™ 751 Premium Synthetic Diester Based Air/Nitrox Compressor Lubricant

Effective Date: 3/10/2010 Supercedes:

I. Product Identification:

Trade Name: Nuvair 751

Chemical Name: Diester/organic compound blend

Chemical Family: Diester

II. Components & Hazard Statement:

This product is non-hazardous. The product contains no known carcinogens. No special warning labels are required under OSHA CFR 1910.1200. SARA TITLE 111 SECTION 313 (40 CFR PART 372): This product is not regulated under Section 313 and 40 CFR Part 372.

III. Physical Data:

Viscosity: 146 cst. @40°C
Specific Gravity (Water = 1.0): 0.94
Boiling Point: Not determined
Vapor Pressure: Negligible
Appearance & Odor: Amber – Mild odor
Solubility in Water: Negligible
Other Data: Non-toxic USDA H-2 approved

IV. Fire & Explosion Hazard Data:

Flash point: 520°F / 271°C
Autoignition Temperature: 765°F ASTM D-2155
Flammability Limits: Not Established
Extinguishing Media: Dry Chemical; CO2 Foam; Water Spray
Special Fire Fighting Procedure: Burning may produce irritating/noxious fumes. Firefighters should use NIOSH/MNSA approved self-contained breathing apparatus. Use water to cool fire-exposed containers to prevent pressure build-up.

V. Reactivity Data:

Stability: This product is stable and will not react with water.
Materials to Avoid: Avoid strong oxidizers
Hazardous Decomposition Products: Carbon monoxide, Carbon dioxide

VI. Health Information:

Eye Contact: Flush eyes with water for 15 minutes. Call a physician if irritation develops.
Skin Contact: Wash skin with soap and water.
Inhalation: Remove to fresh air.
Ingestion: First aid not normally required. If uncomfortable, call physician.

VII. Health Hazard Data:

Exposure Limit: Not Applicable
Effects of Overexposure: Low oral and dermal toxicity. Prolonged or repeated exposure may cause irritation, nausea, and vomiting.

VIII. Employee Protection:

For general personal hygiene, wash hands thoroughly after handling material. Avoid contact with skin and eyes. Chemical impervious gloves are not required, but may be recommended for prolonged exposure. Use in a well ventilated area.

IX. Storage, Spill, & Disposal Procedures:

Storage: Store in clean, dry area.
Spills: Use absorbent materials to soak up fluid.
Disposal: Incinerate this product and all associated wastes in a licensed facility in accordance with Federal, state, and local regulations.

X. Hazard Rating Information:

NFPA

Health: 0

Flammability: 1

Reactivity: 0

Personal Protection: B

This information contained herein is based on the data available to us and is believed to be true and accurate. Nuvair makes no warranty, expressed or implied, regarding the accuracy of this data or the results to be obtained from the use thereof. Nuvair assumes no responsibility for injury from the use of this product.

OWNER'S WARRANTY RESPONSIBILITIES

Failure of the owner to prevent equipment damage by complying with the procedures outlined below and in the Operation Manual will void the Nitrox System warranty.

Installation:

- All set up requirements and procedures provided in the Nitrox System Operation Manual must be followed in their entirety including supply air cleanliness, compressor preparation, and installation of the Nitrox System.
- Supply air to the Membrane must be properly filtered to CGA Grade D air quality or better to prevent damage to the Membrane. Air quality testing of the supply air should be performed periodically and documented to assure compliance.
- If there is any doubt regarding the suitability of a HP or LP compressor for compressing Nitrox, contact Nuair or the compressor manufacturer before you connect your Nitrox System.
- If an existing HP or LP compressor is to be used for compressing Nitrox, all traces of the old lubricant must be removed and replaced with a Nitrox Compressor Lubricant approved by Nuair.
- Electrical wiring and connections should be made by a qualified electrician in accordance with all national and local electrical codes.
- Do not change the temperature setting on the Heater Thermostat Control. Changes in temperature settings may cause Membrane damage.
- To prevent compressor damage, only use the compressor Intake Hose provided. If a longer hose is required, contact Nuair for assistance.
- Compressors must be provided adequate ventilation to operate properly and prevent heat damage. This requires an ambient temperature below 100 °F (40 °C), sufficient clearance from adjacent walls, and proper rotation direction.

Operation:

- Do not use the Nitrox System to supply a HP or LP compressor with Nitrox mixtures containing more than 40% oxygen. Compressing higher concentrations of oxygen may cause severe compressor damage.
- Do not pump Nitrox mixtures at pressures above the compressor manufacturer's rating, and never above 3600 P.S.I. (250 bar). Compressing Nitrox at higher pressures may cause severe HP compressor damage.
- To prevent Membrane damage, drain all low pressure filter and volume tank condensate on a daily basis.
- If you become aware of an operational fault, stop using the equipment immediately and contact Nuair for assistance.

Warning

Do not use this system to produce Nitrox mixtures containing more than 40% oxygen. Pumping Nitrox mixtures with higher concentrations of oxygen may lead to fires or explosions, which can cause serious personal injury or death.

Maintenance:

- Change low pressure filter elements on a schedule determined by filter capacity and ambient temperature and humidity. Contact Nuair if you need assistance establishing a schedule for your equipment and location.
- Replace Membrane System Air Intake Filter on a regular basis to prevent flow obstruction.
- Keep all nuts, bolts, fittings, connectors, and clamps tight.
- Keep service record books showing that regular maintenance work has been carried out. If a warranty claim becomes necessary, it will aid in demonstrating that damage has not been caused by insufficient maintenance. Proof of maintenance may be required prior to determining the validity of a warranty request.

NUVAIR NITROX SYSTEM WARRANTY

NUVAIR extends a limited warranty, which warrants the Nitrox System to be free from defects in materials and workmanship under normal use and service for a limited period. The specific Membrane Component of the Nitrox System is warranted according to the pro-rated terms as set forth below. All other Original Equipment Manufacturer (OEM) components used in the system are warranted only to the extent of the OEM's warranty to NUVAIR. NUVAIR makes no warranty with respect to these OEM components, and only warrants the workmanship that NUVAIR has employed in the installation or use of any OEM component. This warranty is not transferable.

NUVAIR will, at its discretion and according to the terms as set forth within, replace or repair any materials which fail under normal use and service and do not exhibit any signs of improper maintenance, misuse, accident, alteration, weather damage, tampering, or use for any other than the intended purpose. Determination of failure is the responsibility of NUVAIR, which will work together with the customer to adequately address warranty issues. When any materials are repaired or replaced during the warranty period, they are warranted only for the remainder of the original warranty period. This warranty shall be void and NUVAIR shall have no responsibility to repair or replace damaged materials resulting directly or indirectly from the use of repair or replacement parts not approved by NUVAIR.

Pro-Rated Terms:

NUVAIR warrants the Membrane Component of the Nitrox System to be free from defects in material and workmanship for a period of thirty-six (36) months from date of installation or forty-two (42) months from date of shipment by NUVAIR, whichever may occur first. The warranty covers parts only and is prorated as follows:

- First Year Repair or replacement free of charge
- Second Year Warranty allowance of 70% of the current Membrane Component list price
- Third Year Warranty allowance of 40% of the current Membrane Component list price

A warranty registration card, supplied with system documentation, must be filled out and submitted to NUVAIR for the warranty to be in full effect. If the warranty registration card is not received within thirty (30) days of installation, the thirty-six (36) month warranty will begin with the date of shipment from NUVAIR. For warranty service to be considered, customer's account must be current or paid in full.

Maintenance Items:

Any materials which are consumed, or otherwise rendered not warrantable due to processes applied to them, are considered expendable and are not covered under the terms of this policy. This includes maintenance and consumable items listed as part of a suggested maintenance program included with system documentation.

Return Policy:

Application for warranty service can be made by contacting NUVAIR during regular business hours and requesting a Return Material Authorization number. Materials that are found to be defective must be shipped, freight pre-paid, to the NUVAIR office in Oxnard, California. Upon inspection and determination of failure, NUVAIR shall exercise its options under the terms of this policy. Warranty serviced materials will be returned to the customer via NUVAIR's preferred shipping method, at NUVAIR's expense. Any expedited return shipping arrangements to be made at customer's expense must be specified in advance.

Limitation of Warranty and Liability:

Repair, replacement or refund in the manner and within the time provided shall constitute NUVAIR'S sole liability and the Purchaser's exclusive remedy resulting from any nonconformity or defect. NUVAIR shall not in any event be liable for any damages, whether based on contract, warranty, negligence, strict liability or otherwise, including without limitation any consequential, incidental or special damages, arising with respect to the equipment or its failure to operate, even if NUVAIR has been advised of the possibility thereof. NUVAIR makes no other warranty or representation of any kind, except that of title, and all other warranties, express or implied, including warranties of merchantability and fitness for a particular purpose, are hereby expressly disclaimed. No salesman or other representative of NUVAIR has authority to make any warranties.

Notes:



Nuvair
Phone 1-805-815-4044
Fax 1-805-486-0900
1600 Beacon Place
Oxnard, CA 93033 USA
Email : info@nuvair.com
Web : www.nuvair.com
rev.02.16