



User Manual

**Pro H<sub>2</sub>O Alarm**  
**with Lithium Battery**

Moisture Analyzer  
Rev. 08.22

If you have any questions on this equipment please contact Technical Support at:

Nuvair  
1600 Beacon Place  
Oxnard, CA 93033

Phone: +1 805 815 4044  
Fax: +1 805 486 0900  
Email: [info@nuvair.com](mailto:info@nuvair.com)

Hours: Monday through Friday  
8:00 AM to 5:00 PM PST USA

## **Warning**

**This User Manual contains important safety information and should always be available to those personnel operating this equipment. Read, understand and retain all instructions before operating this equipment to prevent injury or equipment damage.**

Every effort was made to ensure the accuracy of the information contained within this manual; however, we retain the right to modify its contents without notice. If you have problems or questions after reading the manual, stop and call for information.

## **Warning**

**Never expose gas sensors to pressure or you may cause damage and/or false readings. Damaged sensors will not provide accurate gas analysis. Most gas analyzers can be used to analyze a regulated gas sample flow, the contents of a gas cylinder, or the flow from a regulator. The flow rate of gas must equal 1-5 L/min. To produce this flow, a Flow Restrictor and Regulator may be required. A faulty Flow Restrictor can lead to a false analyzer reading. Flow Restrictors should be regularly tested with a Flow Meter. Inaccurate gas analysis can lead to serious personal injury or death.**

## Table of Contents

<b>1.0 Introduction.....</b>	<b>1</b>
<b>2.0 System Description .....</b>	<b>2</b>
<b>2.1 Controls .....</b>	<b>3</b>
<b>2.2 Display .....</b>	<b>3</b>
<b>2.3 Alarm.....</b>	<b>3</b>
<b>2.4 Sensor.....</b>	<b>3</b>
<b>2.5 Batteries .....</b>	<b>3</b>
<b>3.0 Calibration .....</b>	<b>4</b>
<b>4.0 Operation.....</b>	<b>4</b>
<b>4.1 Programming Procedures .....</b>	<b>5</b>
<b>4.2 Alarm Setting (AL 1 &amp; AI 2) .....</b>	<b>6</b>
<b>4.3 Full Scale Value Setting (FSC) .....</b>	<b>7</b>
<b>4.4 Ambient Pressure Value (PrE) .....</b>	<b>7</b>
<b>5.0 Calibration in 0% humidity dry gas .....</b>	<b>7</b>
<b>6.0 Threshold Alarms .....</b>	<b>8</b>
<b>7.0 Powering Off .....</b>	<b>8</b>
<b>8.0 Factory Reset .....</b>	<b>8</b>
<b>9.0 Maintenance.....</b>	<b>9</b>
<b>9.1. Analyzer Care .....</b>	<b>9</b>
<b>9.2 Sensor Cleaning.....</b>	<b>9</b>
<b>10.0 Troubleshooting .....</b>	<b>10</b>
<b>11.0 Relay Output Schematics .....</b>	<b>10</b>
<b>12.0 Analyzer Specifications.....</b>	<b>11</b>
<b>Nuvair Pro H<sub>2</sub>O Warranty .....</b>	<b>12</b>

## 1.0 Introduction

This manual will assist you in the proper set-up, operation and maintenance of the Pro H<sub>2</sub>O Moisture Analyzer. Be sure to read the entire manual.

Throughout this manual we will use certain words to call your attention to conditions, practices or techniques that may directly affect your safety. Pay particular attention to information introduced by the following signal words:

### **Danger**

Indicates an imminently hazardous situation, which if not avoided, will result in serious personal injury or death.

### **Warning**

Indicates a potentially hazardous situation, which if not avoided, could result in serious personal injury or death.

### **Caution**

Indicates a potentially hazardous situation, which if not avoided, may result in minor or moderate injury. It may also be used to alert against unsafe practices.

### **Notice**

Notifies people of installation, operation or maintenance information which is important but not hazard-related.

#### Warnings Graphics Defined:



Gas Inhalation



Skin damage

## 2.0 System Description

The Pro H<sub>2</sub>O Moisture Analyzer measures water (H<sub>2</sub>O) levels in gases in the range of 0 to 500 parts per million (ppm). It can be used to measure the water content in gas mixes that will increase with humidity and moisture saturation of filters. The Analyzer is designed to verify H<sub>2</sub>O concentration in stored gas cylinders as well as to monitor continuous gas flow from a compressor.



### **Danger**

**As soon as the analyzer alarm is tripped, shut down your compressor system and replace all of your filter cartridges in the compressor system.**

The Analyzer is battery powered and includes a remote Sensor with audible alarm, Digital Display and controls that are environmentally sealed.

Use of this Analyzer in a hyperbaric chamber will void the owner's warranty.

The Analyzer is ready for use after calibration with an appropriate certified calibration gas.



### **Warning**

This analyzer is designed for use at atmospheric pressures only. It is not designed for exposures in a hyperbaric chamber. Use of this analyzer in a hyperbaric chamber will result in incorrect readings and may damage the unit.

### **Warning**

Although the Analyzer is a rugged instrument, careless handling or abuse may result in damage to the Analyzer, causing an inaccurate gas analysis. Inaccurate gas analysis can lead to serious personal injury or death.

### **Notice**

Extreme H<sub>2</sub>O exposure levels directed at the Analyzer sensor may damage the sensor.

### 2.1 Controls

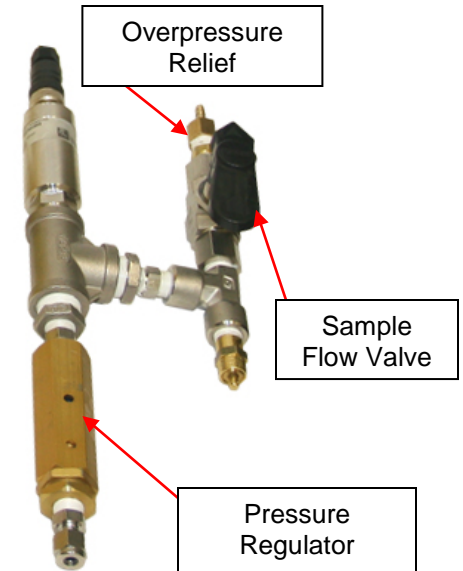
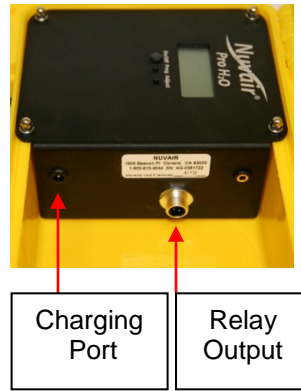
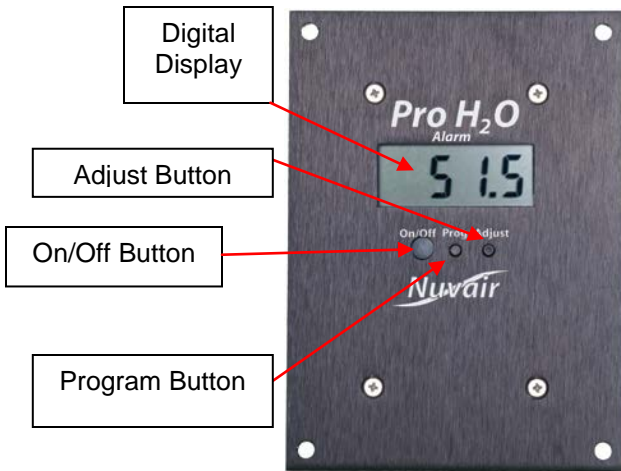

### 2.2 Display



Moisture Reading  
0 – 500 ppm  
In 1 ppm  
increments

Moisture Reading  
0 – 100%  
In .1 % increments



### 2.3 Alarm

The Analyzer includes an audible alarm that is activated when the Sensor reaches user programmed level. The alarm will not clear until the concentration of Moisture drops below user programmed level.



**⚠ Danger**

**As soon as the analyzer alarm is tripped, shut down your compressor system and replace all of your filter cartridges in the compressor system.**

### 2.4 Sensor

The Analyzer uses a Capacitive H<sub>2</sub>O Sensor to measure moisture content in gases and has a life expectancy of 60 months plus depending on usage. The Sensor is designed for use at atmospheric pressure (0 psi). The gas mixture to be analyzed must be regulated accordingly, and any potential for pressure or vacuum must be avoided.

### 2.5 Batteries

One 9-volt battery provides power. The battery is located inside the Analyzer and is user-replaceable. The battery should be removed any time the Analyzer will be stored without use for extended periods of time. Screen will blink alternately from “000” to “bAt” at start up when battery is low.

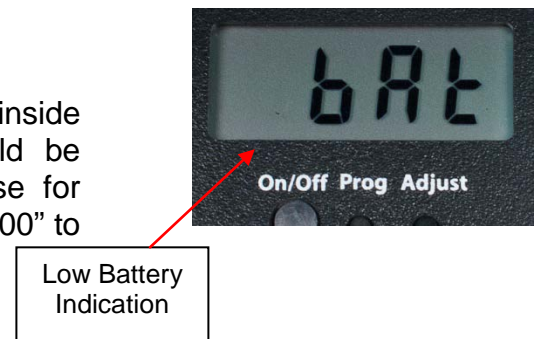

### 3.0 Calibration

#### Warning

Analyzer calibration must be verified on a daily basis. Improper calibration may result in an incorrect reading, delivering inaccurate levels of moisture being monitored.

#### Warning

Checking Calibration or use of the Analyzer with a low battery may result in inaccurate readings. Inaccurate gas analysis can lead to serious personal injury or death.

#### Notice

If the Analyzer has been subjected to a recent change in ambient temperature, allow it to stabilize for one hour before checking calibration.

An integrated auto-calibration procedure permits a measurement accuracy of <math>±36^{\circ}\text{F}</math> (<math>±2^{\circ}\text{C}</math>) Td. The recommended calibration interval is 2 years.

### 4.0 Operation

Prior to each Analyzer use:

- 1) To turn the unit on, hold the On/Off button until the display show "On". Monitor the display for low battery warning. Replace battery immediately if warning appears. Once fully cycled the screen should read "000".

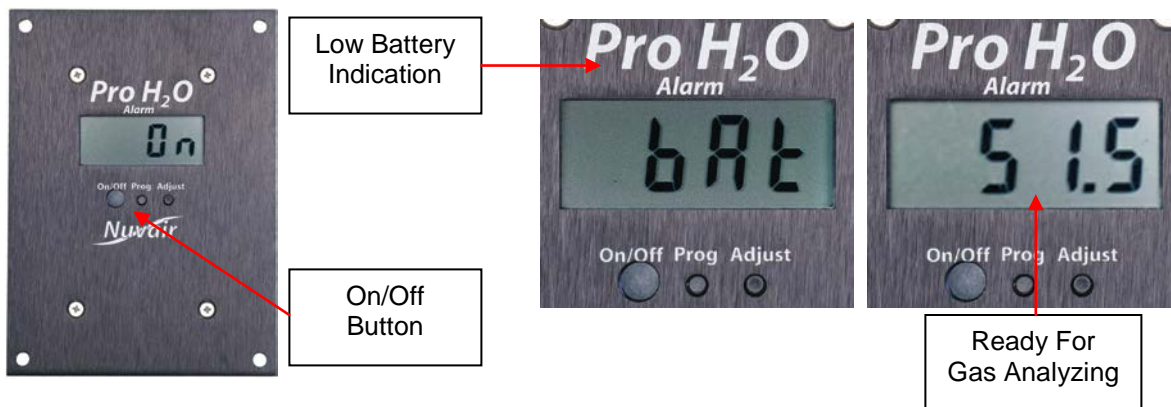

- 2) The display will cycle through a couple screens and finish with the current relative humidity percentage of moisture being sensed.
- 3) **At this time the Alarm function should be activated by holding the "On/Off" and "Prog" buttons until the display flashes ALN, then ON. The alarm function is active when a triangle is present in the upper left corner of the display.**
- 4) Cycle through the current alarm settings of the analyzer.
  - a. Hold down the "Prog" button for 2 seconds then use the "On/Off" button to cycle through the 1<sup>st</sup> Alarm Value, 2<sup>nd</sup> Alarm Value, Full Scale Value, and Pressure Value. The "End" screen will display for a couple seconds before going back to the current percentage of moisture.



- b. Adjust Alarm values at this time if needed see “**4.2 Programming**”
- 4) Pressing the Adjust key the Temperature value (°C) (TeM) is displayed.
- 4.1) Pressing again the ADJUST key PPM in volume (PPM) is displayed.
  - 4.2) Pressing again the ADJUST key Absolute humidity (gr/m<sup>3</sup>) (AbH) is displayed. The absolute humidity is the mass of water vapor in a particular volume of dry air
  - 4.3) Pressing again the ADJUST key Dew Point (°C) (td) is displayed.
  - 4.4) Pressing again the ADJUST key Mixing ratio (gr/Kg) (Mr) is displayed. The mixing ratio is the mass of water vapor in a particular mass of dry air.
  - 4.5) Pressing again the ADJUST key Volt output of the battery (Bat) is displayed.
  - 4.6) Pressing again the ADJUST key zero Offset value (OFS) is displayed. This value is 0 if the analyzer is not adjusted in dry gas. If the instrument was adjusted in 0% RH, OFS is the value of the relative humidity at the zeroing time. During the OFS visualization, pressing at the same time for three seconds ON/OFF and ADJUST key, the instrument will lose the 0 Adjustment, and the OFS value will go to 0.
  - 4.7) Pressing again the ADJUST key Relative humidity value is displayed. (Home Screen)
- 5) **Open the Sample Flow Valve after starting the compressor. Close the Sample Flow Valve before shutting the compressor down.**

### **Warning**

**Gas, even under moderate pressures, can cause extreme bodily harm. Never allow any gas stream to be directed at any part of your body.**

### **Warning**

**Never expose the sensor to pressures above atmospheric pressure (0 psi) or you may cause damage to the sensor and/or receive false readings. Damaged Sensors will not provide accurate gas analysis. Inaccurate gas analysis can lead to serious personal injury or death.**

#### **4.1 Programming Procedures**

Keep the “Pro” button pressed for more than two seconds and then release the button. “Pr” should display for two seconds and then the display will change to AL 1 and alternate with the 3 digit set value.

It is possible to program:

- **AL 1** First alarm point expressed in ppm of Moisture in concentration
- **AL 2** Second alarm point expressed in ppm of Moisture in concentration
- **FSC** Value expressed in ppm of moisture in concentration corresponding to the current output full scale value 4-20mA output if available
- **PrE** ambient pressure expressed in mBar. Default value is 1013

At the end of the programming procedure the display will show “End” and the instrument will display the moisture in percentage of relative humidity content in the gas mix.



Below are the actual screen views of each of the modes.



#### 4.2 Alarm Setting (AL 1 & AL 2)

- 1.) Press the "Prog" button for more than two seconds and then release the button. On the display will appear "Pr" for two seconds, then "AL1" will appear and be ready for changing the value of the first alarm point. After a second the display will show the value of "AL1" H<sub>2</sub>O ppm current setting. Default is 1999.
- 2.) The blinking digit shows the cursor position.
- 3.) Press the "Prog" button to increase the value (from 0 to 9)
- 4.) Press the "Adjust" button to move the cursor to the next digit, the "Adjust" button will be used to cycle through the rest of the digits.
- 5.) To complete your entry and save the H<sub>2</sub>O ppm value, press the "On/Off" button. You will then automatically jump to "AL 2" programming view.
- 6.) Repeat steps 3 through 5 to modify and save the "AL 2" H<sub>2</sub>O ppm desired value.
- 7.) Once programming of "AL 2" is complete you will be in the "FSC" Value Screen and ready for programming this value. To jump to the end continue to press the "On/Off" button until the "end" screen appears.

### 4.3 Full Scale Value Setting (FSC)

Once the alarms have been set the Pro H<sub>2</sub>O Analyzer goes to “FSC” view so that you can change the analog full scale value. The FSC value sets the span of the instrument for the 4-20 mA output, if available. The value is related to PPM value.

It is not necessary to modify this value which is factory set. This value can be changed in the same manner as the Alarm settings:

- 1.) Press the “Prog” button for more than two seconds and then release the button. On the display will appear “Pr” for two seconds, then “AL 1” will appear. Press the On/Off button to cycle through the Alarm settings until you reach the “FSC” view. The “FSC” screen and a 3 digit value will alternate for a few seconds and the Pro CO Analyzer will be ready for adjusting the “FSC” Value.
- 2.) The blinking digit shows the cursor position.
- 3.) Press the “Prog” button to increase the value (from 0 to 9)
- 4.) Press the “Adjust” button to move the cursor to the next digit, the “Adjust” button will be used to cycle through the rest of the digits.
- 5.) To complete your entry and save the FSC value, press the “On/Off” button. You will then automatically jump to “PrE” programming view. To continue pass this to the end press the On/Off button until the “End” screen appears.

### 4.4 Ambient Pressure Value (PrE)

After the “FSC” is set the Pro H<sub>2</sub>O Analyzer goes to “PrE”, this is the Ambient Pressure value, measured in mBar. Default is 1013 It is not necessary to modify this value. The display will have a blinking digit which shows the current cursor position.

- 1.) Press the “Prog” button for more than two seconds and then release the button. On the display will appear “Pr” for two seconds, then “AL 1” will appear. Use the On/Off button to cycle through the various settings until you reach the PrE” screen. The 4th digit value will blink and is the first value that can be changed.
- 2.) The blinking digit shows the cursor position.
- 3.) Press the “Prog” button to increase the value (from 0 to 9)
- 4.) Press the “Adjust” button to move the cursor to the next digit, the “Adjust” button will be used to cycle through the rest of the digits.
- 5.) To complete your entry and save the PrE value, press the “On/Off” button. You will then automatically jump to “End” programming view.

## 5.0 Calibration in 0% humidity dry gas

It is possible to calibrate the humidity sensor with a certified dry GAS containing 0% of relative humidity. Attach dry gas to flow inlet of analyser, wait for at least 1 minute and press at the same time ON/OFF and Adjust button. You will see on display CAL Att and the value will be 0, and on the display there will be an up arrow symbol.

For coming back the original factory calibration, follow the Reset procedure stated below in 8.0. The instrument will forget the last calibration operation once reset.

For resetting the instrument to the original factory settings (rES), power on the instrument pressing at the same time for few seconds the ON/OFF and the Adjust button.



**Calibration gas must be certified Moisture free for accurately calibrating the moisture analyzer.**



## **Danger**

**As soon as the analyzer alarm is tripped, shut down your compressor system and replace all of your filter cartridges in the compressor system.**

### **6.0 Threshold Alarms**

The Alarm function must be activated every time the unit is powered on. To activate, wait until the unit has cycled through its startup and is steadily displaying the analyzer's reading. Press and hold the On/Off and Prog buttons simultaneously until the display flashes ALN, then ON. The alarm function is active when a triangle is present in the upper left of the analyzer display.

Should the Moisture content exceed the threshold alarms (AL1 or AL2) the instrument will go into alarm mode and will activate the (optional) relays output (open collector max 100mA) and internal buzzer. The display will show the trespassed alarm and actual measured value. To stop the audible alarm, press any key. In this event the Pro H<sub>2</sub>O Analyzer will remain in alarm mode until the analyzed value goes below the alarm.

The relay output typically is used to shut down the compressor or activate external optional alarms. Nuvair can supply the necessary components to adapt your compressor to the relay or provide them at the time of install on a new compressor.

### **7.0 Powering Off**

At the home or gas reading screen, hold down the On/Off button for a couple of seconds. The Analyzer will display "OFF" and then go blank.

### **8.0 Factory Reset**

In case it is necessary to reset the Pro H<sub>2</sub>O Analyzer to the factory settings, power on the Analyzer pressing at the same time for more than one second the "On/Off" and "Adjust" buttons. On the display will appear "res" and the instrument will go to the reading page.

## **Warning**

**Resetting the Analyzer will result in all user programmed alarms and calibration being erased and set at factory defaults.**

## 9.0 Maintenance

### 9.1. Analyzer Care

#### **Warning**

**Analyzers immersed in liquid or stored in wet environments may not operate properly. This may result in incorrect readings. Incorrect gas analysis may result in personal injury or death.**

#### **Warning**

**Protect the analyzer from excessive shock and impact. Excessive shock and impact may result in incorrect readings. Incorrect gas analysis may result in personal injury or death.**

#### **Warning**

**Protect the analyzer from exposure to hyperbaric environments. Exposure to hyperbaric environments may result in incorrect readings. Incorrect gas analysis may result in personal injury or death.**

- Do not clean Analyzer with anything other than a damp soft cloth.
- Do not immerse in liquid, leave unprotected outside, or store in a wet environment.
- Protect Analyzer from excessive shock and impact.
- Protect Analyzer from excessive exposure to sunlight and extreme temperatures.
- Do not use the Analyzer in a hyperbaric environment.

### 9.2 Sensor Cleaning

Do not touch or rub the sensing element during the cleaning process. It is strongly advised NOT to try cleaning the sensor by mechanical means, such as rubbing the sensor with cotton material!

The best way to clean the sensor is to use an ultrasound cleaner. This is a commercially available piece of equipment, which generates ultrasound vibrations in a small bath. The cleaning agent in the bath should be 50% isopropyl alcohol + 50% distilled water. Remove the filter cap from the tip of the sensing probe. This has to be done very carefully in order to avoid damaging the sensing element.

Hold onto the sensing probe and slowly stir the tip of the sensing probe in the ultrasound bath for about 1 minute. The sensing element, the leads and the socket should be immersed in the liquid. If an ultrasound cleaning bath is not available, stir the sensor as described above in a container with a mixture of 50% isopropyl alcohol + 50% distilled water for approx. 2-3 minutes. This procedure suffices for “normal soiling”.

In the event of extreme soiling – which can be seen on the humidity sensing element with the naked eye – continue the operation until the pollutants are dissolved. After the cleaning procedure with isopropyl alcohol, stir the tip of the sensing probe in a container with distilled water for about 30 seconds and then allow it to dry at room temperature.

## 10.0 Troubleshooting

SYMPTOM	REASON	SOLUTION
Battery symbol	Low Battery	Change the battery
No display	Switched off Bad connection Low Battery	Switch on Check display/ battery connection Change the battery
Reading erratic	Pressure on sensor Radio transmission Sensor old or faulty Condensation on sensor.	Check flow Move unit away Change sensor Dry in air
Display segments missing	Display faulty	Return to dealer
Reading drifts	Rapid temperature change	Stabilize temperature & recalibrate

## 11.0 Relay Output Schematics

**4-20mA Connections:** The relay output uses a special “Mini Jack” plug that can be purchased separately from Nuvair. Insert the plug into the output jack. Connections diagram below for additional wiring.

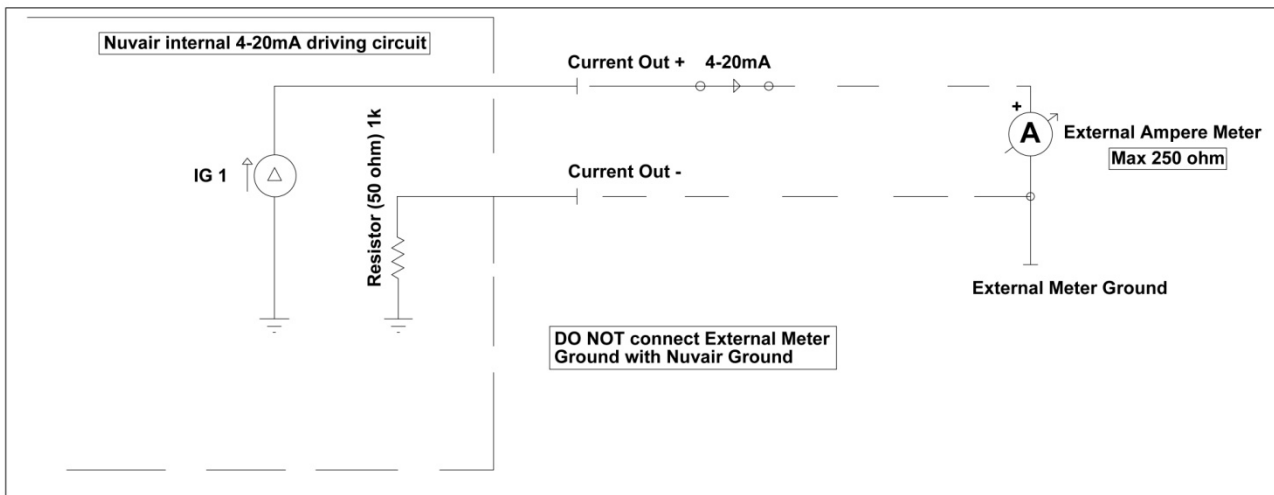

### Warning

The plug should be connected or disconnected when the instrument is switched off, or the instrument will automatically switch off.

### Open Collector Connections:

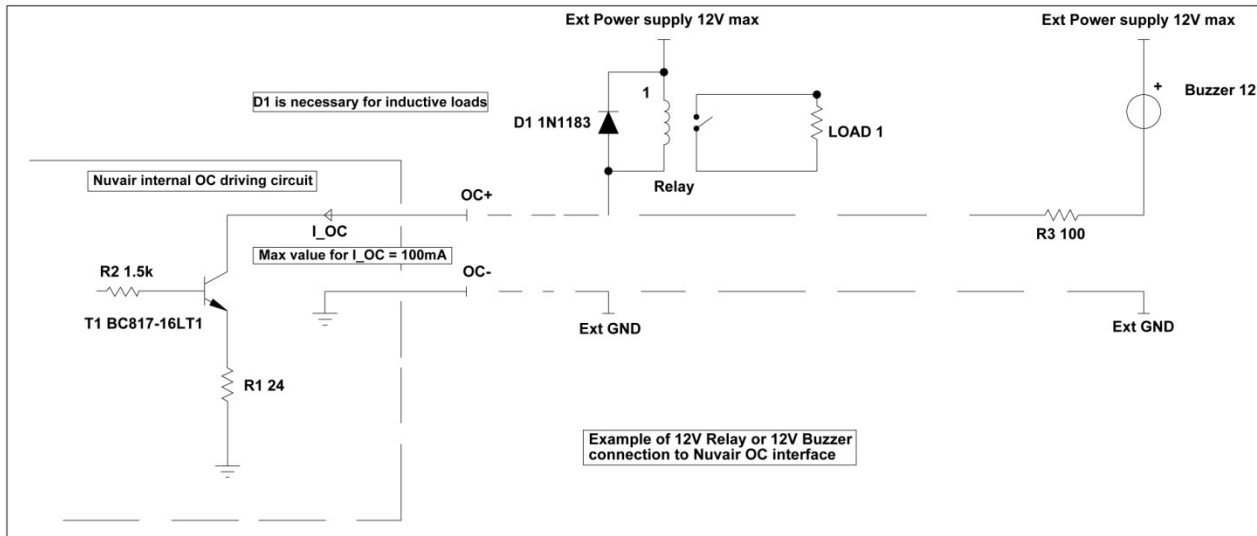

## 12.0 Analyzer Specifications

Relative Humidity Range:	0 – 100% relative humidity
Resolution of Analog Output:	2 $\mu$ A
Display Accuracy:	5 ppm + 9 % from measured value
Additional Error Temperature:	$\pm$ 0.1 % rh/K for less than 10 °C and greater than 40 °C
Additional Error RH:	$\pm$ 0.25% rh/%rh for less than 10% rh and greater than 90% rh

Relative Humidity Sensor Type:	Capacitive
Expected Sensor Life, Room Air:	3 Years
Power:	110/220 V Wall Plug-in or DIN Rail
Response Time:	<5 min -4° to -76° F (-20° to -60° C) <15 sec -76° to -4° F (-60° to -20° C)
Stabilization Time:	
Operating Temperature:	-40° to 158° F (-40° to 70° C)
Storage Temperature:	-40° to 140° F (-40° to 60° C)
Operating Pressure:	0 to 80 bar

Note: All specifications are at ambient / sea level, 77°F / 25°C.

## **Nuvair Pro H<sub>2</sub>O Warranty**

Nuvair extends a limited warranty, which warrants the Pro H<sub>2</sub>O to be free from defects in materials and workmanship under normal use and service for a limited period. The Pro H<sub>2</sub>O is warranted according to the terms as set forth below. This warranty is not transferable.

Nuvair will, at its discretion and according to the terms as set forth within, replace or repair any materials which fail under normal use and service and do not exhibit any signs of improper maintenance, misuse, accident, alteration, weather damage, tampering, or use for any other than the intended purpose. Determination of failure is the responsibility of Nuvair, which will work together with the customer to adequately address warranty issues. When any materials are repaired or replaced during the warranty period, they are warranted only for the remainder of the original warranty period. This warranty shall be void and Nuvair shall have no responsibility to repair or replace damaged materials resulting directly or indirectly from the use of repair or replacement parts not approved by Nuvair.

### **Terms:**

Nuvair warrants the Pro H<sub>2</sub>O to be free from defects in material and workmanship for a period of twelve (12) months from date of purchase. The warranty covers parts and labor.

A warranty registration card, supplied with system documentation, must be filled out and submitted to Nuvair for the warranty to be registered. If the warranty registration card is not received within ten (10) days of purchase, the warranty will begin with the date of manufacture by Nuvair.

### **Maintenance Items:**

Any materials which are consumed, or otherwise rendered not warrantable due to processes applied to them, are considered expendable and are not covered under the terms of this policy. This includes batteries.

### **Return Policy:**

Application for warranty service can be made by contacting Nuvair during regular business hours and requesting a Return Material Authorization number. Materials that are found to be defective must be shipped, freight pre-paid, to the Nuvair office in Oxnard, California. Upon inspection and determination of failure, Nuvair shall exercise its options under the terms of this policy. Warranty serviced materials will be returned to the customer via Nuvair's preferred shipping method, at Nuvair's expense. Any expedited return shipping arrangements to be made at customer's expense must be specified in advance.

### **Limitation of Warranty and Liability:**

Repair, replacement or refund in the manner and within the time provided shall constitute Nuvair's sole liability and the Purchaser's exclusive remedy resulting from any nonconformity or defect. Nuvair shall not in any event be liable for any damages, whether based on contract, warranty, negligence, strict liability or otherwise, including without limitation any consequential, incidental or special damages, arising with respect to the equipment or its failure to operate, even if Nuvair has been advised of the possibility thereof. Nuvair makes no other warranty or representation of any kind, except that of title, and all other warranties, express or implied, including warranties of merchantability and fitness for a particular purpose, are hereby expressly disclaimed. No salesman or other representative of Nuvair has authority to make any warranties.





Nuvair  
Phone: +1 805 815  
4044 Fax: +1 805 486  
0900 1600 Beacon  
Place Oxnard, CA  
93036 USA  
[info@nuvair.com](mailto:info@nuvair.com)  
[www.nuvair.com](http://www.nuvair.com)