



User Manual

# **Pro He Alarm**

Helium Analyzer

Rev. 08.22

If you have any questions on this equipment please contact Technical Support at:

Nuvair  
1600 Beacon Place  
Oxnard, CA 93033

Phone: +1 805 815 4044  
Fax: + 805 486 0900  
Email: [info@nuvair.com](mailto:info@nuvair.com)

Hours: Monday through Friday  
8:00 AM to 5:00 PM PST USA

## Warning

**This User Manual contains important safety information and should always be available to those personnel operating this equipment. Read, understand, and retain all instructions before operating this equipment to prevent injury or equipment damage.**

Every effort was made to ensure the accuracy of the information contained within this manual; however, we retain the right to modify its contents without notice. If you have problems or questions after reading the manual, stop and call for information.

## Warning

**Never expose gas sensors to pressure or you may cause damage and/or false readings. Damaged sensors will not provide accurate gas analysis. Most gas analyzers can be used to analyze a regulated gas sample flow, the contents of a gas cylinder, or the flow from a regulator. The flow rate of gas must equal 1-5 L/min. To produce this flow, a Flow Restrictor and Regulator may be required. A faulty Flow Restrictor can lead to a false analyzer reading. Flow Restrictors should be regularly tested with a Flow Meter. Inaccurate gas analysis can lead to serious personal injury or death.**

## Table of Contents

- 1.0 Introduction
- 2.0 System Description
  - 2.1 Controls
  - 2.2 Display
  - 2.3 Alarm
  - 2.4 Sensor
  - 2.5 Batteries
  - 2.6 Flow Adapter Cap
- 3.0 Calibration
- 4.0 Operation
  - 4.1 Sample Flow Method
  - 4.2 Programming Procedures
  - 4.3 Alarm Setting
  - 4.4 Full Scale Value Setting
  - 4.5 Auto Off Delay Time Setting
- 5.0 Threshold Alarms
- 6.0 Powering Off
- 7.0 Factory Reset
- 8.0 Maintenance
  - 8.1 Analyzer Care
  - 8.2 Battery Replacement
- 9.0 Spares and Accessories
  - 9.1 Calibration Equipment
  - 9.2 110V/220V Charger for Lithium Battery powered Pro He Analyzer
- 10.0 Troubleshooting
- 11.0 Relay Output Schematics

Appendix

- Analyzer specifications
- Charger specifications
- Warranty

## 1.0 Introduction

This manual will assist you in the proper set-up, operation and maintenance of the Pro HE Helium Analyzer. Be sure to read the entire manual.

Throughout this manual we will use certain words to call your attention to conditions, practices or techniques that may directly affect your safety. Pay particular attention to information introduced by the following signal words:

### **Danger**

Indicates an imminently hazardous situation, which if not avoided, will result in serious personal injury or death.

### **Warning**

Indicates a potentially hazardous situation, which if not avoided, could result in serious personal injury or death.

### **Caution**

Indicates a potentially hazardous situation, which if not avoided, may result in minor or moderate injury. It may also be used to alert against unsafe practices.

### **Notice**

Notifies people of installation, operation or maintenance information which is important but not hazard-related.

#### Warnings Graphics Defined:



Gas Inhalation



Skin damage

## 2.0 System Description

The Pro HE Helium Analyzer measures helium (He) levels in gases in the range of 0 to 100% of volume with a .1% resolution. It can be used to measure the He content in all breathing gas mixes. The Analyzer is designed to verify helium concentration in stored gas cylinders as well as to monitor continuous flow of gas from a compressor. The Analyzer is a moisture and impact resistant unit compatible with outdoor and marine environments.



### **! Danger**

**Helium is a colorless, odorless, tasteless gas that will not support life. Exposure to Helium can lead to unconsciousness and death.**

The Analyzer is battery powered or 110/230V and includes an internally mounted sensor with audible & visual alarm. The water-resistant case includes a digital display and controls that are environmentally sealed.

The Analyzer uses a Flow Adapter Cap and Flexible tubing to deliver sample gas to the Sensor. Pressurized gases must be regulated to avoid damage to the analyzer. Use of this Analyzer in a hyperbaric chamber will void the owner's warranty.

The Analyzer is self-calibrating and ready for use after powering on. Certified calibration gas should be used periodically to confirm the accuracy of the analyzer sensor and electronics are working properly.



### **! Warning**

**This analyzer is designed for use at atmospheric pressures only. It is not designed for exposures in a hyperbaric chamber. Use of this analyzer in a hyperbaric chamber will result in incorrect readings and may damage the unit.**

### **! Warning**

**Although the Analyzer is a rugged instrument, careless handling or abuse may result in damage to the Analyzer resulting in inaccurate gas analysis. Inaccurate gas analysis can lead to serious personal injury or death.**

### **! Notice**

**Extreme Helium exposure levels directed at the Analyzer sensor may damage the sensor.**

2.0 Description



Model: 9627

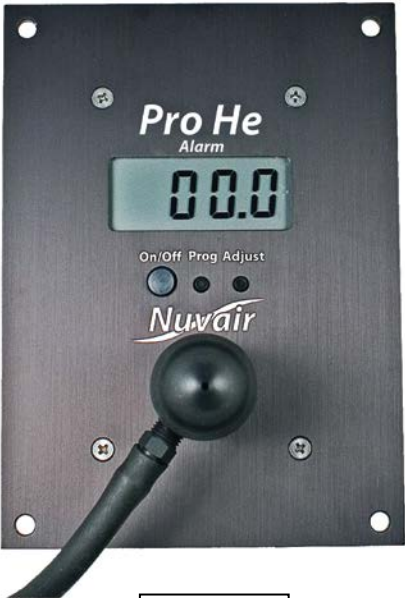

Model: 9628



Model: He

Model He with rechargeable Lithium Polymer battery. Only use Nuvair supplied charger for this battery.





## 2.1. Controls



## 2.2. Display

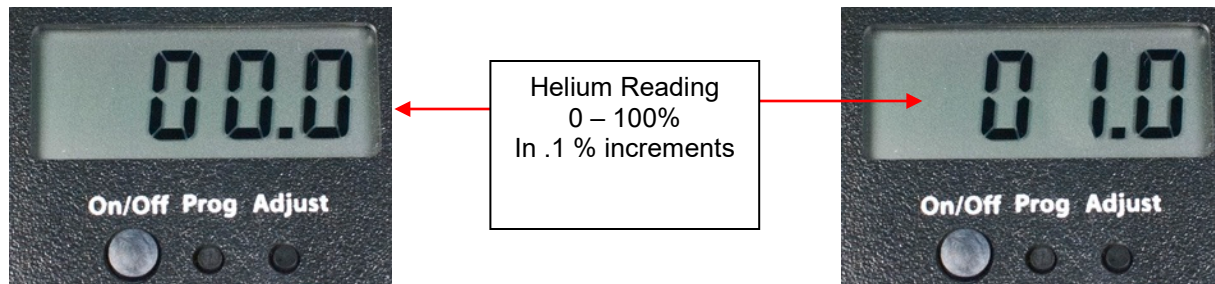

## 2.3. Alarm

The Analyzer includes an audible and visual alarm that is activated when the Sensor reaches the alarm set points which are user programmed. The alarm will not clear until the concentration of He drops below user programmed set points.

## 2.4. Sensor

The Analyzer uses a "Thermal Conductive" Helium sensor to measure He content in gases. The Sensor is designed for use at atmospheric pressure (0 P.S.I.). The gas mixture to be analyzed must be regulated to .5-1.0 LPM, and any potential for pressure or vacuum must be avoided.

## 2.5. Batteries

The Pro He rechargeable model uses a "110/230V" charger with a Lithium Polymer rechargeable battery. A fully charged battery should last up to 24 hours. Recharge takes about 4 hours. **DO NOT LEAVE UNIT UNATTENDED WHILE CHARGING and UNPLUG ONCE CHARGED.** The battery is located inside the Analyzer and is user-replaceable. Lithium battery models should have battery removed any time the Analyzer will be stored without use for extended periods of time.

Screen will blink alternately from "000" to "bAt" at start up when battery is low.

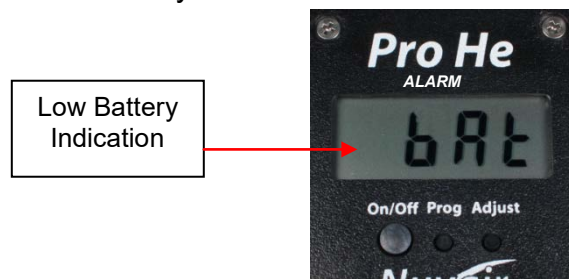

## 2.6. Flow Adapter Cap

The Analyzer includes a Flow Adapter Cap with flexible tubing and flow orifice. It attaches to the Sensor port and is sealed by an o-ring. It can be used to direct the gas sample flow to the Sensor via one of two methods:



Flow to the sensor needs to be restricted to .5-1liter. Increased flow will create faulty readings. Nuvair offers flow restrictors to accomplish this task. See appendix.

## 3.0 Calibration

### Warning

**Analyzer calibration must be verified on a weekly basis. Improper calibration may result in an incorrect reading, exposing the user to dangerous levels of Helium. Exposure to Helium can lead to unconsciousness and death.**

### Warning

**This Analyzer must always be checked against a calibration gas and used with gases regulated and supplied at atmospheric pressure (0 P.S.I.). Use of gases at higher pressures may result in incorrect readings and may damage the Analyzer. Incorrect readings may expose the user to high levels of carbon Dioxide resulting in personal injury or death.**

### Warning

**Checking Calibration or use of the Analyzer with a low battery may result in inaccurate readings. Inaccurate gas analysis can lead to serious personal injury or death.**

### Notice

**If the Analyzer has been subjected to a recent change in ambient temperature, allow it to stabilize for one hour before checking calibration.**

Verify calibration on a weekly basis. Breathing gas applications require the use of a certified He calibration gas and flow rate of 0.5-1 L/min. The equipment to produce this flow is available from Nuvair. See Spares and Accessories section. To assure the greatest accuracy for other applications, use the calibration gas concentration closest to the expected concentration in the gas being measured.

Should the unit begin to display readings other than the helium percentage of the calibration test gas, perform a Factory Reset as outlined in Section 7.



## 4.0 Operation

Prior to each Analyzer use:

- 1) Turn unit on (hold on/off for 3 sec) and monitor Display for low battery warning. Charge battery immediately if warning appears. The display will show “On”, “(version of software)” and then “Att” and then display the current He level sensed by the analyzer sensor.

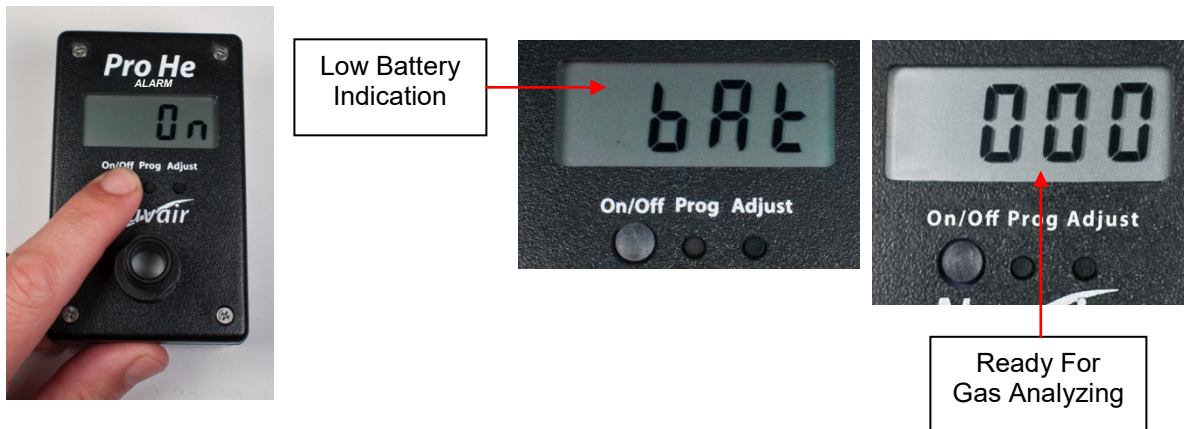

- 2) Cycle through the current settings of the analyzer.
  - a. Hold down the “Prog” button for 2 seconds then use the “On/Off” button to cycle through the two Threshold Alarm Values set, Full Scale Value, Auto shutdown time, and end.
  - b. Adjust Alarm values at this time if needed see “4.2”
- 3) Confirm calibration of Analyzer using “Calibrated Test Gas”

Tip: You can check the battery life and current temperature by holding Adjust button for 3 seconds. The display will alternate from battery life to current temperature (Celsius) twice before returning the home screen.

### Warning

**Gas, even under moderate pressures, can cause extreme bodily harm. Never allow any gas stream to be directed at any part of your body.**

### Warning

**Never expose the sensor to pressures above atmospheric pressure (0 P.S.I.) or you may cause damage to the sensor and/or receive false readings. Damaged Sensors will not provide accurate gas analysis. Inaccurate gas analysis can lead to serious personal injury or death.**

The Pro HE can be used to monitor an enclosed space or to analyze a regulated gas sample flow, the contents of a gas cylinder, or the flow from a regulator:

- If monitoring an enclosed space, simply remove the Flow Adapter Cap to expose the Sensor face to the atmosphere and allow 15 seconds for the Display reading to stabilize.
- If analyzing a gas flow, the Sample Flow Method is the preferred method. The flow rate must equal 0.5 to 1 L/min at atmospheric pressure (1 bar). To produce this flow, a Flow Restrictor and Regulator may be required. Contact Nuair if you need assistance.

### 4.1. Sample Flow Method of Checking Calibration (Preferred)

Step 1. Attach Flexible Tubing to Gas Sample Flow of 0.5 to 1 L/min

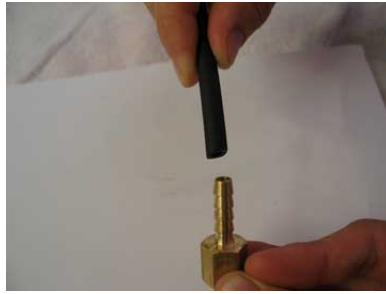

Step 2. Verify that Gas is Flowing Out Holes in Flow Adapter Cap



Step 3. Allow Display Reading to Stabilize

Step 4. Record Reading while Gas is Flowing



Nuvair offers He test gas for confirming calibration. See kits in the addendum for more information.

**Testing Gas must contain a known amount of Helium for calibration test to succeed.**

Flow Restrictor/  
Regulator  
Assembly

1000 PPM He  
Calibration Gas  
Canister



Nuvair  
Calibration Gas  
Specs:  
CO 10 ppm  
He 1000 ppm  
Nitrogen Balance

## 4.2. Programming Procedures

Keep the “Prog” button pressed for more than two seconds and then release the button. “Pr” should display for two seconds and then the display will change to AL 1 and alternate with the 3 digit set value.

It is possible to program:

- **AL 1** Low alarm point expressed in ppm of Helium concentration
- **AL 2** High alarm point expressed in ppm of Helium concentration
- **FSC** Value expressed in ppm of Helium concentration corresponding to the current output full scale value (20mA). 4mA always correspond to 1999 ppm He concentration.
- **tOn** Time on value- This is the time the analyzer will stay on before auto powering off.

At the end of the programming procedure the display will show “End” and the instrument will display the Helium content in the gas mix.

Below are the actual screen views of each of the modes. (\*Calib button say as adjust)

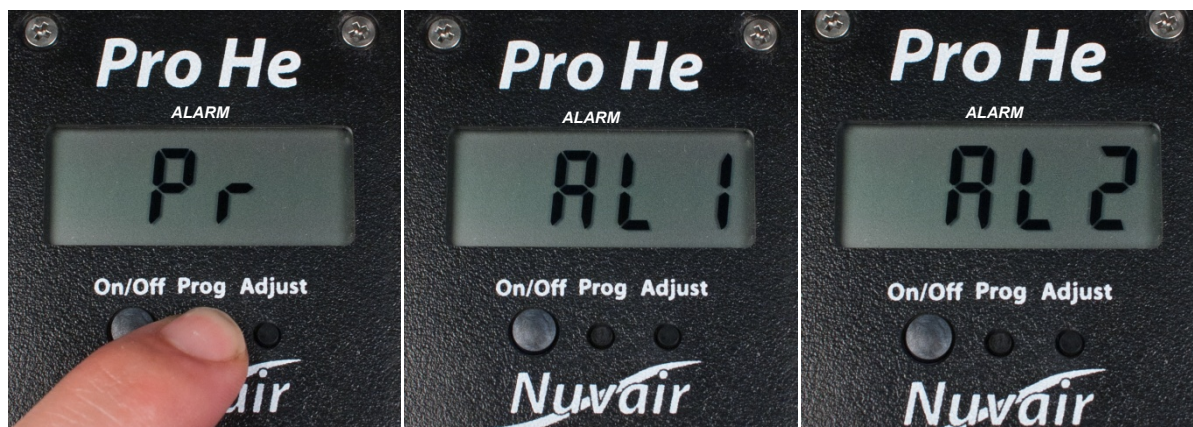

Program

Alarm 1

Alarm 2



Full Scale Value

Auto Time Off

End



### 4.3. Alarm Setting (AL 1 & AL 2)

- 1.) Press the “Prog” button for more than two seconds and then release the button. On the display will appear “Pr” for two seconds, then “AL1” will appear and be ready for changing the value of the alarm percentage. Default is 100% and if either alarm is set at 100% the alarm will be excluded. After a second the display will show the value of “AL1” He % current setting.
- 2.) The blinking digit shows the cursor position.
- 3.) Press the “Prog” button to increase the value (from 0 to 9)
- 4.) Press the “Adjust” button to move the cursor to the next digit, the “Adjust” button will be used to cycle through the rest of the digits.
- 5.) To complete your entry and save the He % value, press the “On/Off” button. You will then automatically jump to “AL 2” programming view.
- 6.) Repeat steps 3 through 5 to modify and save the “AL 2” if desired or leave at 100% to exclude alarm.
- 7.) Once programming of “AL 2” is complete you will be in the “FSC” Value Screen and ready for programming this value. To jump to the end continue to press the “On/Off” button until the end screen appears.

### 4.4. Full Scale Value Setting (FSC)

Once the alarms have been set the Pro He Analyzer goes to “FSC” view so that you can change the analog full scale value. It is not necessary to modify this value which is factory set at 100. This is the Helium concentration corresponding to 20 mA on the analog output. 4mA is the value at 0% of Helium concentration. This value can be changed in the same manner as the Alarm settings:

- 1.) Press the “Prog” button for more than two seconds and then release the button. On the display will appear “Pr” for two seconds, then “AL 1” will appear. Press the On/Off button to cycle through the Alarm settings until you reach the “FSC” view. The “FSC” screen and a 3 digit value will alternate for a few seconds and the Pro He Analyzer will be ready for adjusting the “FSC” Value.
- 2.) The blinking digit shows the cursor position.
- 3.) Press the “Prog” button to increase the value (from 0 to 9) (0-19 on the third value)
- 4.) Press the “Adjust” button to move the cursor to the next digit, the “Adjust” button will be used to cycle through the rest of the digits.
- 5.) To complete your entry and save the FSC value, press the “On/Off” button. You will then automatically jump to “tOn” programming view.

### 4.5. Auto Switch Off Delay Time (tOn)

In this setting it is possible to change the auto off delay time of the Analyzer. The display will show 180 seconds default, We manually change this to 600 seconds before shipping. This value is changed by the same procedure as the Alarm settings, follow procedure above in 4.3. This setting can be adjusted from 0 to 1999 seconds. To keep the instrument from turning off the Analyzer time should be set to “000” seconds. To complete your entry and move to the end screen press the power on/off button when programming is complete.

## **Warning**

**The analyzer will shut off after the set time value is reached that is programmed into the analyzer. If you are using the analyzer for continuous blending, set the value to “000” to prevent the analyzer from shutting off automatically. With the analyzer off inaccurate gas mixture could take place and lead to a death. Always analyze mixed gas before you dive.**

## 5.0. Threshold Alarms

The He analyzer will alarm once the gas goes over the alarm set point (AL1 or AL2). Once the gas is above the AL1 or AL2 set point the analyzer will go into alarm mode until the gas value drops below the set point during the gas analyzation. Should the Helium gas trip the alarms (AL1 or AL2) the instrument will go into alarm mode and will activate the (optional) relays output (open collector max 100mA) and the internal buzzer. The display will show the trespassed alarm and the actual measured value. To stop the audible alarm, press any key. In this event the Pro He Analyzer will remain in alarm mode until the analyzed value reads below the AL1 and AL2 set points.

The relay output typically is used to shut down the compressor. Nuair can supply the necessary components to adapt your compressor to the relay or provide them at the time of install on a new compressor.

## 6.0. Powering Off

At the home or gas reading screen, hold down the On/Off button for a couple of seconds. The Analyzer will display "OFF" and then go blank.



## 7.0. Factory Reset

In case it is necessary to reset the Pro He Analyzer to the factory settings, or the displayed Helium Percentage does not correlate with the content of your calibration test gas, follow this procedure to reset the unit:

1. Power on the unit by holding down the On/Off button until the display turns on.
2. Wait until the display has stabilized and the unit is ready to analyze.
3. Record any alarm levels or Auto Off time that are programmed and retain for later use. Cycle back to the home screen.
4. Press the On/Off and Adjust buttons at the same time and hold until the display changes.
5. Release the buttons. The unit should now be reset.
6. Test the Analyzer with calibrated test gas to ensure accuracy. If the analyzer still does not display an accurate reading, contact Nuair for repair or replacement of the unit.
7. If the analyzer is now accurate, you may now re-program any alarms and Auto Off time.

## ⚠ Warning

**In case of reset, the instrument will delete all the alarms settings and the Auto Off time value. Before using the instrument after a reset, it may be necessary to program again the alarm values and the Auto Off value. You should confirm your calibration with a certified testing gas immediately after a reset before using.**

## 8.0. Maintenance

### 8.1. Analyzer Care

#### **Warning**

Analyzers immersed in liquid or stored in wet environments may not operate properly. This may result in incorrect readings. Incorrect gas analysis may result in personal injury or death. The Lithium Polymer battery may present a fire hazard if the battery gets wet.

#### **Warning**

Protect the analyzer from excessive shock and impact. Excessive shock and impact may result in incorrect readings. Incorrect gas analysis may result in personal injury or death.

#### **Warning**

Protect the analyzer from exposure to hyperbaric environments. Exposure to hyperbaric environments may result in incorrect readings. Incorrect gas analysis may result in personal injury or death.

### 8.1. Analyzer Care

- Do not clean Analyzer with anything other than a damp soft cloth.
- Do not immerse in liquid, leave unprotected outside, or store in a wet environment.
- Protect Analyzer from excessive shock and impact.
- Protect Analyzer from excessive exposure to sunlight and extreme temperatures.
- Do not use the Analyzer in a hyperbaric environment.



## 8.2. Battery Replacement

### Notice

Be sure to dispose of spent or damaged Battery properly, according to local regulations. The following pictures illustrate the steps required to replace the batteries in the Analyzer.

Step 1. Remove Screws

Step 2. Remove Back Cover

Step 4. Replace Back Cover - Do Not Pinch Wires

Step 5. Reinstall Screws



Step 3. Remove & Replace Old Battery

Step 6. Turn Analyzer On

Step 7. Perform Calibration



**“LB” Model:** Remove four nuts and pull out aluminum plate. Under this plate is the Lithium Polymer battery. Contact Nuair for a replacement battery.

4 - Nuts must be removed to access battery



Battery

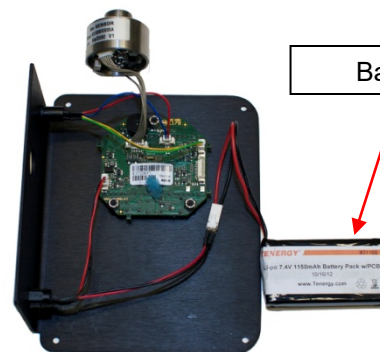

### 8.3. Sensor Replacement

Should the sensor become faulty, contact Nuair for repair or replacement.

## Warning

Replace sensor when the Helium analyzer is unable to correctly analyze Helium gas. The use of a damaged sensor may cause dangerous analysis and lead to death. Wrong Helium analysis may lead to death. Always contact Nuair for repairs. Do not use any other helium sensor brands for replacement.

## Caution

### 9.0 Spares

#### 9.1. Calibration Equipment

Calibration check requires certified He calibration gas to be delivered at a specific flow rate and pressure.

A variety of calibration gas canisters are available from Nuair, with compatible Flow Restrictor/ Regulator assemblies to regulate the gas.

Flow Restrictor/  
Regulator  
Assembly



#### 9.2. 110V/230V Charger for Lithium Battery powered Pro He Analyzer

VERY IMPORTANT YOU ONLY USE Nuair SUPPLIED MODEL: H00740003-XX-W1 USING ANY OTHER CHARGER COULD CAUSE A FIRE.



## 10.0 Troubleshooting

SYMPTOM	REASON	SOLUTION
Battery symbol	Low Battery	Change the battery
No display	Switched off Bad connection Low Battery	Switch on Check display/ battery connection Change the battery
Reading erratic	Pressure on sensor Radio transmission Sensor old Condensation on sensor.	Check flow Move unit away Return to Dealer Dry in air
Display segments missing	Display faulty	Return to dealer
Reading drifts	Rapid temperature change	Stabilize temperature & recalibrate

## 12.0 Relay Output Schematics

**4-20mA Connections:** The relay output uses a special “Mini Jack” plug that can be purchased separately from Nuvair. Insert the plug into the output jack. Connections diagram below for additional wiring.

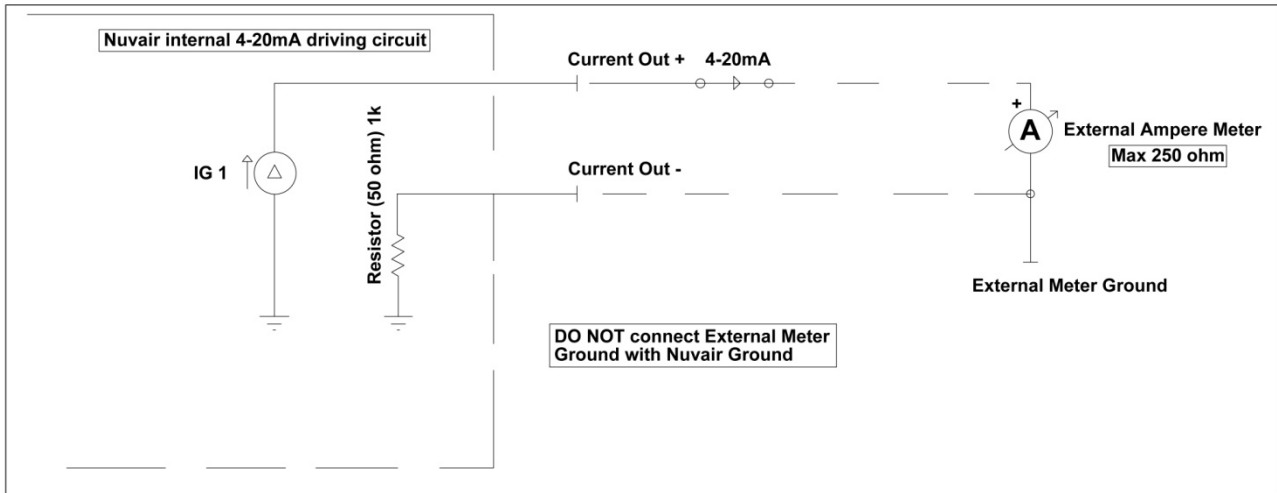

### Warning

The plug should be connected or disconnected when the instrument is switched off, or the instrument will automatically switch off.

## Open Collector Connections:

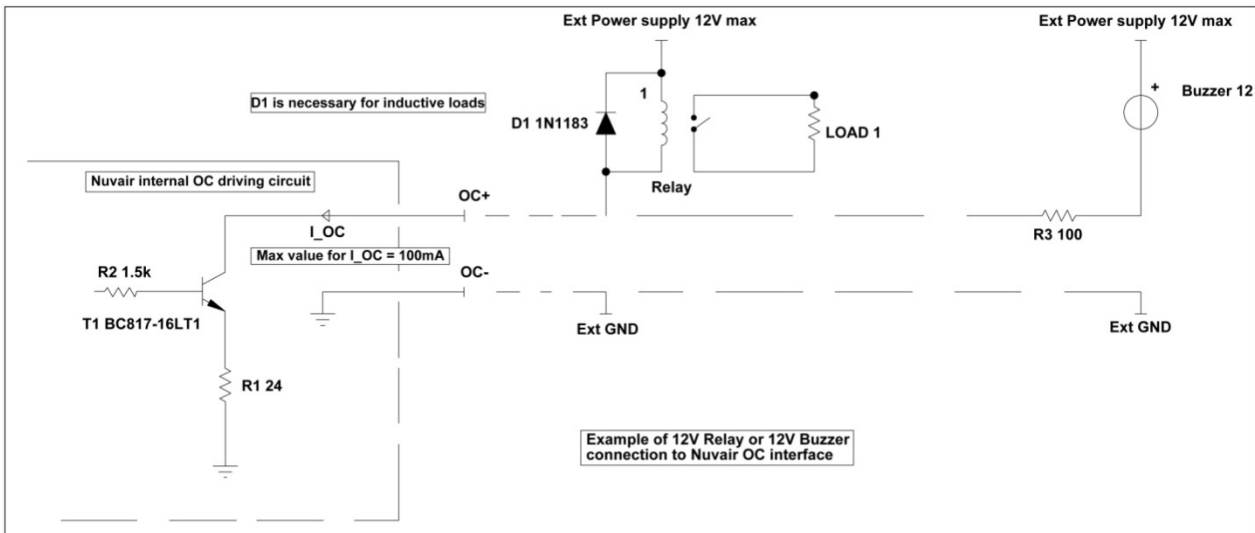

## Appendix

### Analyzer Specifications

Resolution:	0 – 100% Helium in air or nitrogen or oxygen
Alarm Set Point:	Whatever % desired of He
Display Accuracy:	+/- 2%
Sensor Type:	Thermal Conductive Technology
Expected Sensor Life, Room Air:	2 Years
Power:	7.4V Li, or optional 110/230v electric
Battery Life:	6 hrs+ with Lithium battery
Response Time:	Less than 10 Seconds to 90% of Final Value
Stabilization Time:	10 Minutes Max Accuracy
Operating Temperature:	41 to 104°F (5 to 40°C)- Will work outside this range with decreased accuracy.
Storage Temperature:	5 to 122°F (-15 to 50°C)
Operating Pressure:	Not to Exceed 1 Atmosphere Absolute (0 psi)
Humidity:	0-90% Non Condensing. Don't allow moisture to build up on the sensing surface.

Note: All specifications are at ambient / sea level, 77°F / 25°C and subject to change without notice

### Charger Specifications for Lithium Polymer rechargeable battery Models

#### Features:

- 110V-240V AC input for worldwide power support
- Constant charging current for faster charging
- Stabilized output, low ripple
- Safety Protection:
  - Over Voltage Protection
  - Short Circuit Protection
  - Output reverse input protection
- The charger will cut off automatically if battery is fully charged (1/10C) and indicated by LED

In charging mode    **RED** LED  
 Battery Full        **GREEN** LED

#### Specifications:

Input: AC 100-240V 50-60Hz

Output: DC 8.1V

Charging Current: 300mA

#### WARNING:

- Charge only Nuair 7.4V Li-ion rechargeable battery pack with this charger
- Don't expose the product to rain or humidity to prevent from electric shock
- It is normal for the product to get slightly warm when in use
- Keep out of reach of children
- Don't touch any part of the product during charging to prevent electric shock.

## Nuvair Pro HE Warranty

Nuvair extends a limited warranty, which warrants the Pro HE to be free from defects in materials and workmanship under normal use and service for a limited period. The Pro He is warranted according to the terms as set forth below. This warranty is not transferable.

Nuvair will, at its discretion and according to the terms as set forth within, replace or repair any materials which fail under normal use and service and do not exhibit any signs of improper maintenance, misuse, accident, alteration, weather damage, tampering, or use for any other than the intended purpose. Determination of failure is the responsibility of Nuvair, which will work together with the customer to adequately address warranty issues. When any materials are repaired or replaced during the warranty period, they are warranted only for the remainder of the original warranty period. This warranty shall be void and Nuvair shall have no responsibility to repair or replace damaged materials resulting directly or indirectly from the use of repair or replacement parts not approved by Nuvair.

### Terms:

Nuvair warrants the Pro He to be free from defects in material and workmanship for a period of twelve (12) months from date of purchase. The warranty covers parts and labor.

A warranty registration card, supplied with system documentation, must be filled out and submitted to Nuvair for the warranty to be registered. If the warranty registration card is not received within ten (10) days of purchase, the warranty will begin with the date of manufacture by Nuvair.

### Maintenance Items:

Any materials which are consumed, or otherwise rendered not warrantable due to processes applied to them, are considered expendable and are not covered under the terms of this policy. This includes batteries.

### Return Policy:

Application for warranty service can be made by contacting Nuvair during regular business hours and requesting a Return Material Authorization number. Materials that are found to be defective must be shipped, freight pre-paid, to the Nuvair office in Oxnard, California. Upon inspection and determination of failure, Nuvair shall exercise its options under the terms of this policy. Warranty serviced materials will be returned to the customer via Nuvair's preferred shipping method, at Nuvair's expense. Any expedited return shipping arrangements to be made at customer's expense must be specified in advance.

### Limitation of Warranty and Liability:

Repair, replacement or refund in the manner and within the time provided shall constitute Nuvair's sole liability and the Purchaser's exclusive remedy resulting from any nonconformity or defect. Nuvair shall not in any event be liable for any damages, whether based on contract, warranty, negligence, strict liability or otherwise, including without limitation any consequential, incidental or special damages, arising with respect to the equipment or its failure to operate, even if Nuvair has been advised of the possibility thereof. Nuvair makes no other warranty or representation of any kind, except that of title, and all other warranties, express or implied, including warranties of merchantability and fitness for a particular purpose, are hereby expressly disclaimed. No salesman or other representative of Nuvair has authority to make any warranties.



**Notes:**

**Notes:**

**Notes:**



Nuvair  
Phone +1 805 815 4044  
Fax +1 805 486 0900  
1600 Beacon Place  
Oxnard, CA 93033  
USA  
[info@nuvair.com](mailto:info@nuvair.com)  
[www.nuvair.com](http://www.nuvair.com)