



User Manual

Pro Trimix AlarmTM

Helium & Oxygen Gas Analyzer

Rev. 08.22

If you have any questions on this equipment please contact Technical Support at:

Nuvair
1600 Beacon Place
Oxnard, CA 93033

Phone: 805-815-4044
FAX: 805-486-0900
Email: info@nuvair.com

Hours: Monday through Friday
8:00 AM to 5:00 PM PST USA

Warning

This Operation Manual contains important safety information and should always be available to those personnel operating this equipment. Read, understand, and retain all instructions before operating this equipment to prevent equipment damage, injury, or death.

Every effort was made to ensure the accuracy of the information contained within this manual; however, we retain the right to modify its contents without notice. **If you have problems or questions after reading this manual, stop and call Nuvair for information.**

Warning

Never expose gas sensors to pressure or you may cause damage and/or false readings. Damaged sensors will not provide accurate gas analysis. Most gas analyzers can be used to analyze a regulated gas sample flow, the contents of a gas cylinder, or the flow from a regulator. The flow rate of gas must equal 1-5 L/min. To produce this flow, a Flow Restrictor and Regulator may be required. A faulty Flow Restrictor can lead to a false analyzer reading. Flow Restrictors should be regularly tested with a Flow Meter. Inaccurate gas analysis can lead to serious personal injury or death.

Table of Contents

1.0 Introduction	4
2.0 System Description	5
2.1 Controls	7
2.2 Display	7
2.3 Alarm	7
2.4 Sensor	7
2.5 Batteries	7
2.6 Flow Adapter Cap	8
3.0 Calibration	8
4.0 Operation.....	9
4.1 Sample Flow Method	10
5.0 Over View of Programming Procedures	10
6.0 Programming Procedures Helium Analyzer	11
6.1 Alarm Setting	12
6.2 Full Scale Value Setting	12
6.3 Auto Off Delay Time Setting	12
7.0 Helium Threshold Alarms.....	13
8.0 Helium Powering Off	13
9.0 Helium Factory Reset	13
10.0 Programming Procedures Oxygen Analyzer	14
10.1 Alarm Setting	15
10.2 Full Scale Value Setting	15
10.3 Oxygen Calibration Value (OC2)	16
11.0 Oxygen Threshold Alarms	16
12.0 Oxygen Analyzer Powering On and Warming Up	17
12.1 Oxygen Powering Off	17
13.0 Oxygen Factory Reset	17
14.0 Maintenance.....	18
14.1 Analyzer Care	18
14.2 Battery Replacement	19
14.3 Sensor Replacement	20
14.4 Handling Sensor	20
15.0 Spares and Accessories	21
15.1 Sensors.....	21
15.2 Calibration Equipment	21
15.3 Charger for 110/230V Analyzer.....	21
15.4 Flow Restrictors and Regulators	22
16.0 Troubleshooting.....	22
17.0 Relay Output Schematics.....	23
Appendix	24
Analyzer Sensors Specifications.....	24
Warranty	25
Helium and Air Chart	26

1.0 Introduction

This manual will assist you in the proper set-up, operation and maintenance of the Pro Trimix Helium & Oxygen Analyzer. Be sure to read the entire manual.

Throughout this manual we will use certain words to call your attention to conditions, practices or techniques that may directly affect your safety. Pay particular attention to information introduced by the following signal words:

Danger

Indicates an imminently hazardous situation, which if not avoided, will result in serious personal injury or death.

Warning

Indicates a potentially hazardous situation, which if not avoided, could result in serious personal injury or death.

Caution

Indicates a potentially hazardous situation, which if not avoided, may result in minor or moderate injury. It may also be used to alert against unsafe practices.

Notice

Notifies people of installation, operation or maintenance information which is important but not hazard-related.

Warnings Graphics Defined:



Gas Inhalation



Skin damage

Abbreviations commonly used in this manual:

P.S.I. Pounds Per Square Inch
 L.P. Low Pressure
 O₂ Oxygen
 He Helium

H.P.
 P.P.M
 L/min
 O₂%

High Pressure
 Parts Per Million
 Liters Per Minute
 Oxygen Percentage of Gas

2.0 System Description

The Pro Trimix Helium & Oxygen Analyzer measures Helium (He) and Oxygen (O₂) levels in gasses in the range of 0 to 100% of volume with a .1% resolution. It can be used to measure the He and O₂ content in all breathing gas mixes. The Analyzer is designed to verify Helium & Oxygen concentration in stored gas cylinders, as well as monitor a continuous flow of gas. The Analyzer is compatible with outdoor and marine environments.



! Danger

Helium is a colorless, odorless, tasteless gas that will not support life. Exposure to Helium can lead to unconsciousness and death.

The Analyzer is powered by a rechargeable Lithium Polymer battery. A 110/230V charger is supplied with the unit. Also included are two internally mounted sensors with audible & visual alarms.

The Analyzer uses a Flow Adapter Cap and Flexible tubing to deliver sample gas to the Sensors. Pressurized gases must be regulated to avoid damage to the analyzer. Use of this Analyzer in a hyperbaric chamber will void the owner's warranty.

The Analyzer is self calibrating and ready for use after powering on. Certified calibration gas should be used periodically to confirm the accuracy of the analyzer and that the sensor and electronics are working properly.



! Warning

This analyzer is designed for use at atmospheric pressures only. It is not designed for exposure in a hyperbaric chamber. Use of this analyzer in a hyperbaric chamber will result in incorrect readings and may damage the unit.

! Warning

Although the Analyzer has been designed to handle rugged environments, careless handling or abuse may result in damage to the unit and this may result in inaccurate gas analysis. Inaccurate gas analysis can lead to serious personal injury or death.

! Notice

High Pressure Gas directed at the Analyzer may damage the sensors.

! Warning

The Analyzer is provided in a water-resistant case. However, the electronics inside are not water resistant. The Lithium Polymer battery can heat up and cause a fire if exposed to water. Do not allow water to enter the Analyzer case.

2.0 Description Continued



Helium Display

Oxygen Display

Gas Supply Hose



AC Adapter
(This is the only charger that is approved for use with this analyzer)



Helium Relay Out Option

Gas Supply Inlet

Oxygen Relay Out Option

Charger Port

2.1. Controls

The Control buttons for each gas are the same and are referenced throughout the instructions as “On/Off”, “Prog”, and “Adjust”. Sections 6.0-9.0 of the manual are instructions for the He analyzer. Sections 10.0-13.0 of the manual are instructions for the O₂ analyzer.



2.2. Display

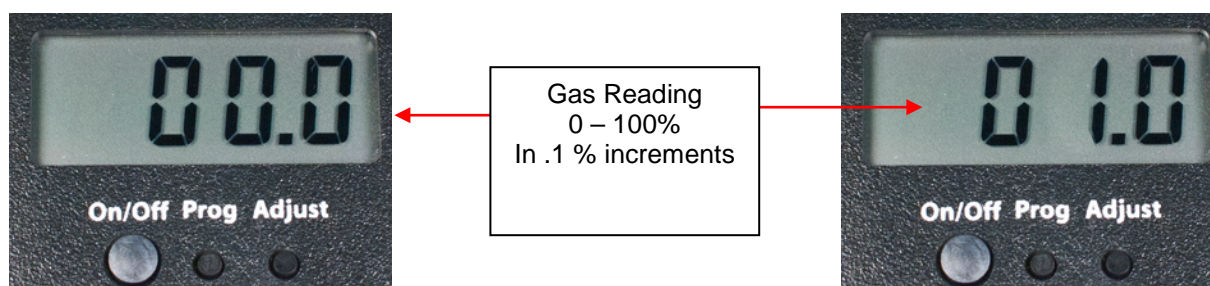

2.3. Alarm

The Analyzer includes audible and visual alarms that are activated according to user programmed settings. The alarm will clear when the concentration of gas returns to within the set points.

2.4. Sensors

The Analyzer uses a “Thermal Conductive” Helium sensor to measure He content and an “Electrochemical” Oxygen Sensor to measure O₂ content. The Sensors are disposable and user-replaceable, with a life expectancy of 60 + months for the Helium and up to 24 months for the Oxygen depending on usage. The sensors are designed for use at atmospheric pressure (0 P.S.I.). The gas mixture to be analyzed must be regulated accordingly, and any potential for pressure or vacuum must be avoided.

2.5. Battery

The “Pro Trimix Alarm” uses a rechargeable Lithium Polymer battery. Only use the supplied Nuvair “110/230V” charger. A fully charged battery should last up to 24 hours. Recharge takes about 4 hours. See section 15.3 for complete charging instructions.

DO NOT LEAVE UNIT UNATTENDED WHILE CHARGING and UNPLUG ONCE CHARGED.

2.6. Flow Adapter Cap

The Analyzer includes a Flow Adapter Cap with flexible tubing and flow orifice. It attaches to the gas supply inlet and is sealed by an o-ring. It is used to direct the gas sample flow to the Sensors.



Flow to the sensor must be restricted to 0.5 – 2.0 L/min. Increased flow will create faulty readings. Flow restrictors to accomplish this task may be purchased separately. They are described in section 15.4.

3.0 Calibration

⚠ Warning

Analyzer calibration must be verified on a weekly basis. Improper calibration may result in an incorrect reading, exposing the user to dangerous levels of Helium or incorrect breathing gas mixtures. Exposure to incorrect breathing gas mixtures can lead to unconsciousness and death.

⚠ Warning

Calibration must be done using a calibration gas. The calibration gas must be regulated and supplied at atmospheric pressure (0 P.S.I.). Use of gas at higher pressures may result in incorrect readings and may damage the Analyzer. Incorrect readings may expose the user to high levels of Helium or Oxygen, resulting in personal injury or death.

⚠ Warning

Checking Calibration or use of the Analyzer with a low battery may result in inaccurate readings. Inaccurate gas analysis can lead to serious personal injury or death.

⚠ Notice

If the Analyzer has been exposed to a recent extreme change in ambient temperature, allow it to stabilize for two minutes before checking calibration.

⚠ Warning

During the warm up and calibration, if the oxygen percentage of the mixed gas flow is different from the value of calibration set in the instrument, a failed calibration is obtained and a wrong analysis value will be displayed.

Verify calibration on a weekly basis. Breathing gas applications require the use of a certified He calibration gas and flow rate of 0.5 - 2.0 L/min. Certified test gas may be purchased separately. See section 15.2

To assure the greatest accuracy, the calibration gas concentration should be similar to the expected concentration in the gas being measured.

4.0 Operation

Prior to each Analyzer use:

- 1) **Remove the Flow Adapter Cap from the Gas Supply Inlet.** Ensure that the Analyzer Sensors are exposed to ambient air.
- 2) Turn Pro He on by holding the “On/Off” button for more than 3 seconds, until display shows “On”. The unit will then display the current firmware version, and then the current gas level sensed by the analyzer sensor. Repeat the same procedure with the Pro O₂ analyzer. Values displayed should reflect ambient air percentages (0% He, 21% O₂ at sea level).

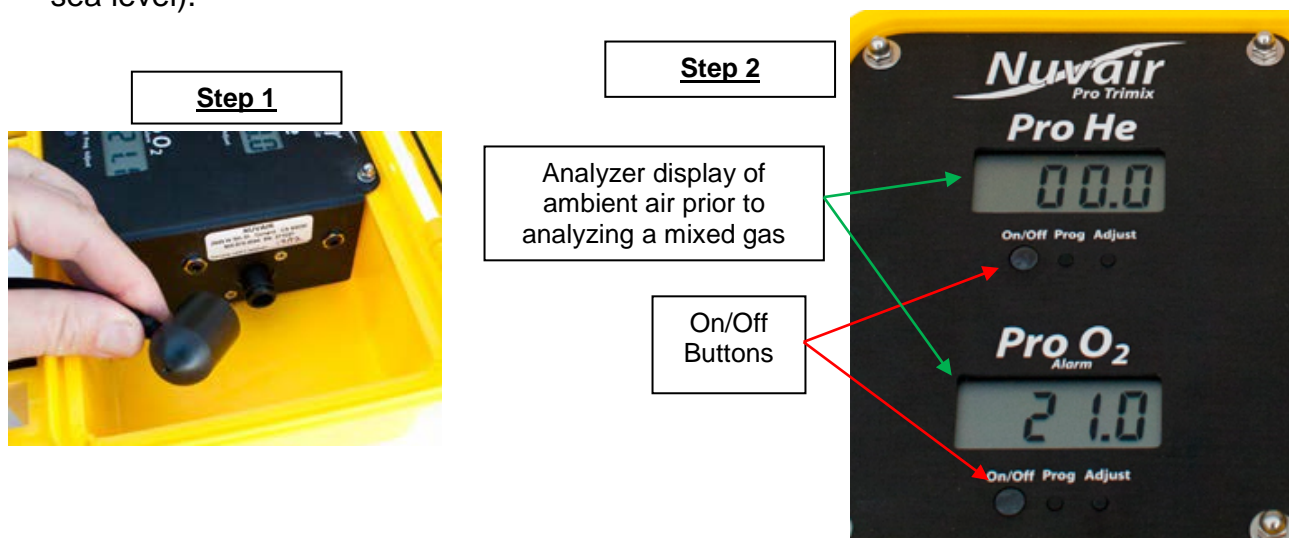

- 3) Cycle through the current settings of the analyzer:
 - A. Hold down the “Prog” button for 2 seconds then use the “On/Off” button to cycle through the settings.
 - B. Adjust Alarm values at this time if needed.

(Detailed instructions for performing items **A** & **B** are found in the respective sections later in this manual.)
- 4) Confirm calibration of Analyzer using “Calibrated Test Gas”.

Warning

Gas, even under moderate pressures, can cause extreme bodily harm. Never allow any gas stream to be directed at any part of your body.

Warning

Never expose the sensor to pressures above atmospheric pressure (0 P.S.I.) or you may cause damage to the sensor and/or receive false readings. Damaged Sensors will not provide accurate gas analysis. Inaccurate gas analysis can lead to serious personal injury or death.

The Pro Trimix Alarm can be used to analyze a regulated gas sample flow, the contents of a gas cylinder, or the flow from a regulator:

- When analyzing a gas, the flow rate must equal 0.5 – 2.0 L/min at atmospheric pressure (0 psi). To produce this flow, a flow restrictor and/or regulator may be required. Contact Nuair if you need assistance.

4.1. Sample Flow Method of Checking Calibration (Preferred):

(Ensure that the Flow Adapter is disconnected and Analyzer Displays are stabilized before beginning)

Step 1: Remove Flow Adapter Cap from Gas Supply Inlet, disconnect Flexible Tubing from the Cap



Step 2: Attach Flexible Tubing to Gas Sample Flow of 0.5 – 2.0 L/min. Verify that gas is flowing through the tubing, and then attach the Flow Adapter Cap



Step 3: Verify that Gas is Flowing through Holes in Flow Adapter Cap, then attach cap to Gas Supply Inlet



Step 4: Allow Display Reading to Stabilize

Step 5: Record Reading while Gas is Flowing



Certified test gas (P/N 101618) for confirming calibration can be purchased separately. See section 15.2.

Testing Gas must contain a known amount of Helium for calibration test to succeed.

Do NOT use a gas mix containing Acetylene, Ammonia, Argon, CO², Ethane, Ethylene, Freon, Hydrogen, Methane, Neon, Propane, etc.

Flow Restrictor/
Regulator
Assembly



P/N P101618
Nuair Calibration
Gas Specs:
18% O²
50% He
32 % N (Nitrogen)

5.0 Overview of Programming Procedures

The Pro Trimix Alarm analyzer is two analyzers in one case sharing the same sample gas flow. Each of the analyzers has independent programming features available for minimum and maximum gas percentage alarms. Section 6.0 describes the programming procedures for the Helium analyzer and section 10.0 describes the programming procedures for the Oxygen analyzer. Each analyzer has independent displays and controls within the case. It is important to follow the directions of the related analyzer as the analyzers operate differently.

Each of the Analyzers can be reset to factory default settings should the user be concerned with the programming procedures not being set properly. Each of the Analyzers will have to be reset individually by following the procedures outlined in these instructions. It is important to note that each analyzer is independently and separately programmed. Therefore, resets must be done separately.

6.0 Helium Analyzer Programming Procedures

Keep the “Prog” button pressed for more than two seconds and then release the button. “Pr” should display for two seconds and then the display will change to AL 1 and alternate with the 3 digit set value.

It is possible to program:

- **AL 1** Low alarm point expressed in Percent (%) of Helium concentration
- **AL 2** High alarm point expressed in Percent (%) of Helium concentration
- **FSC** Full Scale Value expressed in Percent (%) of Helium concentration corresponding to the current at the analog output (0%=4mA, 100%=20mA).
- **tOn** Time on value- This is the time the analyzer will stay on before auto powering off.

At the end of the programming procedure the display will show “End” and the instrument will display the Helium content in the gas mix.

Below are the actual screen views of each of the modes.



Program

Alarm 1

Alarm 2



Full Scale Value

Auto Time Off

End

6.1. Setting Helium Alarm “AL1” (Low He%) & “AL2” (High He%)

- 1.) Press the “Prog” button for more than two seconds and then release the button.
On the display will appear “Pr” for two seconds, then “AL 1” for one second. Then the display will alternate “AL 1” and the current value of “AL 1” (low He%) setting. (Default is 100%. However, if either alarm is set at 100% the alarm will be excluded. In order for the alarm to function, both alarm points must be set below 100%).
- 2.) The blinking digit shows the cursor position.
- 3.) Press the “Prog” button to increase the value (from 0 to 9)
- 4.) Press the “Adjust” button to move the cursor to the next digit, the “Adjust” button will be used to cycle through the rest of the digits.
- 5.) To complete your entry and save “AL1” (low He %) value, press the “On/Off” button. The “AL 2” (high He%) programming view will then be displayed.
- 6.) Repeat steps 3 through 5 to modify and save the “AL 2” (high He%) setting if desired, or leave at 100% to exclude alarm.
- 7.) Once programming of “AL 2” is complete you will be in the “FSC” Value Screen and ready for programming this value. To jump to the end continue to press the “On/Off” button until the end screen appears.

6.2. Helium Full Scale Value Setting (FSC)

Once the alarms have been set, the Pro He Analyzer displays the “FSC” view so that the analog full scale value may be changed. It is not necessary to modify this value which is factory set at 100%. This is the Helium concentration which corresponds to a 20mA current at the analog output. The current will be 4mA at 0% Helium concentration. This value can be changed in the same manner as the Alarm settings:

- 1.) Press the “Prog” button for more than two seconds and then release the button.
On the display will appear “Pr” for two seconds, then “AL 1” will appear. Press the On/Off button to cycle through the Alarm settings until you reach the “FSC” view. The “FSC” screen and a 3 digit value will alternate for a few seconds and the Pro He Analyzer will be ready for adjusting the “FSC” Value.
- 2.) The blinking digit shows the cursor position.
- 3.) Press the “Prog” button to increase the value (from 0 to 9) (0-19 on the third value)
- 4.) Press the “Adjust” button to move the cursor to the next digit, the “Adjust” button will be used to cycle through the rest of the digits.
- 5.) To complete your entry and save the FSC value, press the “On/Off” button. The display will then move to the to “tOn” programming view.

6.3. Helium Auto Switch Off Delay Time (tOn)

In this setting it is possible to change the auto off delay time of the Analyzer. The default setting is 180 seconds. For customer convenience the analyzer has been modified for a time delay of 600 seconds prior to shipping. This value is changed by using the same procedure as the Alarm settings. Follow the procedure above in section 6.1 steps 3 & 4. This setting can be adjusted from 0 to 1999 seconds. To keep the instrument from automatically powering off, the Analyzer time should be set to “000” seconds. To complete your entry and move to the end screen press the power on/off button when programming is complete.

Warning

The analyzer will shut off after the set time value is reached. If analyzer is being used for continuous blending, set the value to “000” to prevent the analyzer from shutting off automatically. If the analyzer is turned off, inaccurate gas mixture may take place and lead to a death. Always analyze mixed gas before use.

7.0. Helium Threshold Alarms

The Pro He Alarm Analyzer will alarm if the measured value of the analyzed gas goes beyond an alarm set point (“AL1” [Low He%] or “AL2” [High He%]) if the alarm is set to function. Should the instrument go into alarm mode, it will activate the (optional) relay output (open collector max 100mA) and the internal buzzer. The display will show the trespassed alarm and the actual measured value. To stop the audible alarm, press any button. In this event the Pro He Alarm Analyzer will remain in alarm mode until the measured value reads between the “AL1” and “AL2” set points. The relay output is typically used to shut down the compressor. NuVair can supply the necessary components to adapt your compressor to the relay, or provide them at the time of install on a new compressor.

8.0. Helium Powering Off

Hold down the On/Off button for a couple of seconds. The Analyzer will display “OFF” and then go blank.



9.0. Helium Factory Reset

If it becomes necessary to reset the Pro He Analyzer to the factory settings, first power on the Analyzer then pressing the “On/Off” and “Adjust” buttons at the same time and hold them for a few seconds. On the display will appear “res” and the instrument will go to the reading page.

Warning

After reset, the instrument will delete all the alarms settings and the Auto Off time value. Before using the instrument after a reset, it may be necessary to reprogram the alarm values and the Auto Off value. Calibration with a certified test gas must be performed immediately after a reset.

10.0 Oxygen Analyzer Programming Procedures

Keep the “Prog” button pressed for more than two seconds and then release the button. “Pr” should display for two seconds and then the display will change to AL 1 and alternate with the 3 digit set value.

It is possible to program:

- **AL 1** Minimum alarm point expressed in Percent (%) of Oxygen concentration
- **AL 2** Maximum alarm point expressed in Percent (%) of Oxygen concentration
- **FSC** Full Scale Value expressed in Percent (%) of Oxygen concentration corresponding to the current at the analog output. 20mA always correspond to 100 % oxygen concentration.
- **O2c** Oxygen sensor calibration point

At the end of the programming procedure the display will show “End” and the instrument will display the oxygen content of the gas mix.

Below are actual screen views of each of the modes.



Program



First Alarm



Second Alarm



Full Scale Value



Oxygen Sensor
Calibration



21% reading

10.1. Oxygen Alarm Setting (AL 1 & AI 2)

- 1.) Press the “Prog” button for more than two seconds and then release the button.
On the display will appear “Pr” for two seconds, then “AL1” will appear and be ready for changing the value of the alarm point for Low O₂%. After a second the display will show the value of “AL1” O₂% current setting. (0% default)
- 2.) The blinking digit shows the cursor position.
- 3.) Press the “Prog” button to increase the value (from 0 to 9)
- 4.) Press the “Adjust” button to move the cursor to the next digit, the “Adjust” button will be used to cycle through the rest of the digits.
- 5.) To complete your entry and save the O₂% value, press the “On/Off” button. The “AL 2” programming view will then be displayed.
- 6.) Repeat steps 3 through 5 to modify and save the “AL 2” (High O₂%) desired value (100% default).
- 7.) Once programming of “AL 2” is complete you will be in the “FSC” Value Screen and ready for programming this value. To jump to the end continue to press the “On/Off” button until the end screen appears.

10.2. Oxygen Full Scale Value Setting (FSC)

Once the alarms have been set the Pro O₂ Alarm Analyzer displays the “FSC” view so that the analog full scale value may be changed. It is not necessary to modify this value which is factory set at 100. This is the Oxygen concentration corresponding to 20 mA on the analog output. 4mA is the value at 0% of Oxygen. This value can be changed in the same manner as the Alarm settings:

- 1.) Press the “Prog” button for more than two seconds and then release the button.
On the display will appear “Pr” for two seconds, then “AL 1” will appear. Press the On/Off button to cycle through the Alarm settings until you reach the “FSC” view. The “FSC” screen and a 3 digit value will alternate for a few seconds and the Pro O₂ Alarm Analyzer will be ready for adjusting the “FSC” Value.
- 2.) The blinking digit shows the cursor position.
- 3.) Press the “Prog” button to increase the value (from 0 to 9)
- 4.) Press the “Adjust” button to move the cursor to the next digit, the “Adjust” button will be used to cycle through the rest of the digits.
- 5.) To complete your entry and save the FSC value, press the “On/Off” button. The “O2c” programming view will then be displayed. To continue past this view to the end, press the On/Off button until the “End” screen appears.

10.3. Oxygen Calibration Oxygen Value (O2c)

After the “FSC” is set, the Pro O₂ Alarm Analyzer displays the “O2c” setting. This is the current Oxygen calibration value. The default is 21%. **It is not necessary to modify this value.** The display then alternates between “O2c” and the current value (21% default).

- 1.) Press the “Prog” button for more than two seconds and then release the button. On the display will appear “Pr” for two seconds, then “AL 1” will appear. Use the On/Off button to cycle through the various settings until you reach the “O2c” screen. The 3 digit value will alternate with the “O2c” screen for a few seconds and the Pro O₂ Alarm Analyzer will be ready for adjusting the “O2c” Value.
- 2.) The blinking digit shows the cursor position.
- 3.) Press the “Pro” button to increase the value (from 0 to 9)
- 4.) Press the “Adjust” button to move the cursor to the next digit, the “Adjust” button will be used to cycle through the rest of the digits.
- 5.) To complete your entry and save the O2c value, press the “On/Off” button. At the end of the programming procedure the display will show “End”.

Warning

The default oxygen calibration value is 21%, which is what will be displayed after the Oxygen Analyzer is switched on. During the warm up, if the oxygen percentage of the gas flowing across the sensor is different than the calibration set in the instrument, a failed calibration is obtained and the wrong gas percentage will be displayed. Wrong oxygen analysis may lead to death.

Warning

The calibration value of the Pro O₂ Alarm is factory set at 21% and any adjustments to this value will change the analyzers ability to properly read the % of oxygen in a gas. An incorrect value in this parameter will give an incorrect reading of O₂ concentration and the instrument will not be accurate. If you modify this setting you must test the analyzer for accuracy with certified test gas. Do not modify this value. Wrong oxygen analysis may lead to death.

11.0. Oxygen Threshold Alarms

The Pro O₂ Alarm Analyzer will alarm if the measured value of the analyzed gas goes beyond an alarm set point (AL1 or AL2). Should the instrument go into alarm mode, it will activate the (optional) relay output (open collector max 100mA) and the internal buzzer. The display will show the trespassed alarm and the actual measured value. To stop the audible alarm, press any button. In this event, the Pro O₂ Alarm Analyzer will remain in alarm mode until the measured value reads between the AL1 and AL2 set points. The relay output is typically used to shut down the compressor. NuVair can supply the necessary components to adapt your compressor to the relay, or provide them at the time of install on a new compressor.

12.0 Oxygen Powering On and Warming Up

Press the On/Off button for more than 3 seconds, until the display shows “On”. Then the “Att” (wait) message will be displayed for about 4 seconds, followed by the sensor auto-calibration which lasts about 5 seconds. During this time the display will alternately show the messages “CAL” and “Att”.

Be sure that during this time the sensor is exposed to a gas mix with the same oxygen percentage as that programmed in the “O2c” parameter (see programming procedure). **By default the parameter is set at 21% which corresponds to the percentage of oxygen in ambient air.** In this example, make sure the ambient air that the sensor is exposed to contains 21% oxygen before turning on the analyzer. (Removing Flow Adapter Cap before startup will expose the sensor to ambient air.)

Warning

During startup and calibration, a false calibration can occur if the sensor is exposed to a gas with different percent Oxygen than that which is the programmed default. If a false calibration is obtained, the wrong Oxygen percentage will be displayed. Wrong oxygen analysis may lead to death.

12.1 Oxygen Powering Off

Hold down the On/Off button for a couple of seconds. The Analyzer will display “OFF” and then go blank.



13.0 Oxygen Factory Reset

If it becomes necessary to reset the Pro O₂ Analyzer to the factory settings, first power on the Analyzer the pressing the “On/Off” and “Adjust” buttons at the same time and hold them for a few seconds. On the display will appear “res” and the instrument will go to the reading page.

Warning

After reset, the instrument will delete all the alarms settings and any customization to the full scale value, and the Oxygen calibration will be lost, as the unit will be reset to factory settings. Before using the instrument, it will be necessary to reprogram the alarm values, the full scale value, and the Oxygen sensor calibration to the desired settings. Proper calibration should be achieved prior to using analyzer. Wrong Oxygen analysis may lead to death.

14.0. Maintenance

Warning

Analyzers immersed in liquid or stored in wet environments may not operate properly. This may result in incorrect readings. Incorrect gas analysis may result in personal injury or death. The Lithium Polymer battery may present a fire hazard if the battery gets wet.

Warning

Protect the analyzer from excessive shock and impact. Excessive shock and impact may result in incorrect readings. Incorrect gas analysis may result in personal injury or death.

Warning

Protect the analyzer from exposure to hyperbaric environments. Exposure to hyperbaric environments may result in incorrect readings. Incorrect gas analysis may result in personal injury or death.

14.1. Analyzer Care

- Do not clean Analyzer with anything other than a damp soft cloth.
- Do not immerse in liquid, leave unprotected outside, or store in a wet environment.
- Protect Analyzer from excessive shock and impact.
- Protect Analyzer from excessive exposure to sunlight and extreme temperatures.
- Do not use the Analyzer in a hyperbaric environment.

14.2. Battery Replacement

⚠ Notice

Be sure to dispose of spent or damaged Battery properly and according to local regulations.

The following instructions show the steps necessary to replace the Lithium Polymer battery used to power the Pro Trimix Alarm analyzer:



Step 1: Remove four Nuts and washers

Step 2: Rotate Analyzer Cover upside down with hand on panel

Step 3: Remove & Replace Old Battery

Step 4: Replace Analyzer Cover - Do Not Pinch Wires

Step 5: Reinstall Nuts and washers

Step 6: Charge battery

Step 7: Turn Analyzer On

Step 8: Perform Calibration Test

Remove four nuts and pull out aluminum panel. The Lithium Polymer battery is under this panel. Contact Nuvair for a replacement battery.

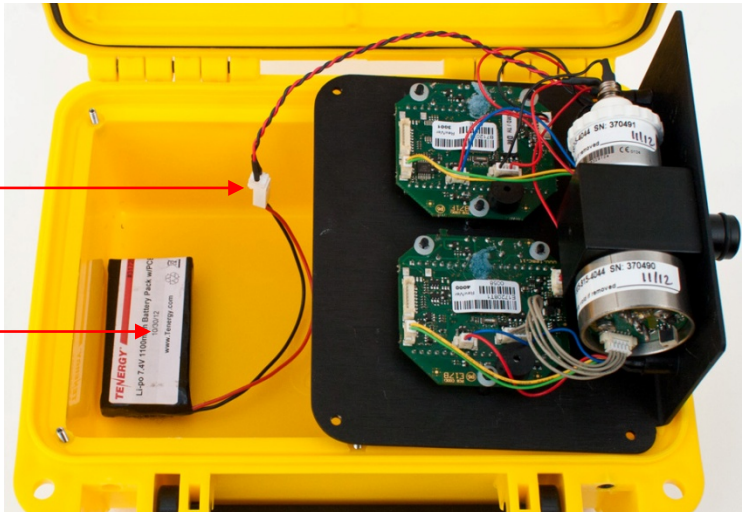

Disconnect Battery

Battery is held in place by Velcro

⚠ Warning

Replace sensor when either the Helium or Oxygen analyzer is unable to correctly analyze Supply gas. The use of an exhausted sensor may cause incorrect gas analysis. Incorrect gas analysis may lead to death. Contact NUVAIR for sensor replacement parts. Do not use any other sensor brands for replacement. Unauthorized sensors may not work properly in this analyzer and use of them will void all warranties.

14.3. Sensor Replacement

Take care not to damage sensor when replacing. Unplug sensor and rotate the sensor out of the threaded port the sensor is mounted in.



Helium Sensor
P/N 9511



Oxygen Sensor
P/N 9507

⚠ Caution

Be sure to dispose of spent or damaged Sensors properly, according to local regulations for solid state electronics.

14.4. Handling Sensors

Replacement Sensors are supplied in sealed bags. Normally Sensors do not present a health hazard. Dispose of Sensor properly or return for replacement. Sensors are made using Solid State technology and should be handled like similar electronics according to local regulations.

Electrolyte First Aid Procedures

- Ingestion - Drink a large volume of fresh water. Do not induce vomiting. Get immediate medical attention.
- Eye Contact - Flush eyes with clean, fresh water for at least 15 minutes and get medical help immediately.
- Skin Contact - Flush the affected area with clean, fresh water for at least 15 minutes and removed contaminated clothing. If stinging persists get medical attention.



⚠ Warning

Do not try to disassemble the sensor. Sealed unit contains caustic liquid (KOH) which may cause severe burns to skin and eyes. In case of contact, flush 15 minutes with water. For contact to eyes flush immediately with water and seek medical attention. If not properly treated, the eyes may have permanent damage.

15.0 Spares and Accessories

15.1. Sensors

Contact Nuair for replacement sensors Used in the Nuair Pro Trimix Alarm.



Helium Sensor
P/N 9511



Oxygen Sensor
P/N 9507

15.2. Calibration Equipment

Calibration check requires certified He calibration gas to be delivered at a specific flow rate and pressure.

A variety of calibration gas canisters are available from Nuair, with compatible Flow Restrictor/ Regulator assemblies to regulate the gas.

Do NOT use a gas mix containing Acetylene, Ammonia, Argon, CO², Ethane, Ethylene, Freon, Hydrogen, Methane, Neon, Propane, etc.

Flow Restrictor/
Regulator
Assembly

P/N P101618
Nuair Calibration
Gas Specs:
18% O²
50% He
32 % N (Nitrogen)



15.3. Authorized 110/230V Charger

VERY IMPORTANT: USE ONLY NUVAIR SUPPLIED MODEL: H00740003-XX-W1. USE OF ANY OTHER CHARGER COULD CAUSE A FIRE AND VOIDS WARRANTY.

Features:

- 110V-240V AC input for worldwide power support
- Constant charging current for faster charging
- Stabilized output, low ripple
- Safety Protection:
 - Over Voltage Protection
 - Short Circuit Protection
 - Output reverse input protection
- The charger will cut off automatically if battery is fully charged (1/10C) and indicated by LED

In charging mode **RED** LED
Battery Full **GREEN** LED



Specifications:
Input: AC 100-240V 50-60Hz
Output: DC 8.1V
Charging Current: 300mA

WARNING:

- Charge only Nuair 7.4V Li-ion rechargeable battery pack with this charger
- Don't expose the product to rain or humidity to prevent from electric shock
- It is normal for the product to get slightly warm when in use
- Keep out of reach of children
- Don't touch any part of the product during charging to prevent electric shock.

15.4. Flow Restrictors and Regulators

A variety of Flow Restrictors and Pressure Regulators for the Sample Flow Method are available from NuVair, all calibrated to produce a flow rate of 0.5 – 2.0 L/min with a Regulator output of 100 – 160 P.S.I.

Universal Flow Restrictors are used for most applications and are typically provided complete with Regulator.

When analyzing Scuba Cylinder gases, special Flow Restrictors can be used to obtain the sample gas directly from the BC inflator hose. A variety of BC Flow Restrictors are available to fit the different types of inflator hose QD fittings used.

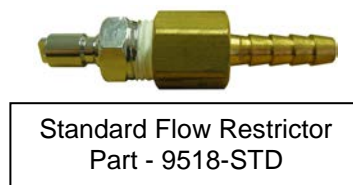
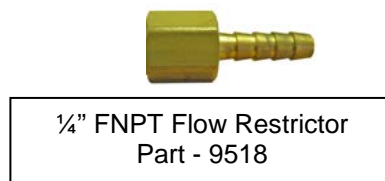
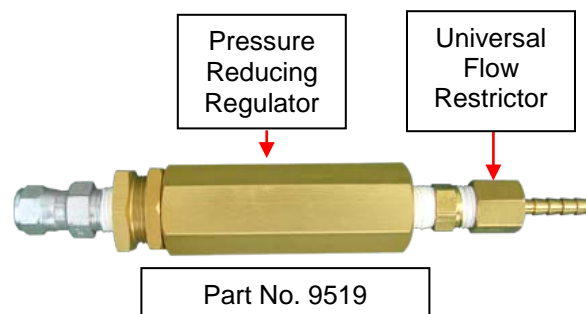

16.0 Troubleshooting

SYMPTOM	REASON	SOLUTION
Battery symbol	Low Battery	Change the battery
No display	Switched off Bad connection Low Battery	Switch on Check display/ battery connection Change the battery
Reading erratic	Pressure on sensor Radio transmission Sensor old or faulty Condensation on sensor.	Check flow Move unit away Change sensor Dry in air
Display segments missing	Display faulty	Return to dealer
Reading drifts	Rapid temperature change	Stabilize temperature & recalibrate

17.0 Relay Output Schematics

4-20mA Connections: The relay output uses a special “Mini Jack” plug that can be purchased separately from Nuvair. Insert the plug into the output jack. Connections diagram below for additional wiring.

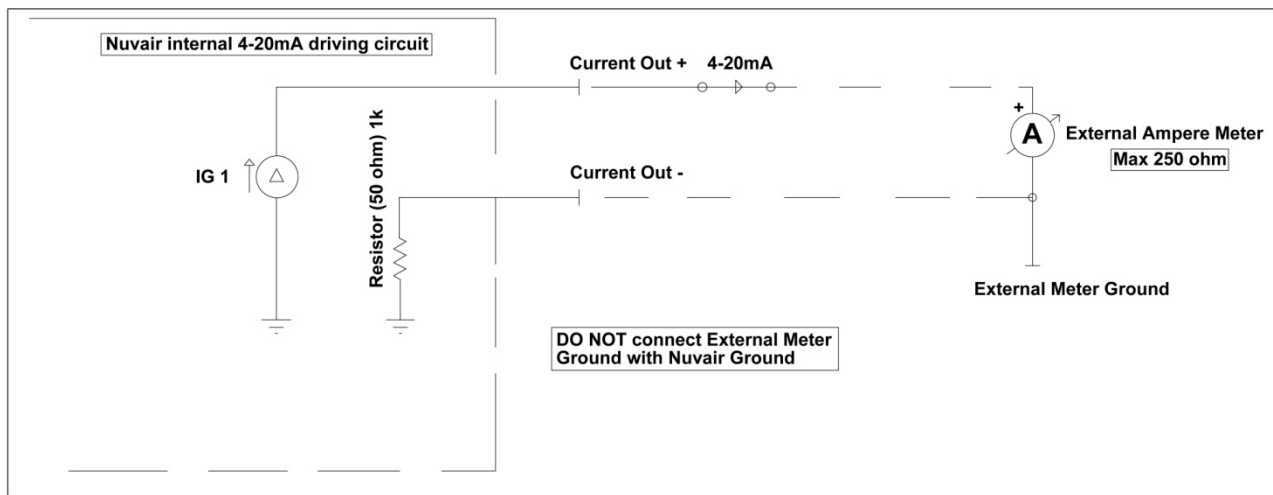

⚠ Warning

The plug should be inserted or removed when the instrument is switched off, or the instrument will automatically switch off.

Open Collector Connections:

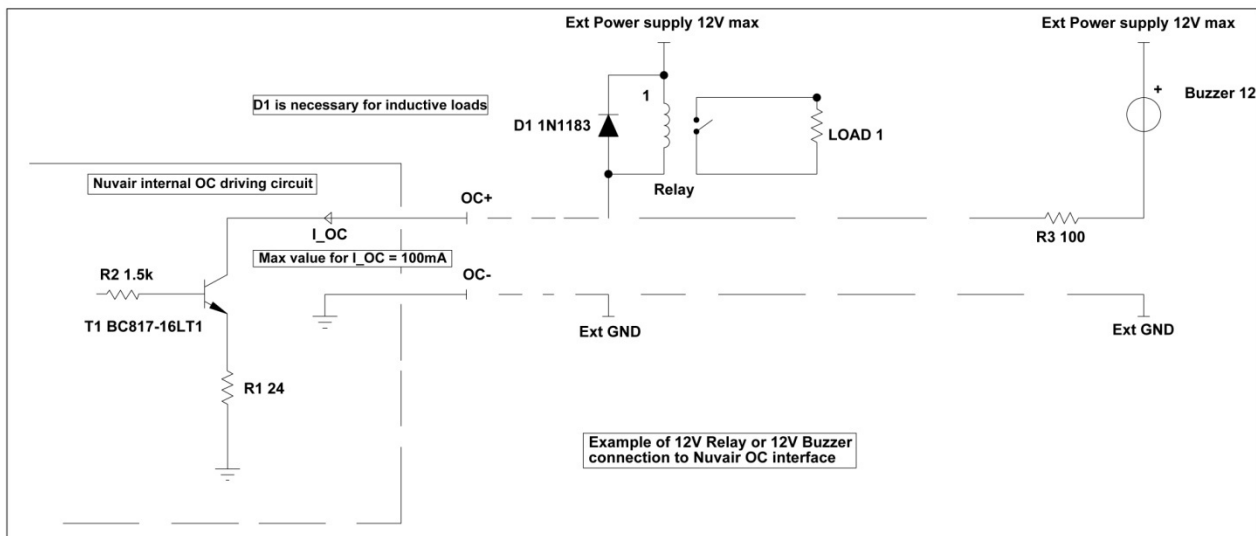

Appendix**Analyzer Specifications Helium Sensor (P/N 9511)**

Resolution:	0 – 100% Helium in air or nitrogen or oxygen
Alarm Set Point:	What ever % desired of He
Display Accuracy:	+/- 2%
Sensor Type:	Thermal Conductive Technology
Expected Sensor Life, Room Air:	5+ Years
Power:	Rechargeable Lithium Ion Battery 110/230v electric
Response Time:	Less than 10 Seconds to 90% of Final Value
Stabilization Time:	10 Minutes Max Accuracy
Operating Temperature:	41 to 104°F (5 to 40°C) Will work outside this range with decreased accuracy.
Storage Temperature:	5 to 122°F (-15 to 50°C)
Operating Pressure:	Not to Exceed 1 Atmosphere Absolute (0 P.S.I.)
Humidity:	0-90% Non Condensing. Don't allow moisture to build up on the sensing surface.
Warranty:	12 Months

Note: All specifications are at ambient / sea level, 77°F / 25°C and subject to change without notice

Analyzer Specifications Oxygen Sensor (P/N 9507)

Sensor Type:	Electrochemical (Galvanic)
Electrical Connector:	3.5 mm Molex Jack
Range:	0-100.0% Oxygen (0-1 ATA PPO ₂)
Display Accuracy:	+/- 0.1%
Expected Sensor Life, Room Air:	0-24 Months @ ambient air
Output Signal:	11+- 3 milliVolt @ dry ambient air 74°F (23°C)
Power:	Rechargeable Lithium Ion Battery 110/230v electric
Response Time:	Less Than 12 Seconds
Drift:	< 1% volume O ₂ / month @ air
Operating Temperature:	32-104°F (0-40°C)
Storage Temperature:	recommended: 41to 86°F (5 to 30°C) maximum: -4 to122°F (-20 to 50°C)
Pressure:	750 to 1250 hPa
Linearity Error:	= 2% @ 100% O ₂ applied for 5 min.
Zero Offset Voltage:	= 200 uV in 100% N ₂ , applied for 5 min.
Influence of Humidity:	-0.03% rel. O ₂ reading /%RH
Humidity:	up to 100% RH
Temperature Compensation:	NTC
Interferences:	according to DIN EN 12598 and ISO 7767
Material in contact media:	PA, PPS, PTFE, stainless steel
Warranty:	24 Months Prorated

In the interest of product improvement these design specifications may change without notice.

Note: All specifications are at ambient / sea level, 77°F / 25°C.

NUVAIR Pro Trimix™ Warranty

Nuvair extends a limited warranty, which warrants the Pro Trimix to be free from defects in materials and workmanship under normal use and service for a one year with the exception of the Oxygen Sensor. The Pro Trimix Oxygen Sensor is under warranty according to the pro-rated terms as set forth below. This warranty is non-transferable.

Nuvair will, at its discretion and according to the terms as set forth within, replace or repair any materials which fail under normal use and service and do not exhibit any signs of improper maintenance, misuse, accident, alteration, weather damage, tampering, or use for any other than the intended purpose. Determination of failure is the responsibility of Nuvair, which will work together with the customer to adequately address warranty issues. When any materials are repaired or replaced during the warranty period, they are warranted only for the remainder of the original warranty period. This warranty shall be void and Nuvair shall have no responsibility to repair or replace damaged materials resulting directly or indirectly from the use of repair or replacement parts not approved by Nuvair.

Pro-Rated Terms:

NUVAIR warrants the O₂ sensor to be free from defects in material and workmanship for a period of twenty-four (24) months from date of purchase. The warranty covers parts and labor and is prorated as follows:

- 0 – 12 Months Free Replacement
- 13 – 18 Months 50% Off Replacement
- 19 – 24 Months 25% Off Replacement

A warranty registration card, supplied with system documentation, must be filled out and submitted to Nuvair for the warranty to be registered. If the warranty registration card is not received within ten (10) days of purchase, the warranty will begin with the date of manufacture by Nuvair.

Maintenance Items:

Any materials which are consumed, or otherwise rendered not warrantable due to processes applied to them, are considered expendable and are not covered under the terms of this policy.

Return Policy:

Application for warranty service can be made by contacting Nuvair during regular business hours and requesting a Return Material Authorization number. Materials that are found to be defective must be shipped, freight pre-paid, to the Nuvair office in Oxnard, California. Upon inspection and determination of failure, Nuvair shall exercise its options under the terms of this policy. Warranty serviced materials will be returned to the customer via Nuvair's preferred shipping method, at Nuvair's expense. Any expedited return shipping arrangements to be made at customer's expense must be specified in advance.

Limitation of Warranty and Liability:

Repair, replacement or refund in the manner and within the time provided shall constitute Nuvair's sole liability and the Purchaser's exclusive remedy resulting from any nonconformity or defect. Nuvair shall not in any event be liable for any damages, whether based on contract, warranty, negligence, strict liability or otherwise, including without limitation any consequential, incidental or special damages, arising with respect to the equipment or its failure to operate, even if Nuvair has been advised of the possibility thereof. Nuvair makes no other warranty or representation of any kind, except that of title, and all other warranties, express or implied, including warranties of merchantability and fitness for a particular purpose, are hereby expressly disclaimed. No salesman or other representative of Nuvair has authority to make any warranties.

Helium and Oxygen Sample Test Chart

The Helium and Air chart contains a set of numbers for validating that Pro Trimix Alarm analyzer is working properly. The concept behind using the chart is that the user has a high and low Helium test gas available. We recommend: 90% Helium (balance Nitrogen), 10% Helium (balance Nitrogen), and certified breathing air 20.9% Oxygen. These gases should be contained in portable storage bottles with regulators and flow restrictors for delivery to the Analyzer. Gas delivery needs to be regulated down to 0.5 -2.0 liters per minute using flow restrictors.

In this procedure the Oxygen Analyzer is turned on first with calibrated breathing air gas flowing to the Analyzer. The Oxygen Analyzer will self calibrate to the known gas.

The second step is to turn on the Helium Analyzer and connect the 10% Helium Gas to the Analyzer. Open the gas and allow the Oxygen Analyzer to stabilize.

Note the Oxygen and Helium readings at this time. Using the chart look up the Helium Gas being used and confirm the Oxygen reading matches within 1 to 2% of the number stated on the chart.

Repeat the process with the 90% Helium gas and confirm the Oxygen percentage is within 1 to 2% of the Chart reading.

We recommend a High and Low Helium mix for doing this test and have provided this chart so that you can confirm proper analysis is being recorded by the analyzer.

It is very important that the Oxygen Analyzer is turned on and calibrated first to verify the analyzer is reading the correct content of Oxygen. This will help ensure the Helium test is accurate.

The Helium test gas should only contain Helium and Nitrogen. No other gases should be present in the mix.

If the Analyzer does not measure the Helium and Oxygen properly, we recommend you recalibrate the Oxygen Analyzer and do the test over again. If the Analyzer fails the test again, Contact Nuvair customer service to discuss the return of the Analyzer for testing and possible repair.

Helium & Air Chart

Percent Helium	Percent Oxygen	Percent Helium	Percent Oxygen	Percent Helium	Percent Oxygen	Percent Helium	Percent Oxygen
100	0.00	73	5.64	46	11.29	19	16.93
99	0.21	72	5.85	45	11.50	18	17.14
98	0.42	71	6.06	44	11.70	17	17.35
97	0.63	70	6.27	43	11.91	16	17.56
96	0.84	69	6.48	42	12.12	15	17.77
95	1.05	68	6.69	41	12.33	14	17.97
94	1.25	67	6.90	40	12.54	13	18.18
93	1.46	66	7.11	39	12.75	12	18.39
92	1.67	65	7.32	38	12.96	11	18.60
91	1.88	64	7.52	37	13.17	10	18.81
90	2.09	63	7.73	36	13.38	9	19.02
89	2.30	62	7.94	35	13.59	8	19.23
88	2.51	61	8.15	34	13.79	7	19.44
87	2.72	60	8.36	33	14.00	6	19.65
86	2.93	59	8.57	32	14.21	5	19.86
85	3.14	58	8.78	31	14.42	4	20.06
84	3.34	57	8.99	30	14.63	3	20.27
83	3.55	56	9.20	29	14.84	2	20.48
82	3.76	55	9.41	28	15.05	1	20.69
81	3.97	54	9.61	27	15.26		
80	4.18	53	9.82	26	15.47		
79	4.39	52	10.03	25	15.68		
78	4.60	51	10.24	24	15.88		
77	4.81	50	10.45	23	16.09		
76	5.02	49	10.66	22	16.30		
75	5.23	48	10.87	21	16.51		
74	5.43	47	11.08	20	16.72		



Nuvair™
Phone (805) 815-4044
Fax (805) 486-0900
1600 Beacon Place
Oxnard, CA 93033 USA
Email : info@nuvair.com
Web : www.nuvair.com