



Operation Manual

Voyager IVTM
Commercial

Nitrox System

Rev. 8.20

If you have any questions on this equipment please contact technical support at:

Nuvair
1600 Beacon Place
Oxnard, CA 93033

Phone: 1-805-815-4044
FAX: 1-805-486-0900
Email: info@nuvair.com

Hours: Monday through Friday
8:00 AM to 5:00 PM PST USA

If you lose this manual, you can download the latest version at www.nuvair.com.

Warning

This operation manual contains important safety information and should always be available to those personnel operating this equipment. Read, understand, and retain all instructions before operating this equipment to prevent injury or equipment damage.

Every effort was made to ensure the accuracy of the information contained within. Nuvair, however, retains the right to modify its contents without notice. If you have problems or questions after reading the manual, stop and call Nuvair at 1-805-815-4044 for information.

Table of Contents

Introduction

1.0 Introduction 4
 2.0 Safety Warnings and Warning Graphics Defined..... 5
 3.0 Safety and Operation Precautions 7
 4.0 Legal Precautions 8
 5.0 Theory of Operation 9
 6.0 Low Pressure Air Compressor Technical Data 10
 7.0 High Pressure Compressor Technical Data 11
 8.0 System Components 12
 9.0 Nitrox System Specifications 13
 10.0 Nitrox Voyager IV System Component Identification..... 14
 11.0 Options for the Voyager IV 16
 12.0 System Drawing/Schematic 17
 13.0 System Flow Chart 18

Setup, Operation, and Maintenance

14.0 Installing the Voyager IV Nitrox System 19
 14.1 Precautions 19
 14.2 Attaching Nitrogen Discharge Hose (Optional) 19
 14.3 Electrical Power Connection 20
 14.4 Check Compressor Lubricant Levels 21
 14.5 Control Panel Identification..... 21
 15.0 Pre-Operation Instructions 22
 15.1 Oxygen Analyzer Calibration..... 22
 16.0 Producing nitrox 24
 16.1 Flow to Membrane and Setting Proper Pressure..... 24
 16.2 Final Adjustments Before Pumping Nitrox 24
 16.3 Pumping Nitrox 26
 16.4 Pumping Air 28
 16.5 Shutting Down 28
 17.0 Nitrox Operational Notes 29
 17.1 Correlation of Feed Air Pressure to Oxygen Content 29
 17.2 Hot Fills 29
 18.0 Maintenance 30
 18.1 Daily Maintenance 30
 18.2 Routine Maintenance 31
 18.3 Compressor lubricant 32
 18.4 L.P. Feed Air Filtration and Bowls..... 34
 18.5 L.P. Filtration Inspection 34
 18.6 Changing L.P. Filtration Elements 35
 18.7 H.P. Compressor Filtration 36
 19.0 Spare Parts List 37
 20.0 Service Record Log 38
 21.0 Appendix 39
 21.1 Supply and Breathing Air Specifications 39
 21.2 Filter Element Life Factors 39
 Material Safety Data Sheets 40
 Owner's Warranty Responsibilities 43
 Warranty 44
 Additional Record of Changes 45

Separate Manuals Included:

- Nuvair Pro O₂™ Oxygen Analyzer Operation Manual
- Rotair RVK 8-20 Low Pressure Compressor Manual
- Coltri MCH-30 High Pressure Compressor Manual

1.0 Introduction

Nuvair has taken extreme care in providing you with the information you will need to operate this system. However, it is up to you to carefully read this manual and make the appropriate decisions about system safety.

This manual will assist you in the proper set-up, operation and maintenance of the Nuvair Voyager IV™ nitrox system. Be sure to read the entire manual.

Throughout this manual we will use certain words and symbols to call your attention to conditions, practices, and / or techniques that may directly affect your safety. Pay particular attention to information introduced by the following signal words:

Danger

Indicates an imminently hazardous situation, which if not avoided, will result in serious personal injury or death.

Warning

Indicates a potentially hazardous situation, which if not avoided, could result in serious personal injury or death.

Caution

Indicates a potentially hazardous situation, which if not avoided, may result in minor or moderate injury. It may also be used to alert against unsafe practices.

Notice

Notifies people of installation, operation or maintenance information which is important but not hazard-related.

2.0 Safety Warnings

 **Warning**

This equipment is used to provide breathing gas for the purpose of underwater life support. Read this manual in its entirety. Failure to heed the warnings and cautions contained in this document may result in severe injury or death.

 **Warning**

The equipment you will be using to manufacture nitrox (oxygen rich air) will expose you to both low and high-pressure gas. Gas, even under moderate pressures, can cause extreme bodily harm. Never allow any gas stream to be directed at any part of your body.

 **Warning**

Any pressurized hose can cause extreme harm if it comes loose or separates from its restraint (or termination) while under pressure and strikes any part of your body. Use appropriate care in making and handling all gas connections.

 **Danger**

Pure nitrogen is a colorless, odorless, tasteless gas that will not support life. Breathing gas mixtures containing more than 84% nitrogen at surface pressures will lead to unconsciousness and may cause death.

 **Warning**

The nitrogen discharge from the membrane system must be vented to the exterior of any closed building, boat, or similar enclosed space. Breathing gas mixtures containing more than 84% nitrogen at surface pressure will lead to unconsciousness and may cause death.

 **Warning**

Do not use any form of mineral oil or synthetic lubricant not rated for nitrox in any compressor in this system. Use only the recommended nitrox compressor lubricant. Never mix the nitrox compressor lubricant with other lubricants. Remove all existing lubricant and replace with the proper nitrox compressor lubricant prior to installing the membrane system. The use of improper lubricants can lead to fire or explosions, which may cause serious personal injury or death.

 **Warning**

Do not use this system to produce nitrox mixtures containing more than 40% oxygen. Pumping nitrox mixtures with higher concentrations of oxygen may lead to fires or explosions, which can cause serious personal injury or death.

⚠ Warning

The use of enriched air nitrox does not eliminate the risk of decompression sickness (DCS) in diving. Decompression sickness can lead to permanent disability or death.



⚠ Warning

Do not pump nitrox mixtures at pressures above the H.P. compressor manufacturer's rating, and never above 3600 P.S.I. (250 bar). The system is not rated for pressures above 3600 P.S.I. (250 bar). Higher pressures may lead to explosions which may cause serious personal injury or death.

⚠ Caution

Ambient room temperature should never exceed 104° F (40° C) during operation of the nitrox system. Operation at higher temperatures may lead to system damage and malfunction. A damaged membrane will not produce the correct nitrox mixture which can lead to severe personal injury if the gas is used for diving purposes without proper analysis.

Warnings Graphics Defined:



Moving belts



Electrocution

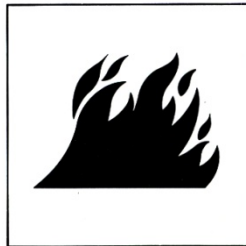

Fire

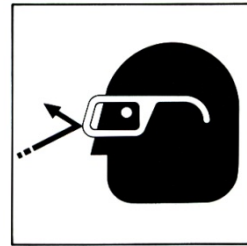

Eye protection

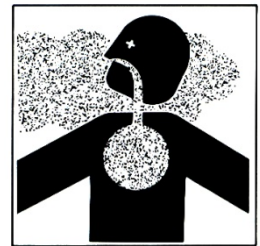

Gas inhalation



Skin damage

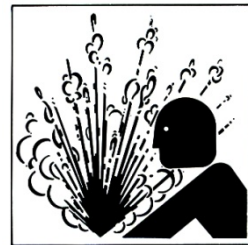

Explosion



Explosion



Electrocution



Machinery

Abbreviations commonly used in this manual:

P.S.I. Pounds Per Square Inch
 H.P. High Pressure
 L.P. Low Pressure
 O₂ Oxygen
 CO Carbon Monoxide
 CO₂ Carbon Dioxide
 N Nitrogen

C.F.M. Cubic Feet Per Minute
 R.P.M. Rotations Per Minute
 P.P.M. Parts Per Million
 L/min Liters Per Minute
 O₂% Oxygen Percentage of Gas
 B.P. Back Pressure

Cubic Feet Per Minute
 Rotations Per Minute
 Parts Per Million
 Liters Per Minute
 Oxygen Percentage of Gas
 Back Pressure

3.0 Safety And Operation Precautions

Because a compressor is a piece of machinery with moving and rotating parts, the same precautions should be observed as with any piece of machinery of this type where carelessness in operations or maintenance is hazardous to personnel. In addition to the many obvious safety precautions, those listed below must also be observed:

- 1) Read all instructions completely before operating any compressor or nitrox system.
- 2) For installation, follow all local electrical and safety codes, as well as the National Electrical Code (NEC) and the Occupational Safety and Health Administration (OSHA) standards.
- 3) Electric motors must be securely and adequately grounded. This can be accomplished by wiring with a grounded, metal-clad raceway system to the compressor starter; by using a separate ground wire connected to the bare metal of the motor frame; or other suitable means.
- 4) Protect all power cables from coming in contact with sharp objects. Do not kink power cables and never allow the cables to come in contact with oil, grease, hot surfaces, or chemicals.
- 5) Make certain that power source conforms to the requirements of your equipment.
- 6) Pull main electrical disconnect switch and disconnect any separate control lines, if used, before attempting to work or perform maintenance. "Tag Out" **and** "Lock Out" all power sources.
- 7) Do not attempt to remove any parts without first relieving the entire system of pressure.
- 8) Do not attempt to service any part while system is in an operational mode.
- 9) Do not operate the system at pressures in excess of its rating.
- 10) Do not operate compressor at speeds in excess of its rating.
- 11) Periodically check all safety devices for proper operation. Do not change pressure setting or restrict operation in any way.
- 12) Be sure no tools, rags or loose parts are left on the nitrox system.
- 13) Do not use flammable solvents for cleaning the air inlet filters or elements and other parts.
- 14) Exercise cleanliness during maintenance and when making repairs. Keep dirt away from parts by covering parts and exposed openings with clean cloth or Kraft paper.
- 15) Do not operate the compressor without guards, shields, and screens in place.
- 16) Do not install a shut-off valve in the compressor discharge line, unless a pressure relief valve, of proper design and size, is installed in the line between the compressor unit and shut-off valve.
- 17) Do not operate this compressor in any location where there is a possibility of toxic levels of carbon monoxide (CO), carbon dioxide (CO₂), nitrogen (N), or any flammable or toxic fumes being sucked into the compressor intake.
- 18) Be careful when touching the exterior of a recently run electric, gasoline, or diesel motor - it may be hot enough to be painful or cause injury. With modern motors this condition is normal if operated at rated load - modern motors are built to operate at higher temperatures.
- 19) Inspect unit daily to observe and correct any unsafe operating conditions found.
- 20) Do not "play around" with compressed air, or direct air stream at body, because this can cause injuries.
- 21) Compressed air from this machine absolutely must not be used for food processing or breathing air without adequate downstream filters, purifiers and controls and periodic air quality testing.
- 22) Always use an air pressure-regulating device at the point of use, and do not use air pressure greater than marked maximum pressure.
- 23) Check hoses for weak or worn conditions before each use and make certain that all connections are secure.

The user of any compressor or nitrox system manufactured by Nuair is hereby warned that failure to follow the preceding Safety and Operation Precautions can result in injuries or equipment damage. However, Nuair does not state as fact or does not mean to imply that the preceding list of Safety and Operation Precautions is all-inclusive, and further that the observance of this list will prevent all injuries or equipment damage.

4.0 Legal Precautions

It is highly recommended that a nitrox fill log be maintained when filling scuba cylinders to document the following information. This log must be of permanent binding style with no loose pages.

- ◆ Fill date and time of day
- ◆ Tank serial number
- ◆ Supplier's check of oxygen content O₂% plus signature and date
- ◆ User's check of oxygen content O₂% plus signature and date
- ◆ Fill pressure
- ◆ MOD (maximum operating depth) in user's handwriting
- ◆ Nitrox certifying agency and card number

5.0 Theory of Operation

The Voyager IV™ nitrox system is a turnkey package that produces oxygen-rich air (nitrox) and then compresses it with a High Pressure (H.P.) compressor to fill scuba tanks or storage cylinders. The package is designed to be fully automatic, with a quieted enclosure for noise reduction and protection from moving parts while it is running. Although it is described as the “nitrox compressor”, it can also be used to pump air.

The nitrox system allows for efficient and cost effective nitrox production using electric power, without the hazards or expense of blending with stored high-pressure oxygen (O₂). Instead, the system uses a semi-permeable membrane to produce nitrox from air. A portion of the nitrogen in air is separated out, leaving an oxygen rich nitrox mixture.

The Voyager IV™ uses a rotary screw L.P. compressor, air / oil aftercooler, refrigerated air dryer, and filtration to provide the membrane system with a source of clean, pressurized feed air for separation. The air is filtered to CGA Grade D or better air quality prior to entering the membrane system so it will not damage or plug the membrane fibers. Specifications for Grade D air are provided in the appendix.

The Voyager IV™'s membrane system is rated for a maximum feed air pressure of 300 P.S.I. (21 bar) and has been configured to work well with the 175 P.S.I. (12 bar) maximum pressure delivered by the L.P. compressor. A back-pressure regulator is used to adjust the amount of air the screw compressor produces to meet the appropriate levels for various O₂% nitrox production. The air is then heated to a temperature that provides stability over a wide range of ambient conditions, is optimal for membrane permeation, and prevents moisture condensation.

The heated air enters the membrane, which is made up of thousands of miniature hollow fibers. The walls of these fibers are semi-permeable and designed for different gases to move through them (or permeate) at different speeds. The resulting gas mixture is known as the “permeate.” As air flows through the hollow fibers, both oxygen and nitrogen permeate through the fiber walls. The oxygen permeates faster than the nitrogen, which produces permeate with oxygen content greater than air. The gas that reaches the end of the hollow fibers without permeating is almost entirely nitrogen and is discharged. The flow rate of this discharge is set by the factory via a fixed orifice, which controls the permeate.

The permeate is a concentrated mixture that is diluted with air prior to entering the H.P. compressor. It exits the membrane at ambient to slightly negative pressure and travels into the mixing tube, where it mixes homogeneously with filtered outside air. The amount of dilution, and thus final O₂%, is obtained by adjusting the amount of air produced by the compressor and supplied to the membrane, with the back pressure regulator. As air flow to the membrane is increased, permeate flow increases and a higher O₂% nitrox is produced. As air flow to the membrane is decreased, permeate flow decreases, compressor intake air increases, and a lower O₂% nitrox is produced.

This relationship between permeate flow and intake air flow exists because the total of these two flow rates will always equal the intake flow rate demanded by the H.P. compressor. The resulting nitrox mixture is analyzed for O₂% before entering the H.P. compressor for approximate content and again when pumping nitrox for precise content. The H.P. compressor pumps the nitrox to a maximum pressure of 3600 P.S.I. (250 bar) to fill scuba tanks or storage cylinders.

A unique feature of Nuvair nitrox systems is that the feed air pressure that correlates to a specific nitrox O₂% is repeatable. For example, if your H.P. compressor pumps 36% O₂ when the feed air pressure is at 125 P.S.I. (9 bar), then adjusting the back pressure regulator to 125 P.S.I. (9 bar) during the next use will produce the same mixture.

6.0 Low Pressure Compressor Technical Data

See separate manual for Rotair RVK20/12 L.P. compressor

Capacity and Power Consumption:

- Normal working pressure: 90-175 P.S.I. (6-12 bar)
- Capacity at normal working pressure: 62 (C.F.M.) cubic feet per minute (1750 l/min)
- Shaft power at normal working pressure: 20 horse power (15 kW)
- Maximum working pressure: 175 P.S.I. (12 bar)
- Minimum working pressure: 44 P.S.I. (3 bar)
- Idling shaft power consumption: 4.8 horse power (3.6 kW)
- Transmission: belt drive

Cooling:

- Allowed ambient temperature: 32-104° F (0-40° C)

Motor and Electrical Values:

- Motor: F class ODP, 20 horse power (15 kW) three phase
- Speed of rotation: 3450 R.P.M. @ 60Hz or 2850 R.P.M. @ 50Hz

General Technical Data:

- Oil capacity: 4 liters
- Maximum oil content in air: 3 mg/m³

Notice

Rotary screw compressors are continuous duty rated workhorses that are not made to run for short intervals or sit without use for long periods of time. The rotary screw compressor must be run for a minimum of one continuous hour per week in tropical settings to insure moisture does not build up in the compressor. The oil filter and oil/air separator must be changed every 2000 hours or a minimum of once per year. In tropical conditions the oil should be checked every month for moisture by draining a small amount off the bottom of the compressor into a clear glass. If moisture is found it can be drained off and a visual inspection should be done on all filters checking for rust or corrosion.

7.0 High Pressure Compressor Technical Data
See separate manual for Coltri MCH 30 H.P. compressor

Capacity and Power Consumption:

- Normal working pressure : 3600 P.S.I. (250 bar)
- Free air delivery flow: 17.5 C.F.M. (495 l/min)
- Charging rate: 21 S.C.F.M (595 l/min)
- Compressor speed of rotation: 950 R.P.M.
- Maximum working pressure air: 6000 P.S.I. (425 bar), nitrox 3600 P.S.I. (250 bar)
- Transmission: belt drive

Cooling:

- Allowed ambient temperature: 32-104° F (0-40° C)
- Air cooled Interstage & aftercooler

Motor and Electrical Values:

- Motor: F class ODP, 15 horse power (11kw) three phase
- Speed of rotation: 3450 R.P.M. @ 60Hz or 2850 R.P.M. @ 50Hz

General Technical Data:

- Number of stages: 4
- Number of cylinders: 4
- Lubrication: pressure & splash lubricated
- Oil capacity: 4.25 qt. (5 liters)
- H.P. filtration rating: CGA Grade E, 60,000 cu. ft. at 68° F (20° C) (see page 39 for filtration factor chart)
-
- Condensate drains: automatic & manual interstage & final
- Fill Pressure Stop: automatic & manual
- Low oil level auto shutdown
- High temperature auto shutdown
- Interstage pressure gauges

8.0 System Components

- Low pressure compressor, including:
 - ◆ Soft start motor starter
 - ◆ Hour meter
 - ◆ External lubricant sight gauge, fill, and drain
 - ◆ Nuvair 546™ food grade rotary screw compressor lubricant (see MSDS starting on page 40)
 - ◆ Large oil/air cooler with exhaust fan
- Refrigerated air dryer
 - ◆ Automatic condensate drain
- Back-pressure regulator that controls L.P. compressor feed air supply
 - ◆ Supply air pressure regulated between 90-175 P.S.I. (6-12 bar) depending on nitrox O₂%
- Low pressure feed air filtration, Grade D breathing air, including four stages:
 - ◆ Coalescing & particle removal to 1 micron, auto drain, liquid level indicator
 - ◆ Water & oil vapor removal to 0.01 micron, auto drain, liquid level & service life indicators
 - ◆ Oil vapor removal to 0.003 P.P.M.
- Heater including: (optional) not supplied with Nitrox Manager
 - ◆ Thermostat control
 - ◆ Digital temperature gauge
 - ◆ Pressure switch
 - ◆ 200 P.S.I. (14 bar) ASME over pressure relief
- Semi-permeable membrane
- Mixing tube & air intake filter
- Nuvair Pro O₂ Remote™ permeate oxygen analyzer
- Nitrogen discharge
- Nuvair Pro O₂™ fill oxygen analyzer, including:
 - ◆ High-Pressure/Low-Pressure regulator
 - ◆ Flow restrictor, 1 - 5 L/min
- High pressure compressor, including
 - ◆ Soft start motor starter
 - ◆ Hour meter
 - ◆ Automatic condensate drains
 - ◆ Automatic fill pressure stop
 - ◆ External lubricant sight gauge, fill, and drain
 - ◆ Compressor lubricant see page see MSDS page 40
- High pressure filtration, Grade E breathing air (see page 39 for filtration factor chart)
- Air/nitrox quality analysis kit

9.0 Nitrox System Specifications

L.P. Compressor	Delivery @ 175 P.S.I. (12 bar)	62 C.F.M. free air (1750 L/min)
	Horse Power – Electric	20 horse power (15 kW)
Physical Specifications	Height	67 in (170 cm)
	Width	62 in (158 cm)
	Depth	35 in (89 cm)
	Weight	1450 lb (658 kg)
Full Load Amps	230V / E3 / 50 or 60 Hz	128 Amps
	415V / E3 / 50 or 60 Hz	88 Amps
	440V / E3 / 50 or 60 Hz	74 Amps
Membrane Input	Operating Pressure Range	90 -175 P.S.I. (6-12 bar)
	Maximum Input Pressure	300 P.S.I. (21 bar)
	Feed Air Volume Range	13 - 60 S.C.F.M. (354 -1700 L/min)
	L.P. Feed Air Quality	Grade D
	Optimum Temperature	110 +/- 5°F (43 +/- 3°C)
	Nitrox O₂%Range	24 - 40%
H.P. Compressor	Charging Rate	21 S.C.F.M. (595 L/min)
	Horse Power – Electric	15 horse power (11 kW)

10.0 Nitrox Voyager IV System Component Identification

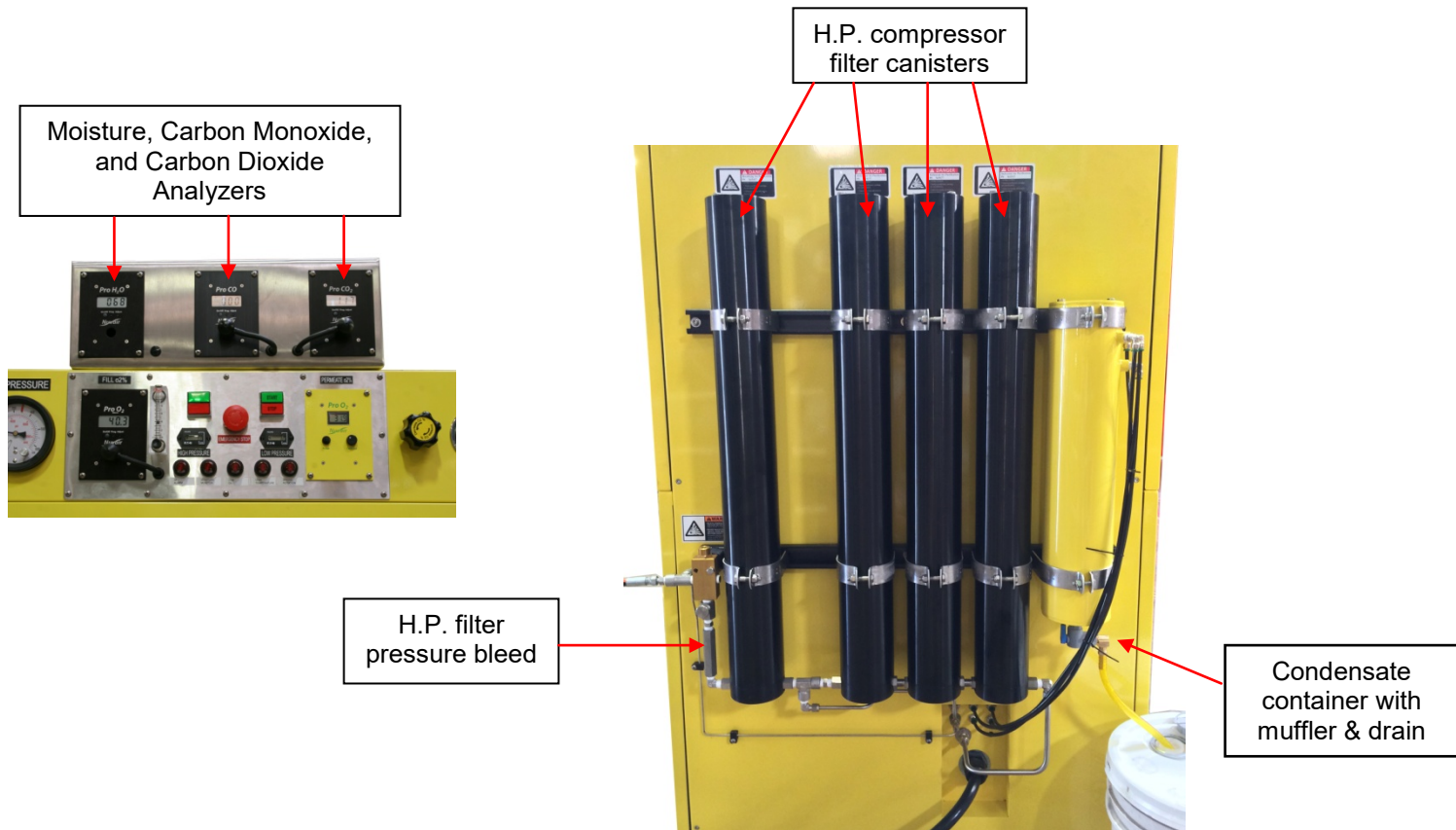
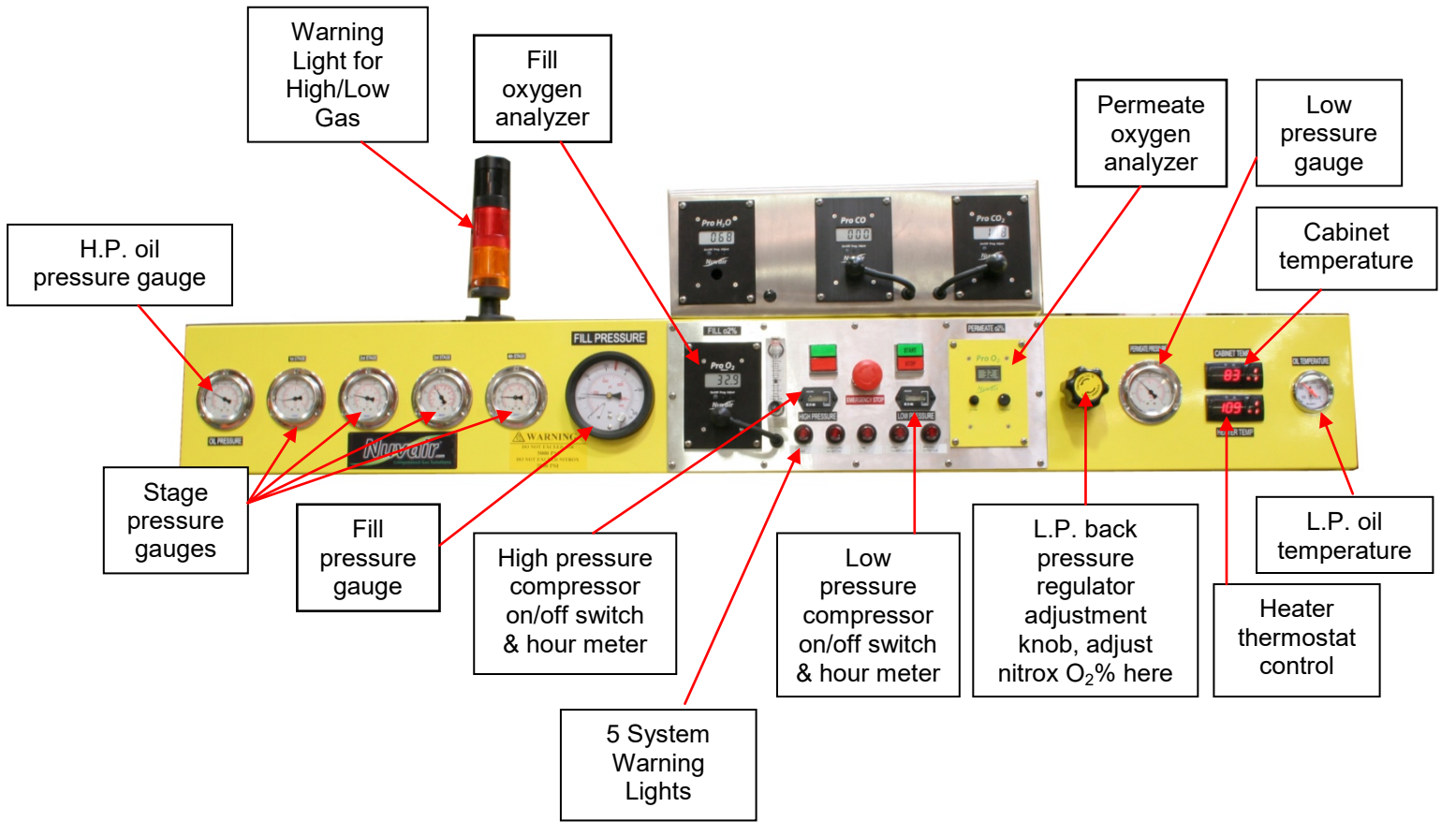

Voyager IV™ Nitrox System

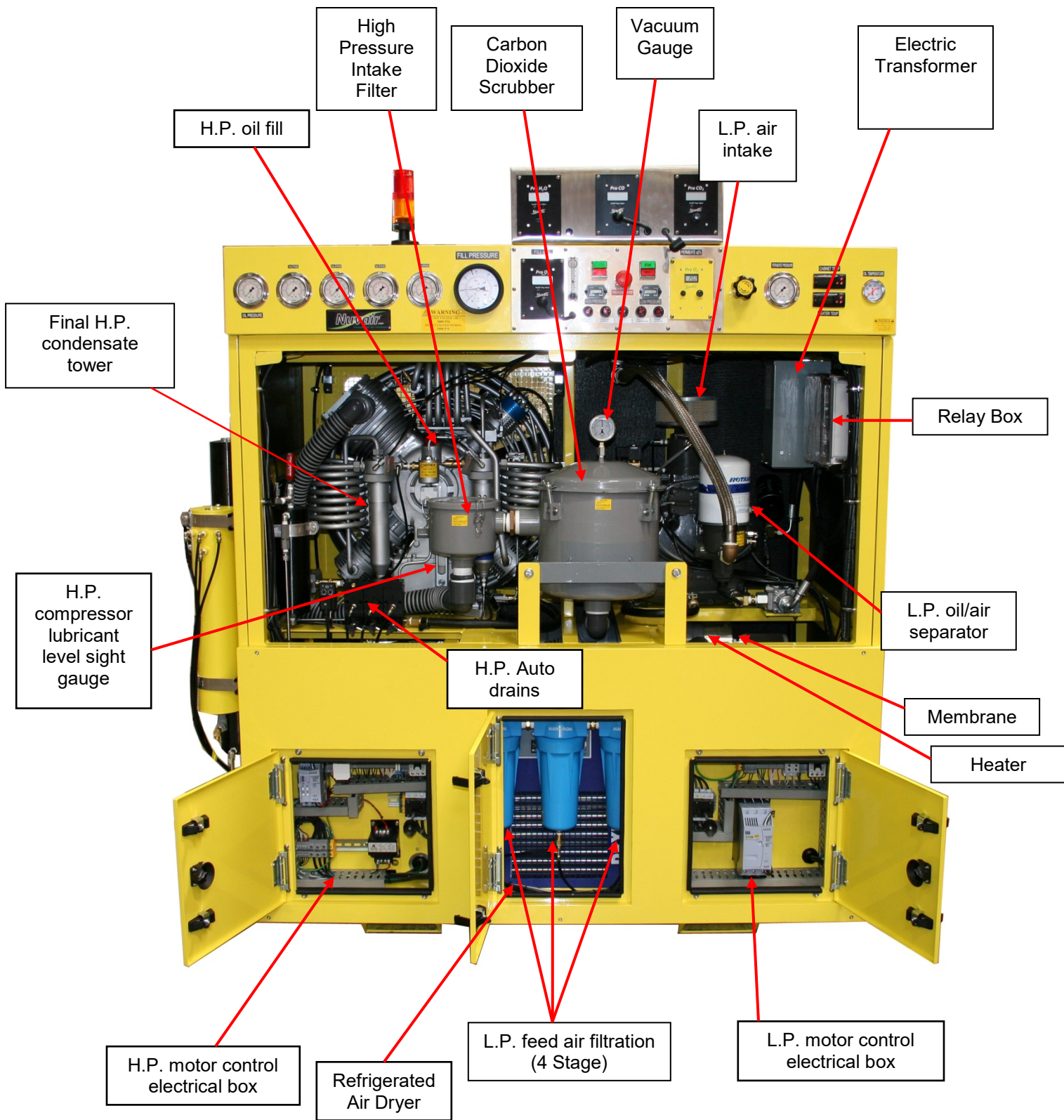

11.0 Options for the Voyager IV:

- Additional filtration and a larger condensate storage cylinder can be added to the Voyager IV.



- High amp disconnect or lock out switch may be installed.



- Dial-A-Pressure switch for preset shutoff of storage or hot fill cylinders
- Emergency shut off button
- Wrong Rotation, Low Oil, High Temp Cabinet- all three will shut down compressor

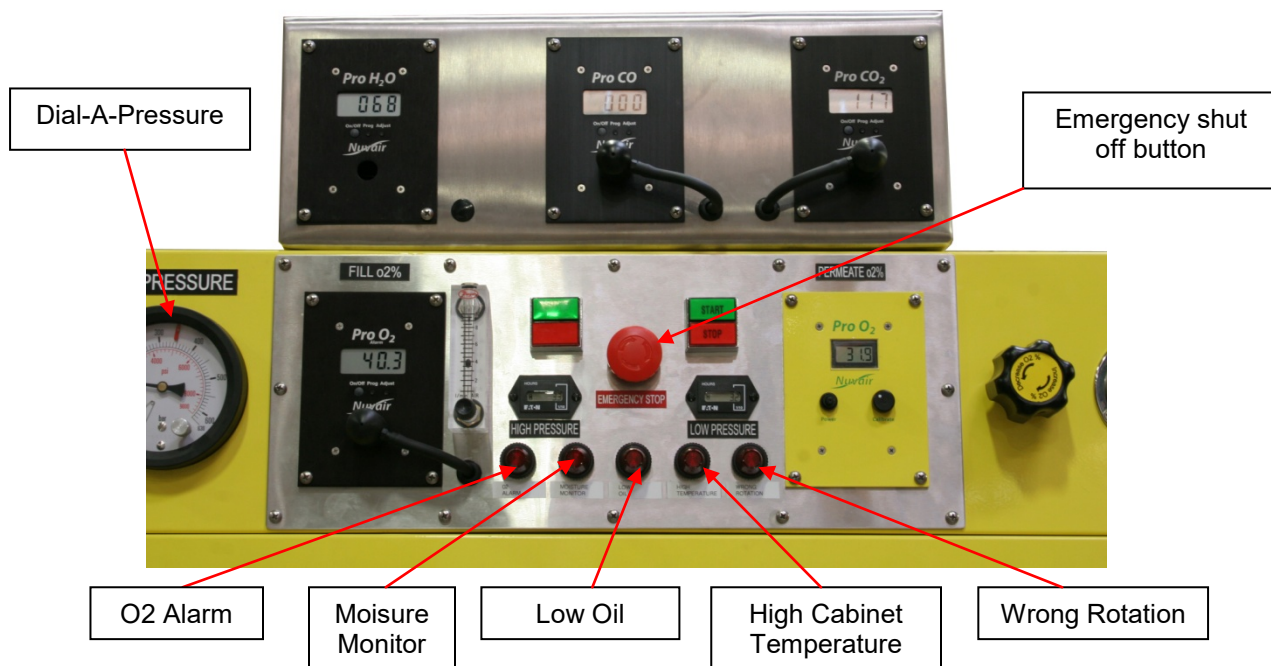

12.0 System Drawing / Schematic

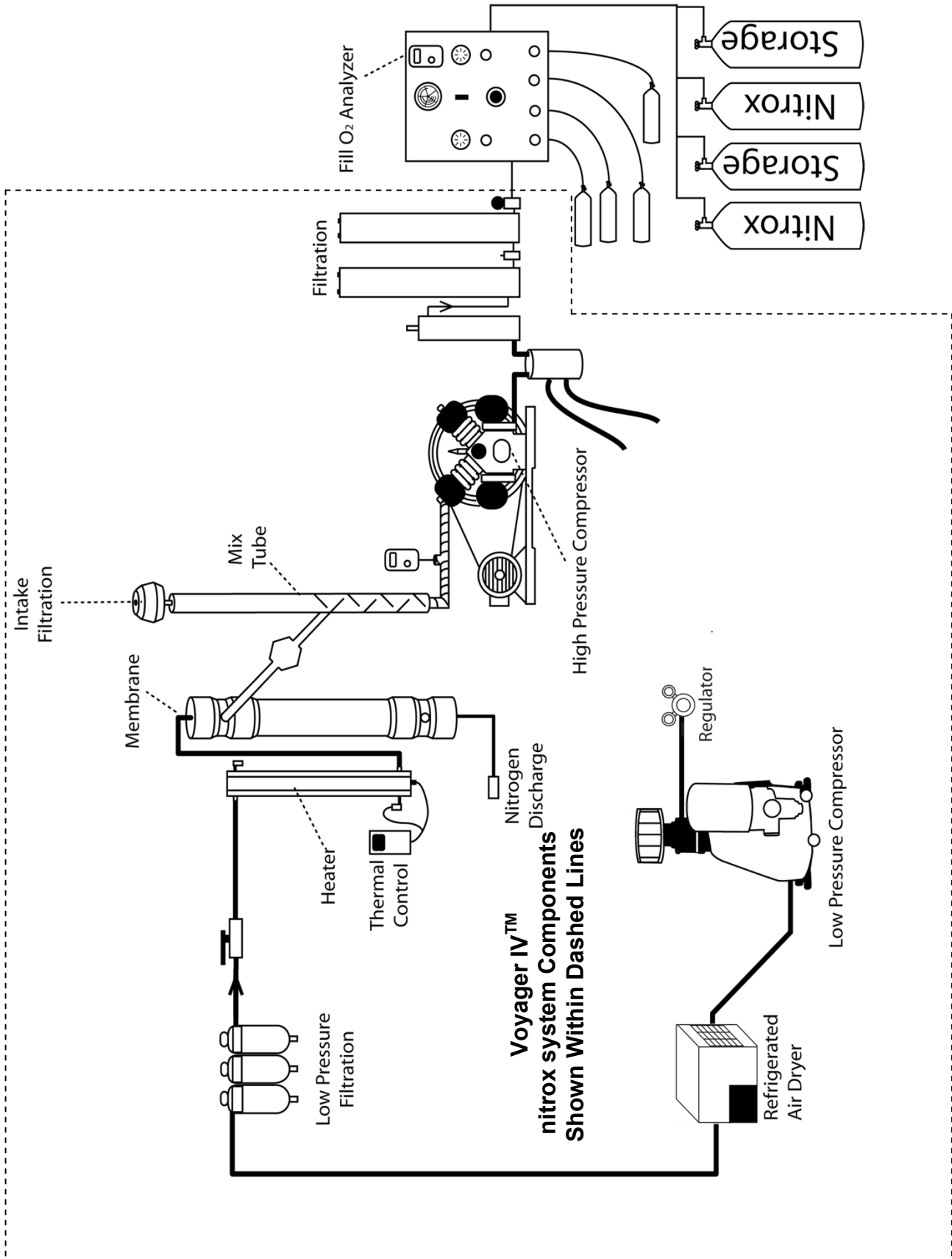

13.0 System Flow Chart

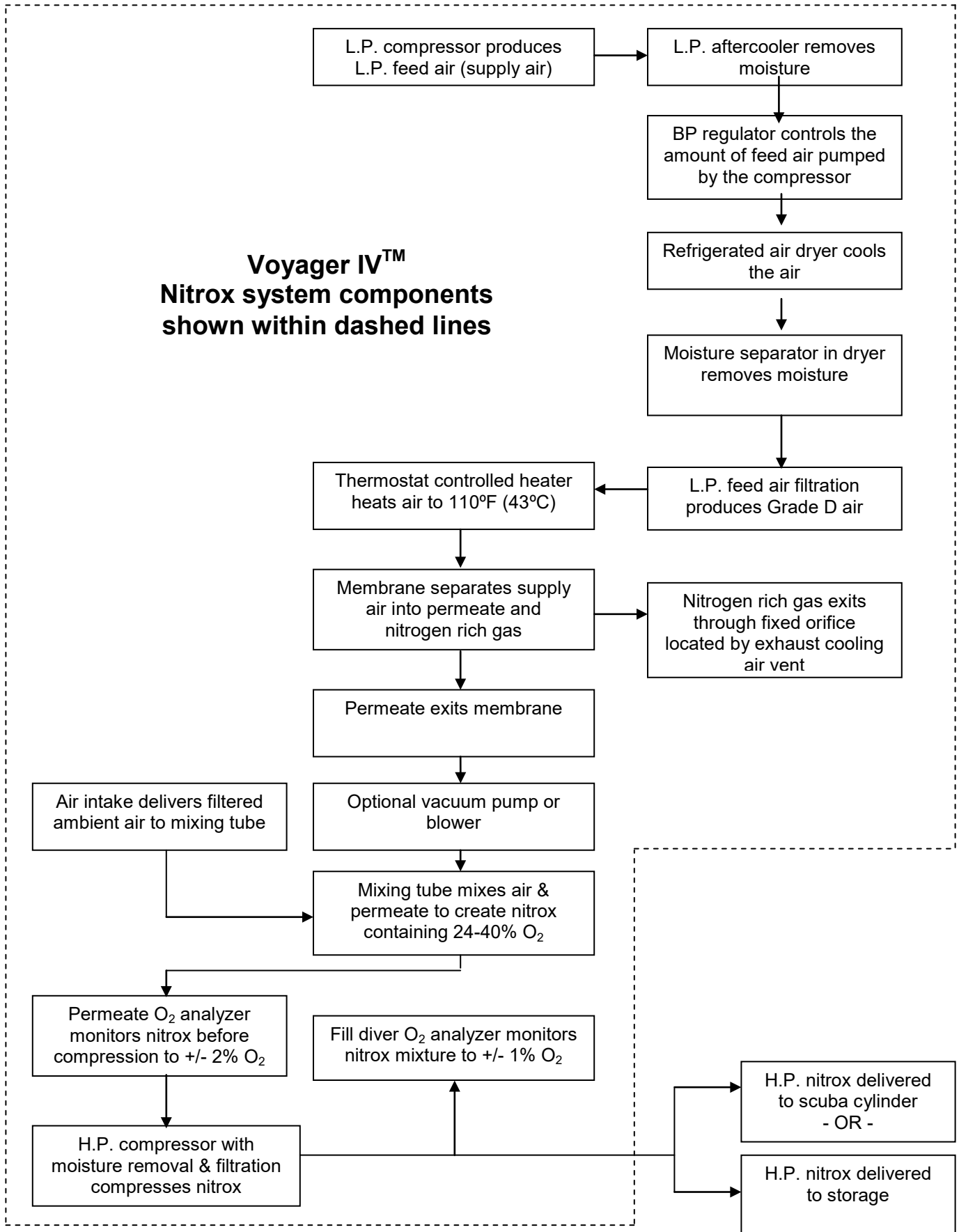

14.0 Installing the Voyager IV Nitrox System

Notice

If any information in this manual conflicts with any of the other manuals call Nuair before proceeding.

Caution

The Nuair System (Voyager IV) should never be operated in a facility where the room temperature exceeds 104° F (40° C) while the system is in use. Operation at higher temperatures may lead to system damage and malfunction. A damaged membrane will not produce the correct nitrox mixture which can lead to severe personal injury if the gas is used for diving purposes without proper analysis.

14.1 Precautions

1. Please read all information supplied before physically installing the nitrox system.
2. Unpack the system and remove from the pallet. Visually inspect the system to make sure there has been no damage during shipping. If damaged, please call Nuair to file a damage report. Please take photos and supply detailed information about the damage.
3. Place the system in a location that allows a minimum spacing of 18 inches from adjacent walls. Select a location where ambient room temperature will never exceed 104° F (40° C).
4. The heater thermostat has been set in the factory. Do not adjust.

14.2 Attaching Nitrogen Discharge Hose (option)

The nitrogen discharge from the membrane on the Voyager IV exits next to the exhaust air fan. The fan pushes over 3000 C.F.M. of exhaust air and as long as the fan is functioning there will be no need for an optional discharge, unless installed in an improperly vented room.



Warning

Pure nitrogen is a colorless, odorless, tasteless gas that will not support life. Breathing gas mixtures containing more than 84% nitrogen at surface pressures will lead to unconsciousness and may cause death.



Warning

The nitrogen discharge from the membrane should be vented to a well-ventilated room or to open air with good circulation. Failure to isolate the discharge from the air intake of the membrane system or L.P. compressor could lead to incorrect nitrox mixtures, resulting in serious personal injury or death. If you allow this pure nitrogen to accumulate in an enclosed space, anyone entering this space will quickly lose consciousness and will die if not immediately resuscitated.

14.3 Electrical Power Connection



Warning

Never use extension cords to provide power to your nitrox system. The system must be properly wired according to national and local electrical codes by a qualified electrician. Improper wiring may lead to fires, which can cause serious personal injury or death.



Warning

The electrical power to the Nuair Voyager IV must be off while wiring this system for service. Failure to ensure that the electrical power is off can lead to severe personal injury and death by electrocution.

Prior to making the electrical power connection, check all system specifications provided in this manual. When working on the nitrox system, the main breaker at the power source must be “locked out” and “tagged out” in the “Off” position. The nitrox system has electrical protection for the compressor Motor and membrane system Heater located inside the motor starter compartment.

Amperage Load for System

- ◆ Approximately 128 Amps for 230 V three phase service
- ◆ Approximately 88 Amps for 415 V three phase service
- ◆ Approximately 74 Amps for 440 V three phase service

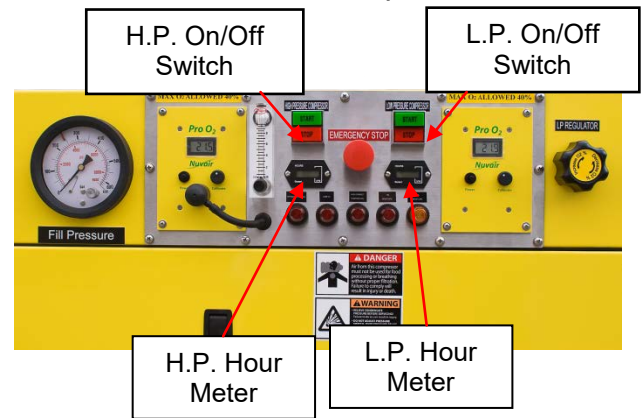

Compressor Rotation Check

Always turn on (bump) starter for both L.P. and H.P. compressors and run motor very briefly to check for proper direction of rotation (see arrow on belt guard and flywheel).



H.P. compressor Shown

Note Proper Direction of Rotation



Notice

Operation in reverse direction for extended periods of time will cause a reciprocating compressor to run hot and perform poorly and may cause permanent damage. Reverse rotation for a rotary screw compressor for even a short period of time will cause damage.

14.4 Check Compressor Lubricant Levels

Check lubricant levels before starting the L.P. and H.P. compressors and add lubricant as required. Use only the lubricants specified by Nuvaair.

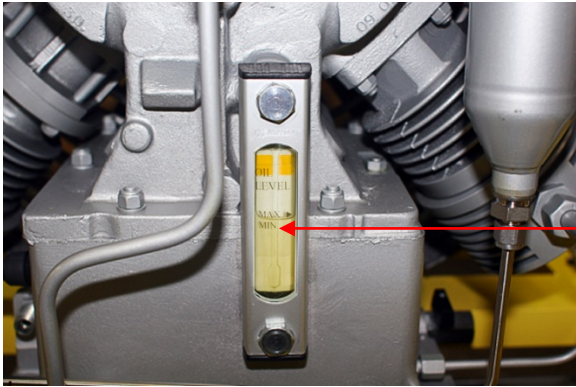

H.P. Compressor lubricant level sight gauge

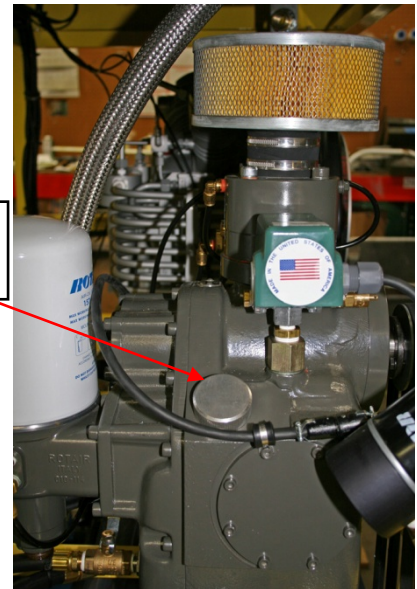

L.P. oil fill & dip stick



Warning

Do not allow nitrox to be discharged into the air storage system. Nitrox introduced into the air storage system could cause a diver to suffer from oxygen poisoning at depth. Oxygen poisoning is extremely dangerous and can lead to death by drowning.

Warning

Do not allow air to be discharged into the nitrox storage system. Air introduced into the nitrox storage system could cause a diver to suffer decompression sickness if the nitrox mixture is not analyzed properly and is used underwater under the assumption it is a different mix.

14.5 Control Panel Identification

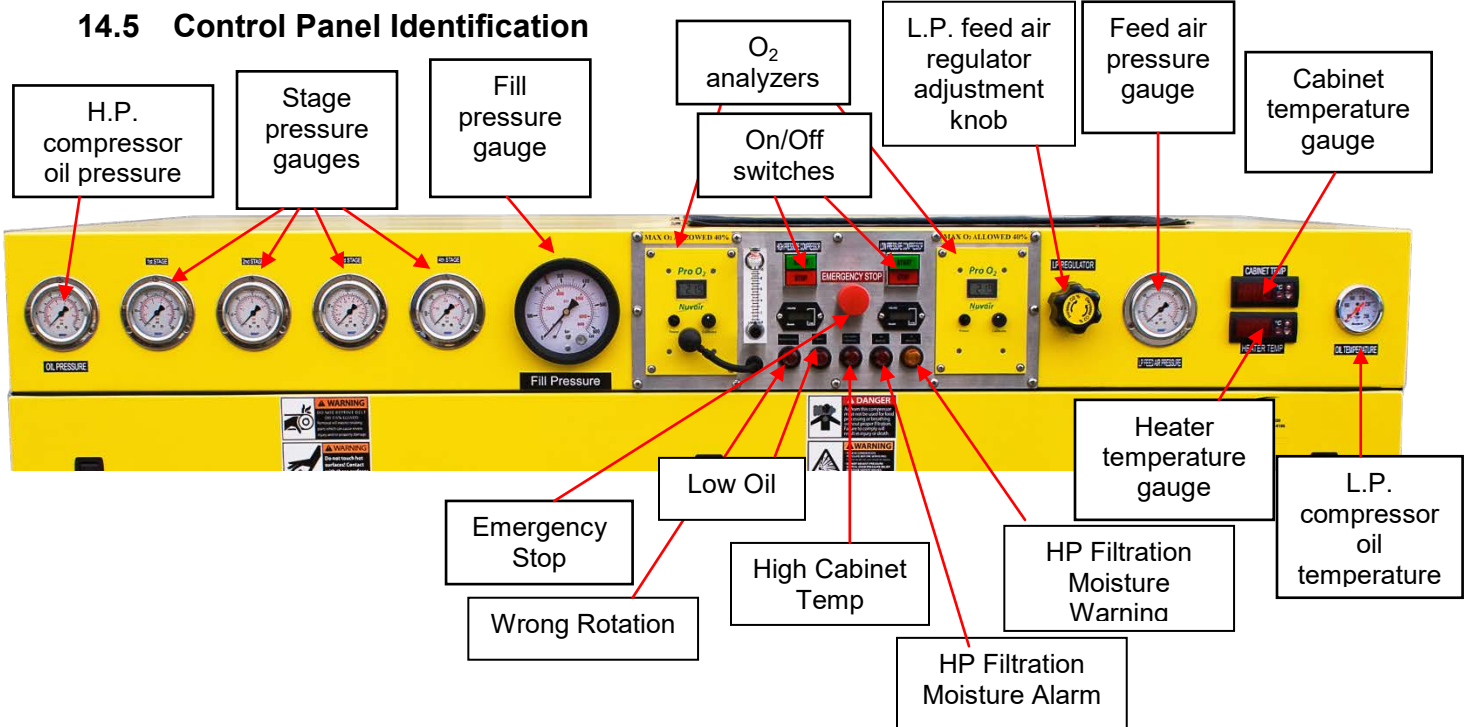

15.0 Pre-Operation Instructions

15.1 Calibrate Oxygen Analyzers

Gas production is monitored with the permeate oxygen analyzer before the compressed gas enters the H.P. compressor to obtain a rough estimate of O₂% (+/- 2%). Do not rely on this reading as a proper indication of percentage of oxygen at the H.P. compressor outlet. Prior to pumping nitrox from the compressor, it must be monitored with the fill oxygen analyzer to obtain a precise measurement of O₂% (+/- 1%). **Both oxygen analyzers must be calibrated prior to each use.**

Warning

Oxygen Analyzers must be calibrated before each use. See Oxygen Analyzer manuals for correct calibration procedures. Improper calibration of the Fill Oxygen Analyzer may result in the use of incorrect nitrox mixtures, which may cause serious injury or death to the diver using the gas mixture.

Warning

At altitudes above sea level, a correction factor must be used when calibrating the fill oxygen analyzer. It may not be possible to achieve all desired mixtures at altitude. See fill oxygen analyzer manual for correcting analyzer readings at various altitudes. Improper calibration of the fill oxygen analyzer may result in the use of incorrect nitrox mixtures, which may cause serious injury or death to the diver using the gas mixture.

Warning

The permeate oxygen analyzer supplies oxygen readings that can vary +/- 2% O₂ due to heat, humidity, and pressure changes experienced in the nitrox flow and therefore should only be used for rough estimates of O₂%. The fill oxygen analyzer supplies more accurate oxygen readings, within +/- 1% O₂. For cylinder nitrox fills, the user must always verify the final fill with a third independent oxygen analyzer.

15.1 Calibrate Oxygen Analyzers - Continued

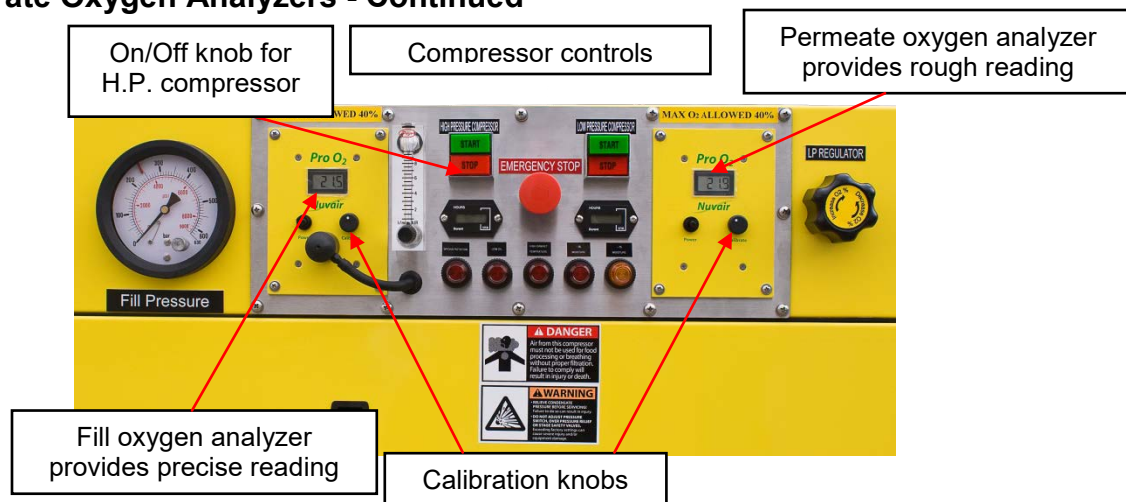

- 1) Turn on the high pressure compressor and allow to run for 1-2 minutes or until analyzers stabilize.
- 2) Crack open the bleed valve on the side of the compressor so that the running H.P. compressor maintains 1500-2000 P.S.I. (100-136 bar) outlet pressure. Air will now be flowing past both oxygen analyzers for calibration purposes.
- 3) Monitor all gauges for proper operating range and check all connections for leaks.
- 4) Calibrate oxygen analyzers while the H.P. compressor is pumping air. Refer to the oxygen analyzer manual included with the nitrox system for details. Note that special calibration procedures may be required when operating at altitudes above sea level.
- 5) Fill oxygen analyzer – Turn calibration knob so display reads 20.9%.
 - a. Fill oxygen analyzer – Remove the flow adapter cap covering the sensor.
 - b. Expose the sensor to ambient air for approximately 15 seconds.
 - c. Adjust calibration knob until display reading stabilizes at 20.9%.
 - d. Reinstall the flow adapter cap to the analyzer.
 - e. The fill oxygen analyzer is now ready for use. Different settings may be used depending on heat, humidity and altitude verify your actual ambient conditions and refer to the oxygen analyzer manual for details.
- 6) Turn on the L.P. compressor and increase the pressure to a minimum of 90 P.S.I.
- 7) Allow the compressors to run for a 10 minute warm up period for the membranes to warm up and stabilize. Check the heater temperature gauge to verify air temperature rises and is between 105-120 °F (40-49 °C).
- 8) Now that the system temperature has stabilized, you must recalibrate the fill O₂ analyzer. See step (5a) above for calibration.

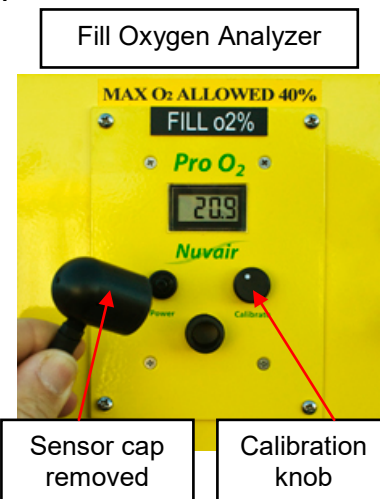

Notice

The oxygen analyzers may require re-calibration after 10-20 minutes of operation due to humidity and temperature change effects on the sensor. To recalibrate, turn off the L.P. feed air and follow calibration instructions.

16.0 Producing Nitrox

Before using your nitrox system to pump nitrox, test a sample of the nitrox produced using the air/nitrox quality analysis kit provided to verify compliance with CGA standards or applicable standards for intended use. Quarterly testing is mandatory once the system is operational.

Warning

The equipment you will be using to manufacture nitrox (oxygen rich air) will expose you to both low and high-pressure gas. Gas, even under moderate pressures, can cause extreme bodily harm. Never allow any gas stream to be directed at any part of your body.

Notice

Do not change the temperature setting on the thermostat control without contacting NuVair. Changes in temperature settings may cause membrane damage. A damaged membrane will not produce the correct nitrox mixture which can lead to severe personal injury if the gas is used for diving purposes without proper analysis.

16.1 Flow to Membrane and Setting Proper Pressure

The membrane system feed air pressure determines the oxygen percentage of the nitrox mixture. As pressure is increased, a higher oxygen percentage of nitrox is pumped. As pressure is decreased, a lower percentage of oxygen is pumped.

- 1) Increase pressure by slowly turning the back pressure regulator knob clockwise while monitoring the L.P. pressure gauge and permeate oxygen analyzer. As the pressure rises, watch the corresponding increase in the analyzer O₂% reading.
- 2) Increase or decrease pressure slowly until the permeate oxygen analyzer displays the percentage of oxygen desired in the final nitrox mixture.
 - Regulated membrane system pressure range should be 90– 175 P.S.I (6-12 bar), depending on nitrox O₂% being produced.
 - Heater temperature range should be 105-120° F (40-49° C).

16.2 Final Adjustments Before Pumping nitrox

- 1) As the nitrox initially makes its way through the running H.P. compressor, the O₂% reading on the fill oxygen analyzer will slowly increase to read approximately the same O₂% as the permeate oxygen analyzer. This should happen within 3-5 minutes.
- 2) When the two analyzers read within +/- 1%, make any final adjustments to the membrane system feed air pressure necessary to obtain the exact nitrox O₂% desired as indicated on the fill oxygen analyzer.
- 3) The system is now ready to pump nitrox.
- 4) Now you're ready to close the bleed valve and open the valve to the storage system.



Fill oxygen analyzer

Warning

The use of enriched air nitrox does not eliminate the risk of decompression sickness (DCS) in diving. Decompression sickness can lead to permanent disability or death.

Warning

The permeate O₂ analyzer supplies oxygen readings that can vary +/- 2% O₂ due to heat, humidity, and pressure changes in the nitrox flow and should only be used for rough estimates of O₂%. The fill O₂ analyzer supplies more accurate readings, within +/- 1% O₂. For scuba cylinder fills, the user must always verify the fill with a third independent O₂ analyzer.



Warning

Do not use this system to produce nitrox mixtures containing more than 40% oxygen. Pumping nitrox mixtures with higher concentrations of oxygen may lead to fires or explosions, which can cause serious personal injury or death.



Warning

Do not pump nitrox mixtures at pressures above the H.P. compressor rating, and never above 3600 P.S.I. (250 bar). The system is not rated for pressures above 3600 P.S.I. (250 bar). Higher pressures may lead to explosions which may cause serious personal injury or death.

Notice

No oxygen cleaning of standard cylinders or plumbing is mandatory when using the nitrox system to produce nitrox containing a maximum of 40% oxygen. When filling oxygen clean cylinders, hyper-purification of the nitrox is required using an optional oxygen compatible air purification system available from Nuair.



Warning

This nitrox system does not produce nitrox mixtures acceptable for 100% oxygen service. Mixing nitrox mixtures with 100% pure oxygen may lead to fires and / or explosions, which may cause serious personal injury or death.



Warning

Never fill a cylinder that is marked, "For Oxygen Service," with nitrox that has been produced by anything other than 100% oxygen clean system. Filling an oxygen clean cylinder with breathing gas containing hydrocarbons can lead to explosions if the cylinder is subsequently filled with gas mixtures containing gas mixtures containing greater than 40% oxygen. Explosions may cause serious injury or death.

Warning

Only provide scuba cylinder nitrox fills to customers who have proof of nitrox training and certification. Improper use of nitrox can cause severe personal injury or death.



⚠ Danger

This system is not cleaned for oxygen service and not all components are compatible with gas mixtures containing greater than 40% oxygen. Pumping gas mixtures containing greater than 40% oxygen will lead to explosions which may cause severe personal injury or death.

⚠ Warning

Each scuba cylinder belonging to a customer must be analyzed by that customer at the nitrox filling facility, using an oxygen analyzer independent of those used with the nitrox system. An employee must witness that the customer has properly analyzed the gas in each cylinder, noted the maximum operating depth for that mixture, and signed and dated the fill log. The time of day must also be included with the date, since some customers may fill the same cylinder more than once a day.

16.3 Pumping Nitrox

- 1) When filling a scuba cylinder, follow all industry standards. Do not exceed rated pressure of cylinder, and do not exceed 3600 P.S.I. (250 bar) under any condition.
- 2) With fill whip bleed valve open and nitrox flowing, verify that fill oxygen analyzer O₂% reading equals the desired nitrox O₂%.
- 3) Close bleed valve, open cylinder valve, and fill cylinder. Monitor system for proper operation:
 - a) Monitor oxygen analyzers and recalibrate as required
 - b) Listen for proper operation of automatic condensate drains every 10-15 minutes.
 - c) Monitor all system gauges as shown in the table below.

⚠ Notice

The Oxygen Analyzers may require re-calibration after 10-20 minutes of operation due to humidity and temperature change effects on the Sensor. To recalibrate, turn off the L.P. feed air switch and follow calibration instructions.

⚠ Notice

When the H.P. compressor auto drain engages and dumps condensate, the fill oxygen analyzer reading will decrease momentarily due to the pressure drop in the system. It will return to its previous reading within seconds after the auto drain sequence stops.

GAUGE	RECOMMENDED SETTING
Compressor Gauges	According to manufacturers recommendations
Heater Temperature	105 - 120° F (40 - 49° C)
Cabinet Temperature	Less than 100° F (38° C)
Membrane Feed Air Pressure	90 – 175 P.S.I. (6 - 12 bar) depending on Nitrox O ₂ %
Fill Oxygen Analyzer	Showing the proper reading for intended fill
Nitrox Storage Pressure	<u>DO NOT</u> exceed rating of tank or 3600 P.S.I (250 bar)

16.3 Pumping Nitrox (continued)

- 4) After filling is complete, close the cylinder valve, vent the bleed valve, and remove the cylinder.
- 5) Test the nitrox O₂% in the cylinder using an independent oxygen analyzer such as the Nuair O₂ Quickstick™. Calibrate the analyzer before use in accordance with manufacturer’s instructions.
- 6) Repeat steps 1-5 until you have filled all scuba cylinders.
- 7) Mark each tank with fill date, O₂%, fill pressure, and MOD (Maximum Operating Depth).
- 8) Log every nitrox fill to document the following information:
 - Fill date and time of day
 - Tank serial number
 - Supplier’s check of oxygen content O₂% plus signature and date
 - User’s check of oxygen content O₂% plus signature and date
 - Fill pressure
 - MOD (Maximum Operating Depth) in user’s handwriting
 - Nitrox certifying agency and card number
- 9) When filling a H.P. nitrox storage tank, verify that fill oxygen analyzer O₂% reading equals the desired nitrox O₂%. Open applicable line valves and tank valve, and fill with nitrox. Do not exceed rated pressure of cylinder, and do not exceed 3600 P.S.I. (250 bar) under any condition. After filling is complete, close all valves and allow nitrox system to shut down.



Use independent oxygen analyzer for verification

⚠ Notice

High-pressure cylinders that are filled quickly will become hot and due to the increased internal temperature the cylinder pressure will increase. This will leave a diver with less pressure inside the cylinder once cooling has occurred. This will decrease the amount of time the diver may spend underwater which may be critical during a deep dive. Customers must be warned of this possibility if cylinders are delivered for use while warm. Always fill all breathing gas cylinders slowly to avoid overheating.

! Notice

Always use Oxygen Analyzers to monitor oxygen content of any gas flowing through the system. Both air and nitrox are subject to variations in oxygen content.

16.4 Pumping Air

To use the system to pump air, simply turn off the L.P. compressor. No nitrox will be supplied to the H.P. compressor, and it will pump air only. When the H.P. compressor is pumping air, the permeate oxygen analyzer and the fill oxygen analyzer should both read 20.9 O₂%.

16.5 Shutting Down

- 1) When the storage banks are finished filling and tank valves are closed, the nitrox system will automatically shut down at the pressure set on the pressure switch (3600 P.S.I.) (250 bar).
- 2) Manually shut off the membrane system by turning the feed air regulator adjustment knob counter-clockwise to reduce pressure to minimum setting and then turn off the L.P. & H.P. compressors.
- 3) The system will automatically drain all filters, compressor, and volume tank condensate.

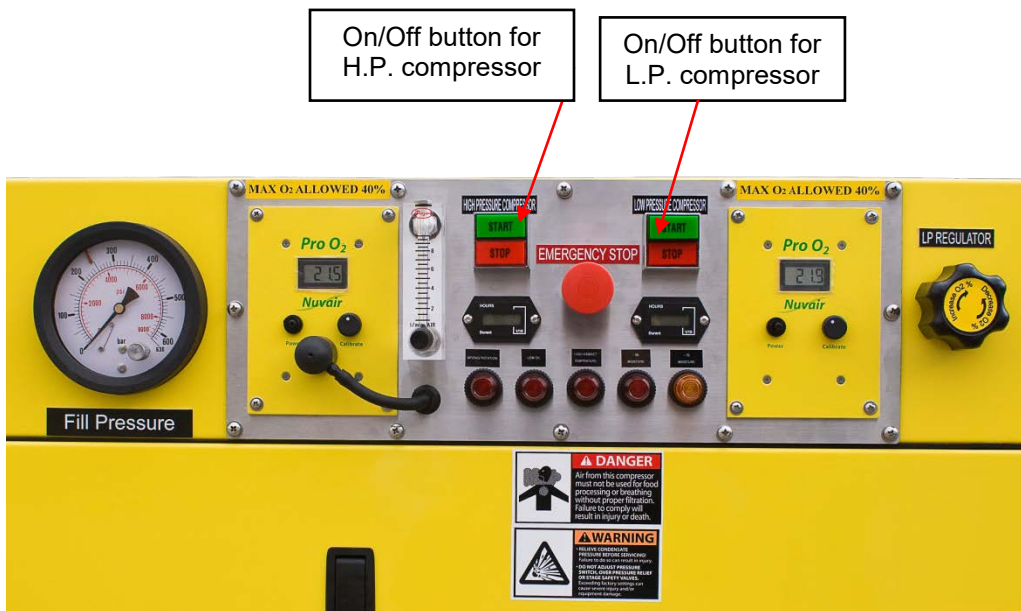

17.0 Nitrox Operation Notes

- Ensure all personnel who operate the system are properly trained in its use.
- Keep a log with details of each cylinder filled with nitrox, including the time and date, name of operator of system, name and certification number of diver, gas analysis, MOD, and cylinder pressure.

17.1 Correlation of Feed Air Pressure to Oxygen Content

After the 10 hour break-in period for your nitrox system, you will notice that specific nitrox oxygen percentages always match specific feed air pressures once the system has warmed up. These pressures and percentages will be repeatable. If you find that the fill oxygen analyzer reads 36% O₂ when the feed air pressure is at 125 P.S.I. (9 bar), record this pressure or make a mark on the feed air pressure gauge indicating the O₂%. Do this for each O₂% that you normally make, making sure system has warmed up first. The next time nitrox with 36% O₂ is needed, adjust the regulator to 125 P.S.I. (9 bar) and wait for the oxygen analyzer reading to stabilize. You will find the analyzer reading to be very close to 36% O₂, requiring only minor adjustments of the regulator to achieve the exact desired O₂%.

Notice

Use the fill oxygen analyzer to verify the nitrox oxygen percentage prior to pumping. When using the feed air pressure reading to obtain specific oxygen percentage, minor adjustments of the feed air pressure regulator may be required to obtain the exact percentage desired.

17.2 Hot Fills

While in the process of filling H.P. nitrox storage tanks, you may have a need to supply a walk-in customer with a scuba cylinder fill of a different nitrox mix. You can change mixes as follows:

- 1) With the nitrox system operating, isolate the H.P. nitrox storage tanks from the H.P. compressor by closing the appropriate valves.
- 2) Record the membrane system feed air pressure reading.
- 3) Slightly open fill whip valve on the H.P. compressor, and adjust so the running compressor maintains 1500-2000 P.S.I. (100-136 bar) outlet pressure.
- 4) Adjust the backpressure feed air regulator to the pressure corresponding to the desired nitrox O₂% for the scuba cylinder fill.
- 5) Allow the fill oxygen analyzer reading to stabilize, make any minor adjustments necessary to achieve the desired O₂%, and then fill cylinder in normal manner.
- 6) When finished return regulator to previous setting, and allow the fill oxygen analyzer reading to stabilize. Make any minor adjustments necessary to achieve the desired O₂%, and then resume filling storage tanks.

18.0 Maintenance

The following list of daily and routine maintenance items is intended as a guide. Refer to L.P. and H.P. compressor manuals for complete maintenance requirements.

18.1 Daily Maintenance

Caution

Be sure to check compressor lubricant levels prior to each day of operation. Failure to ensure the proper lubricant level will lead to system damage.

- 1) Check lubricant levels of both L.P. and H.P. compressors and add proper lubricants as required. See Section 17.3 and compressor manuals for details.
- 2) Slightly open each H.P. and L.P. manual condensate drain valve to verify that no condensate is present.
- 3) Check L.P. air filtration for condensate and proper operation of condensate drains.

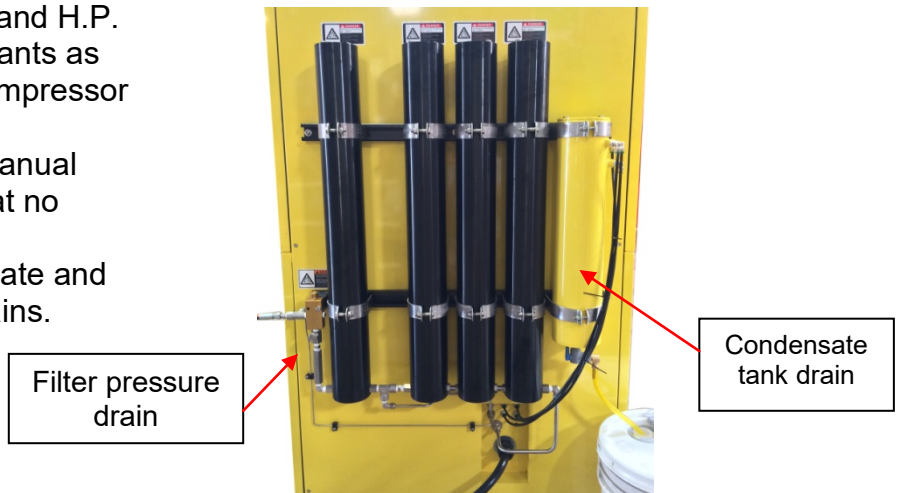

Warning

Use only the specified Nuvair lubricants in this system. The use of incompatible lubricants presents a risk of fire and/or explosion, and may result in system damage. This can lead to severe personal injury and death.

Be sure that any filtration opening the

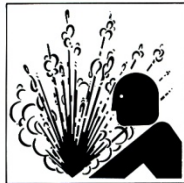

all pressure has been relieved from the system prior to opening canister. Failure to vent pressure from the system prior to canister can lead to serious personal injury or death.

Caution

If system is located in an area where there is high humidity and high heat, the life of all filtration elements may be as little as 35% of rated operating capacity. Check the compressor manual and appendix for details on filter element life factors.

18.2 Routine Maintenance

- 1) L.P. Compressor Lubricant: Change compressor lubricant every 1000 hours or annually. Only use lubricants rated for use with nitrox, such as Nuvair 546™. Never mix compressor lubricants. See Section 18.3 and L.P. compressor manual for details.
- 2) H.P. Compressor Lubricant: Change compressor lubricant every 100 hours or annually, whichever comes first. Only use lubricants rated for use with nitrox, such as Nuvair 455™. Never mix compressor lubricants. See Section 18.3 and H.P. compressor manual for details.
- 3) L.P. Air Filtration Inspection: On a weekly basis, inspect each filter bowl for the presence of moisture and each Element for any unusual degradation or wetness. See Section 18.5 for details.
- 4) L.P. Air Filtration Elements: Change L.P. filter elements every 500 hours or annually to maintain CGA Grade D air standards. Visual liquid level and service life indicators assist with monitoring replacement intervals. See Section 18.5 for details. If the nitrox system is operated in high humidity and/or high temperature, filter elements must be changed more often. See appendix for details on filter element life factors.
- 5) H.P. compressor Filtration Element: Change H.P. Filter Element every 60,000 cubic feet of air or nitrox processing to maintain CGA Grade E air standards. See Section 18.7 for details. If the nitrox system is operated in high humidity and/or high temperature the filter element must be changed more often. See appendix for details on filter element life factors.
- 6) Condensate Drain Container with valve open: Check level of attached bucket and drain weekly or as needed.
- 7) Semi-Permeable Membrane: No maintenance required. Service life exceeds 20 years if L.P. air filtration is properly serviced to maintain oil free Grade D air standards.
- 8) Membrane System Air Intake Filter: Inspect filter element every 3 months for visible particles. Change every 12 months or sooner if particles are visible.
- 9) Oxygen Analyzers: Replace oxygen sensor and battery as required. See manual included with nitrox system.
- 10) Air/nitrox Quality Analysis: Take breathing air/nitrox samples quarterly for analysis to assure compliance with CGA Grade E breathing air standards.

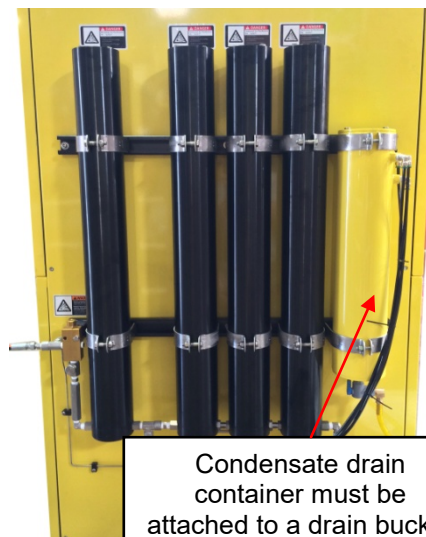

Condensate drain container must be attached to a drain bucket and left open. Check and drain the bucket weekly or as needed.

Danger

Do not swallow (ingest) either the electrolyte from the oxygen sensor or the sensor itself. The Potassium Hydroxide chemical contained in the sensor can cause severe injury or death. If electrolyte or the Sensor is swallowed, seek medical attention immediately.



Danger

If after handling the oxygen analyzer or sensor, you find that your fingers or other parts of your body feel “slippery” or the skin or eyes sting, immediately flush affected area with clean, fresh water for at least 15 minutes. The stinging or slippery sensation is an indication of a leaking Sensor. The Potassium Hydroxide chemical contained in the sensor can cause severe injury or death. Seek immediate medical attention if eye contact is made or skin stinging persists.



Warning

Use only the specified Nuvair lubricants in this system. The use of incompatible lubricants presents a risk of fire and/or explosion, and may result in system damage. This can lead to severe personal injury or death.

18.3 Compressor Lubricants (see page 40 - 43 for Material Safety Data Sheets)

- The L.P. compressor in your nitrox system comes standard with Nuvair 546™ synthetic food grade compressor lubricant for rotary screw compressors. Customers may specify different lubricants, check lubricant page at the back of manual for accepted lubricants.
- The H.P. compressor comes with the Nuvair 455™ synthetic food grade lubricant. Customers may specify different lubricants, check lubricant page at the back of manual for accepted lubricants.
- Check lubricant levels at each sight gauge and add lubricant as required through the appropriate lubricant fill plug.
- Lubricant is removed through the drain plugs. See L.P. and H.P. compressor manuals for details on servicing lubricant

Warning

Never mix different lubricants together because equipment damage may occur when machinery is operated with improper lubricant.



Warning

Do not carry out any maintenance tasks if the compressor has just shut down. Wait for the compressor to cool to avoid skin burns.

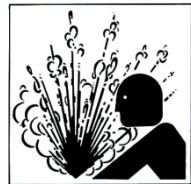

Warning

Pressure must be properly drained from the system before opening the L.P. fill plug. Failure to drain pressure may result in severe personal injury.



Warning

Any oil spilled during the oil and oil filter change could cause personnel to slip and fall. Wear anti-slip footwear. Remove any traces of spilled oil immediately. Slips and falls may cause severe personal injury or death.

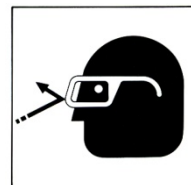

Caution

Wear eye protection, gloves, and skin protection when performing oil changes. Although the oil is not classified as a dangerous substance, the oil can be irritating to your eyes and skin.

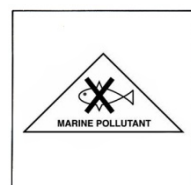

Caution

Both oil and oil filter are classified as “special wastes” and must be disposed of properly according to applicable national and local laws. Failure to dispose of these wastes properly can lead to death of wildlife as well as government fines and penalties.



Warning

All maintenance work must be carried out with the compressor off and the power supply lead unplugged from the main socket. Appropriate steps must be taken to tag out and lock out the electrical power. Failure to isolate this equipment from the power source while performing maintenance may result in severe personal injury or death.

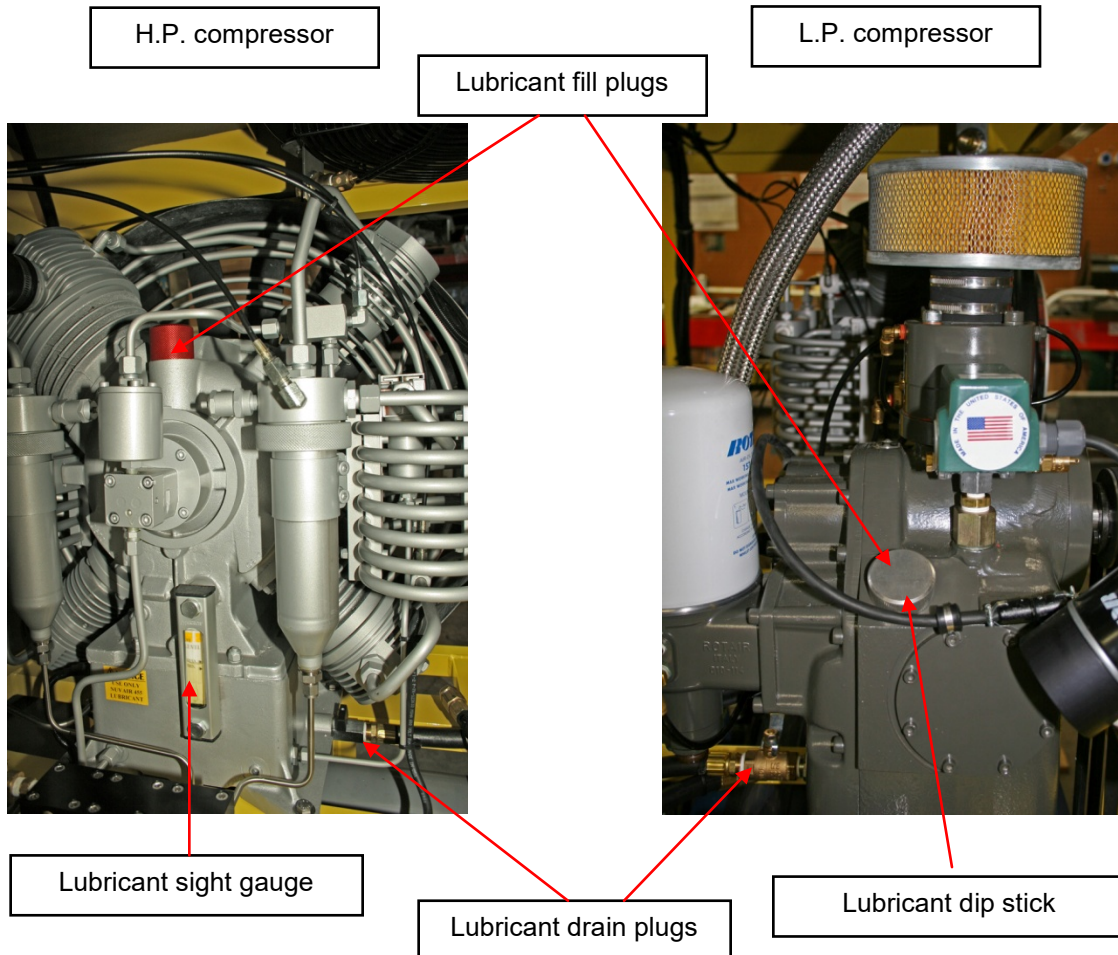

- The L.P. compressor in your nitrox system comes standard with Nuvair 546™ synthetic food grade compressor lubricant for rotary screw compressors.
- The H.P. compressor comes with the Nuvair 455™ synthetic food grade lubricant.
- Check lubricant levels at each sight gauge and add lubricant as required through the appropriate lubricant fill plug.
- Lubricant is removed through the drain plugs. See L.P. and H.P. compressor manuals for details on servicing lubricant

18.4 L.P. Feed Air Filtration and Bowls

⚠ Caution

Special attention needs to be given to the arrangement of the four L.P. feed air filtration elements and bowls. Properly reinstall each element and bowl to the correct housing. Improper sequence can cause damage to downstream components

The use of Grade D or better feed air is critical to prevent the passing of any residual oil vapor into the membrane system. Four stages of Hankison L.P. filtration are used to produce Grade D air:

- 1) Coalescing filter (Beko)
- 2) Coalescing & water/oil vapor removal to 1 Particulate micron (HF7-24)
- 3) Coalescing & water/oil vapor removal to 0.01 Particulate micron (HF5-24)
- 4) Final stage - oil vapor removal to 0.003 PPM (HF1-24)

18.5 L.P. Filtration Inspection

Open each Filter and inspect as follows:

Inspect the bowl for the presence of moisture. A high level of moisture build-up in the HF11-20 or HF7-24 filter indicates improper operation of auto-drain floats. Evidence of any moisture in the HF1=24 filter indicates air is not cooling properly and moisture is not properly being removed. Check HF1 canister weekly for moisture. Moisture indicates possible refrigerated dryer problem. Excess moisture will prevent the final filter from operating properly and can lead to damage of the membrane.

←
Air Flow

HF1-24	HF5-24	HF7-24	HF11-20
Oil vapor removal	Coalescing water & oil vapor removal	Particle & moisture removal	Coalescing
Replacement Element Part Number			
E1-24	E5-24	E7-24	E11-20

Housing

Element inside bowl

Bowl

HF1-24
Filter with manual drain should not contain moisture

HF5-24
Filter with auto-drain float & liquid level indicator & service indicator

HF7-24
Filter with auto-drain float & liquid level indicator & service indicator

18.6 Changing L.P. Filtration Elements

Change filtration elements every 500 hours. If the nitrox system is operated in high humidity and / or high temperature, filter elements must be changed more often. See appendix for details on filter element life factors. Visual service indicators on the HF7 & HF5 filters assist with monitoring replacement intervals.

- 1) Push up on filter bowl, rotate counter-clockwise, and lower to remove.
- 2) Gently unscrew filter element and pull down off mounting post.
- 3) Replace filter element and reassemble bowl in reverse order.

Changing L.P.
filtration element



Differential pressure indicators. Color indicates when filter should be changed

Housing

Element inside bowl

Bowl

Notice

The interior of the Filter Bowls can be cleaned with a diluted solution of Simple Green™ and flushed thoroughly with clean water. This will assist to prolong the life of the element, bowl, and auto drain.

18.7 H.P. Compressor Filtration

The H.P. compressor comes standard with triplex filtration. Do **NOT** use any substitute. Change filtration elements every 90,000 cubic feet of air or nitrox processing. If the nitrox system is operated in high humidity and / or high temperature, filter elements must be changed more often. See appendix for details on filter element life factors.

- 1) Shut down the nitrox system
- 2) Open manual bleed drain valve to drain pressure. Leave valve open.
- 3) Unscrew the filter canister cap.
- 4) Remove expended element from filter canister.
- 5) Install new element place pressure on element to seat the element.
- 6) Reinstall cap to canister.
- 7) Close manual condensate valves.

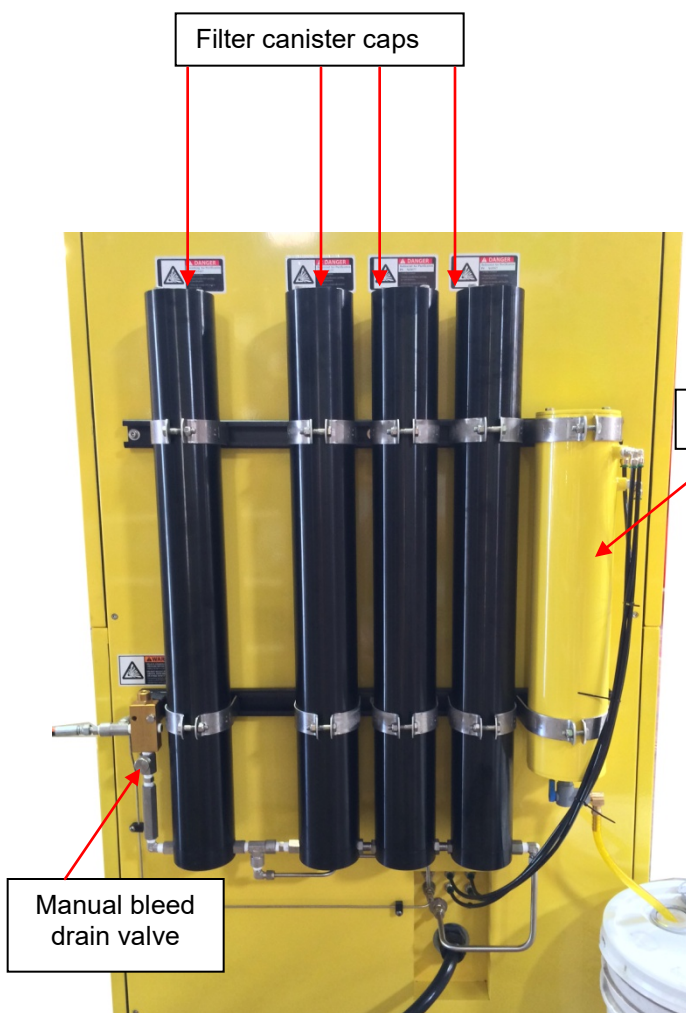

Warning

Be sure that all pressure has been relieved from the system prior to opening any filtration canister. Failure to vent pressure from the system prior to opening the canister can lead to serious personal injury or death.

19.0 Spare Parts List

See L.P. and H.P. compressor manuals for compressor parts lists. Other nitrox system components and related items are listed below.

Nitrox System Components	Type	Part Number
L.P. Compressor Consumables		
Rotary screw compressor lubricant, food grade, nitrox compatible	Nuvair 546, 1 Gal	9409
L.P. filtration elements	Beko	
	Hankison HF7-24	E7-24
	Hankison HF5-24	E5-24
	Hankison HF1-24	E1-24
H.P. Compressor Consumables		
H.P. compressor lubricant, food grade, nitrox compatible	Nuvair 455, 1 Gal	9406
H.P. compressor filtration elements	Gas drying filter	X65677
	Breathing air filter, Grade E	X65247
Heater assembly	1200 Watt, 28" length	H1200
Heater thermostat control	220V Fahrenheit gauge (standard) 220V Centigrade gauge	TS-13020 F TS-13021 C
Heater pressure switch		B16-947
Membrane	230 Series	PPA230
Air intake filter element	10-20 CFM	18P
Mixing tube assembly	1.5 in diameter, specify length	Call for price
Oxygen analyzers	Pro O ₂	9460
	Pro O ₂ Remote	9462
Oxygen sensors	Pro O ₂	9505
	Pro O ₂ Remote	9506
Compressor hose couplers	1-1/4"-1-1/2" to 1-1/4"-1-1/2"	018578000476
	1-1/4"-1-1/2" to 1-1/2"	RDTC40X32
Related Equipment Components		
Air / nitrox quality analysis kit	Specify: (1) CGA Grade required	
	(2) Single use or program Use	

21.0 Appendix

21.1 Supply and Breathing Air Specifications

All supply and breathing air must meet the following requirements of CGA G-7.1-1997. Supply air delivered to the membrane system must be purified to meet oil free Grade D, Grade E, or O.C.A. as specified below and periodic air quality testing to assure compliance is mandatory. All breathing air for diving produced by the downstream compressor must be purified to meet Grade E quality, and periodic air quality testing to assure compliance is mandatory.

Item	Grade D	Grade E	O.C.A
Oxygen	19.5-23.5%	20-22%	20-22%
Carbon Dioxide (maximum)	1000 PPM	1000 PPM	1000 PPM
Carbon Monoxide (maximum)	10 PPM	10 PPM	2 PPM
Hydrocarbons (maximum)	Not specified	25 PPM	25 PPM
Water Vapor (maximum) (3)	67 PPM	67 PPM	67 PPM
Dew Point (maximum) (1)	-50°F	-50°F	-50°F
Oil & Particles (maximum) (2)	5 mg/m3	5 mg/m3	5 mg/m3
Odor	None	None	None

- Notes: (1) Dew Point of supply air must be >10°F (6°C) colder than coldest ambient air expected
 (2) Supply air delivered to the membrane system must contain <0.003 PPM Oil Vapor
 (3) May Vary with intended use.

All breathing nitrox produced for diving must be purified to meet these same requirements, except for oxygen content. Nitrox oxygen content must measure within +/- 1% O₂ of the specified value of the mixture using a properly calibrated oxygen analyzer (i.e. nitrox produced with a target content of 32% O₂ must measure in the range of 31-33% O₂). Periodic air quality testing to assure compliance is mandatory.

21.2 Filter Element Life Factors

Breathing air filter element life is typically rated by manufacturer based on an air temperature of 80°F at the filter inlet. Under normal operation this temperature is 12°F (5°C) warmer than the ambient air, resulting in an equivalent ambient temperature rating at 68°F (20°C).

To determine element life at a different ambient temperature, multiply the rated life by the life factor listed below:

Filter Temperature	Ambient Temperature	Filter Element Life Factor
53°F (12°C)	41°F (5°C)	2.6 x Life
62°F (17°C)	50°F (10°C)	1.8 x Life
71°F (23°C)	59°F (16°C)	1.35 x Life
80°F (27°C)	68°F (20°C)	1 x Life
89°F (32°C)	77°F (25°C)	0.8 x Life
96°F (36°C)	84°F (29°C)	0.55 x Life
105°F (41°C)	93°F (34°C)	0.45 x Life
114°F (46°C)	102°F (39°C)	0.35 x Life

Material Safety Data Sheets

Nuvair™ 455 Premium Synthetic Food Grade Air/nitrox compressor lubricant

Effective Date: 03/19/2010

I. Product Identification:

Trade Name: Nuvair 455
 Chemical Name: Polyalphaolefin
 Chemical Family: Synthetic hydrocarbons/Esters

II. Components & Hazard Statement:

This product is non-hazardous. This material is not considered hazardous by the OSHA Hazard Communication Standard (29 CFR 1910.1200).

III. Physical Data:

Viscosity: 100 cst. @40°C
 Specific Gravity (Water = 1.0): 0.85
 Boiling Point: N.A.
 Vapor Pressure: Negligible
 Appearance & Odor: Clear – with mild odor
 Solubility in Water: Negligible

IV. Fire & Explosion Hazard Data:

Flash point: 464°F / 24°C/ COC
 Auto ignition Temperature: Not Established
 Flammability Limits: Not Established
 Extinguishing Media: Dry Chemical; CO2 Foam; Water Spray
 Special Fire Fighting Procedure: Burning may produce irritating/noxious fumes. Firefighters should use NIOSH/MNSA approved self-contained breathing apparatus. Use water to cool fire-exposed containers to prevent pressure build-up.

V. Reactivity Data:

Stability: This product is stable and will not react with water.
 Materials to Avoid: Avoid contact with strong oxidizing agents, strong acids and strong alkalis.
 Hazardous Decomposition Products: None under normal use.

VI. Health Information:

Eye Contact: Flush eyes with water for 15 minutes. Call physician if irritation develops.
 Skin Contact: Wash skin with soap and water.
 Inhalation: Remove to fresh air.
 Ingestion: First aid not normally required. If uncomfortable, call physician.

VII. Health Hazard Data:

Exposure Limit: Not Applicable
 Effects of Overexposure: Low oral and dermal toxicity. Prolonged or repeated exposure may cause irritation, nausea, and vomiting.

VIII. Employee Protection:

For general personal hygiene, wash hands thoroughly after handling material. Avoid contact with skin and eyes. Chemical impervious gloves are not required, but may be recommended for prolonged exposure. Use in a well ventilated area.

IX. storage, Spill, & Disposal Procedures:

storage: Store in clean, dry area.
 Spills: Use absorbent materials to soak up fluid.
 Disposal: Incinerate this product and all associated wastes in a licensed facility in accordance with Federal, state, and local regulations.

X. Hazard Rating Information:

NFPA Health: 0
 Flammability: 1
 Reactivity: 0
 Personal Protection: B

This information contained herein is based on the data available to us and is believed to be true and accurate. Nuvair makes no warranty, expressed or implied, regarding the accuracy of this data or the results to be obtained from the use thereof. Nuvair assumes no responsibility for injury from the use of this product.

Material Safety Data Sheet

Nuvair™ 751 Premium Synthetic Diester Based Air/nitrox compressor lubricant

Effective Date: 3/10/2010

Supercedes:

I. Product Identification:

Trade Name: Nuvair 751
 Chemical Name: Diester
 Chemical Family: Diester

II. Components & Hazard Statement:

This product is non-hazardous. This material is not considered hazardous by the OSHA Hazard Communication Standard (29 CFR 1910.1200).

III. Physical Data:

Viscosity: 146 cst. @40°C
 Specific Gravity (Water = 1.0): 0.94
 Boiling Point: Not determined
 Vapor Pressure: Negligible
 Appearance & Odor: Amber / mild odor
 Solubility in Water: Negligible
 Other Data: Non-toxic USDA H-2 approved

IV. Fire & Explosion Hazard Data:

Flash point: 520°F / 271°C COC ASTM D-92
 Autoignition Temperature: 765°F ASTM D-2155
 Flammability Limits: Not Established
 Extinguishing Media: Dry Chemical; CO2 Foam; Water Spray
 Special Fire Fighting Procedure: Burning may produce irritating/noxious fumes. Firefighters should use NIOSH/MNSA approved self-contained breathing apparatus. Use water to cool fire-exposed containers to prevent pressure build-up.

V. Reactivity Data:

Stability: Stable under normal conditions.
 Materials to Avoid: Avoid contact with strong oxidizing agents, strong acids and strong alkalis.
 Hazardous Decomposition Products: None under normal use.

VI. Health Information:

Eye Contact: Flush eyes with water for 15 minutes. Call physician if irritation develops.
 Skin Contact: Wash skin with soap and water.
 Inhalation: Remove to fresh air.
 Ingestion: First aid not normally required. If uncomfortable, call physician.

VII. Health Hazard Data:

Exposure Limit: Not Applicable
 Effects of Overexposure: Low oral and dermal toxicity. Prolonged or repeated exposure may cause irritation, nausea, and vomiting.

VIII. Employee Protection:

For general personal hygiene, wash hands thoroughly after handling material. Avoid contact with skin and eyes. Chemical impervious gloves are not required, but may be recommended for prolonged exposure. Use in a well ventilated area.

IX. storage, Spill, & Disposal Procedures:

storage: Store in clean, dry area.
 Spills: Use absorbent materials to soak up fluid.
 Disposal: Incinerate this product and all associated wastes in a licensed facility in accordance with Federal, state, and local regulations.

X. Hazard Rating Information:

NFPA Health: 0
 Flammability: 1
 Reactivity: 0
 Personal Protection: B

This information contained herein is based on the data available to us and is believed to be true and accurate. Nuvair makes no warranty, expressed or implied, regarding the accuracy of this data or the results to be obtained from the use thereof. Nuvair assumes no responsibility for injury from the use of this product.

Material Safety Data Sheet

Nuvair™ 546 Premium Synthetic Food Grade Air/nitrox compressor lubricant

Effective Date: 03/19/2010

Supersedes:

I. Product Identification:

Trade Name: Nuvair 546
 Chemical Name: Polyalphaolefin
 Chemical Family: Synthetic hydrocarbon

II. Components & Hazard Statement:

This product is non-hazardous. This material is not considered hazardous by the OSHA Hazard Communication Standard (29 CFR 1910.1200)

III. Physical Data:

Viscosity: 46 cSt. @ 40 □ C
 Specific Gravity (Water = 1.0): 0.84
 Boiling Point: Not Determined
 Vapor Pressure: Negligible
 Appearance & Odor: Clear & odor mild
 Solubility in Water: Negligible
 Other Data: Non-Toxic USDA H-1 Approved

IV. Fire & Explosion Hazard Data:

Flash point: 500°F / 260°C
 Autoignition Temperature: Not Determined
 Flammability Limits: Not Determined
 Extinguishing Media: Dry Chemical; CO2 Foam; Water Spray
 Special Fire Fighting Procedure: Burning may produce irritating/noxious fumes. Firefighters should use NIOSH/MNSA approved self-contained breathing apparatus. Use water to cool fire-exposed containers to prevent pressure build-up.

V. Reactivity Data:

Stability: Stable under normal conditions.
 Materials to Avoid: Avoid contact with strong oxidizing agents, strong acids and strong alkalis.
 Hazardous Decomposition Products: None under normal use.

VI. Health Information:

Eye Contact: Flush eyes with water for 15 minutes. Call physician if irritation develops.
 Skin Contact: Wash skin with soap and water.
 Inhalation: Remove to fresh air.
 Ingestion: First aid not normally required. If uncomfortable, call physician.

VII. Health Hazard Data:

Exposure Limit: Not Applicable
 Effects of Overexposure: Low oral and dermal toxicity. Prolonged or repeated exposure may cause irritation, nausea, and vomiting.

VIII. Employee Protection:

For general personal hygiene, wash hands thoroughly after handling material. Avoid contact with skin and eyes. Chemical impervious gloves are not required, but may be recommended for prolonged exposure. Use in a well ventilated area.

IX. storage, Spill, & Disposal Procedures:

storage: Store in clean, dry area.
 Spills: Use absorbent materials to soak up fluid.
 Disposal: Incinerate this product and all associated wastes in a licensed facility in accordance with Federal, state, and local regulations.

X. Hazard Rating Information:

NFPA Health: 0
 Flammability: 1
 Reactivity: 0
 Personal Protection: B

This information contained herein is based on the data available to us and is believed to be true and accurate. Nuvair makes no warranty, expressed or implied, regarding the accuracy of this data or the results to be obtained from the use thereof. Nuvair assumes no responsibility for injury from the use of this product.

OWNER'S WARRANTY RESPONSIBILITIES

Failure of the owner to prevent equipment damage by complying with the procedures outlined below and in the operation manual will void the nitrox system warranty.

Installation:

- All set up requirements and procedures provided in the nitrox system operation manual must be followed in their entirety including supply air cleanliness, compressor preparation, and installation of the nitrox system.
- Supply air to the membrane must be properly filtered to oil free CGA Grade D air quality or better to prevent damage to the membrane. Air quality testing of the supply air should be performed periodically and documented to assure compliance.
- If there is any doubt regarding the suitability of a H.P. or L.P. compressor for compressing nitrox, contact Nuair or the compressor manufacturer before you connect your nitrox system.
- If an existing H.P. or L.P. compressor is to be used for compressing nitrox, all traces of the old lubricant must be removed and replaced with a nitrox compressor lubricant approved by Nuair.
- Electrical wiring and connections should be made by a qualified electrician in accordance with all national and local electrical codes.
- Do not change the temperature setting on the heater thermostat control. Changes in temperature settings may cause membrane damage.
- To prevent compressor damage, only use the compressor Intake Hose provided. If a longer hose is required, contact Nuair for assistance.
- Compressors must be provided adequate ventilation to operate properly and prevent heat damage. This requires an ambient temperature below 104 °F (40 °C), sufficient clearance from adjacent walls, and proper rotation direction.

Operation:

- Do not use the nitrox system to supply a H.P. or L.P. compressor with nitrox mixtures containing more than 40% oxygen. Compressing higher concentrations of oxygen may cause severe compressor damage.
- Do not pump nitrox mixtures at pressures above the compressor manufacturer's rating, and never above 3600 P.S.I. (250 bar). Compressing nitrox at higher pressures may cause severe H.P. compressor damage.
- To prevent membrane damage, drain all low pressure filters and condensate tanks on a daily basis.
- If you become aware of an operational fault, stop using the equipment immediately and contact Nuair for assistance.

Maintenance:

- Change low pressure filter elements on a schedule determined by filter capacity and ambient temperature and humidity. Contact Nuair if you need assistance establishing a schedule for your equipment and location.
- Replace membrane system air intake filter on a regular basis to prevent flow obstruction.
- Keep all nuts, bolts, fittings, connectors, and clamps tight.
- Keep a service record book showing that regular maintenance work has been carried out. If a warranty claim becomes necessary, it will aid in demonstrating that damage has not been caused by insufficient maintenance. Proof of maintenance may be required prior to determining the validity of a warranty request.

NUVAIR NITROX SYSTEM WARRANTY

NUVAIR extends a limited warranty, which warrants the nitrox system to be free from defects in materials and workmanship under normal use and service for a limited period. The specific membrane component of the nitrox system is warranted according to the pro-rated terms as set forth below. All other Original Equipment Manufacturer (OEM) components used in the system are warranted only to the extent of the OEM's warranty to NUVAIR. NUVAIR makes no warranty with respect to these OEM components, and only warrants the workmanship that NUVAIR has employed in the installation or use of any OEM component. This warranty is not transferable.

NUVAIR will, at its discretion and according to the terms as set forth within, replace or repair any materials which fail under normal use and service and do not exhibit any signs of improper maintenance, misuse, accident, alteration, weather damage, tampering, or use for any other than the intended purpose. Determination of failure is the responsibility of NUVAIR, which will work together with the customer to adequately address warranty issues. When any materials are repaired or replaced during the warranty period, they are warranted only for the remainder of the original warranty period. This warranty shall be void and NUVAIR shall have no responsibility to repair or replace damaged materials resulting directly or indirectly from the use of repair or replacement parts not approved by NUVAIR.

Pro-Rated Terms:

NUVAIR warrants the membrane component of the nitrox system to be free from defects in material and workmanship for a period of thirty-six (36) months from date of installation or forty-two (42) months from date of shipment by NUVAIR, whichever may occur first. The warranty covers parts only and is prorated as follows:

- First Year Repair or replacement free of charge
- Second Year Warranty allowance of 70% of the current membrane component list price
- Third Year Warranty allowance of 40% of the current membrane component list price

A warranty registration card, supplied with system documentation, must be filled out and submitted to NUVAIR for the warranty to be in full effect. If the warranty registration card is not received within thirty (30) days of installation, the thirty-six (36) month warranty will begin with the date of shipment from NUVAIR. For warranty service to be considered, customer's account must be current or paid in full.

Maintenance Items:

Any materials which are consumed, or otherwise rendered not warrantable due to processes applied to them, are considered expendable and are not covered under the terms of this policy. This includes maintenance and consumable items listed as part of a suggested maintenance program included with system documentation.

Return Policy:

Application for warranty service can be made by contacting NUVAIR during regular business hours and requesting a Return Material Authorization (RMA) number. Materials that are found to be defective must be shipped, freight pre-paid, to the NUVAIR office in Oxnard, California. Upon inspection and determination of failure, NUVAIR shall exercise its options under the terms of this policy. Warranty serviced materials will be returned to the customer via NUVAIR's preferred shipping method, at NUVAIR's expense. Any expedited return shipping arrangements to be made at customer's expense must be specified in advance.

Limitation of Warranty and Liability:

Repair, replacement or refund in the manner and within the time provided shall constitute NUVAIR'S sole liability and the Purchaser's exclusive remedy resulting from any nonconformity or defect. NUVAIR shall not in any event be liable for any damages, whether based on contract, warranty, negligence, strict liability or otherwise, including without limitation any consequential, incidental or special damages, arising with respect to the equipment or its failure to operate, even if NUVAIR has been advised of the possibility thereof. NUVAIR makes no other warranty or representation of any kind, except that of title, and all other warranties, express or implied, including warranties of merchantability and fitness for a particular purpose, are hereby expressly disclaimed. No salesman or other representative of NUVAIR has authority to make any warranties.

Additional Record of Changes

It is the responsibility of the owner of this product to register their ownership with Nuvair by sending the warranty card provided to Nuvair. This card is to establish registration for any necessary warranty work and as a means of communication that allows Nuvair to contact the user regarding this product.

The user must notify Nuvair of any change of address by the user or sale of the product. All changes or revisions to this manual must be recorded in this document to ensure that the manual is up to date.

Change Date	Description of Change

NOTES:

Intentionally left blank

NOTES:

Intentionally left blank



Nuvair™
Phone 1-805-815-4044
Fax 1-805-486-0900
1600 Beacon Place
Oxnard, CA 93033 USA
Email : info@nuvair.com
Web : www.nuvair.com

Revision 8.20