

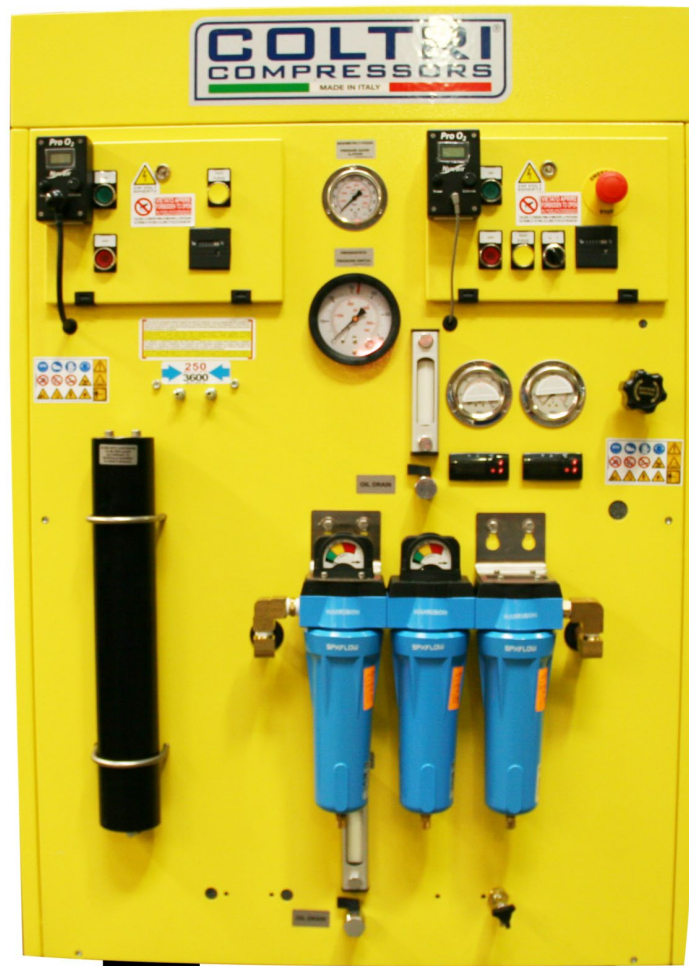

Operation Manual
Nuvair Voyager I Nitrox System
with CO2 Scrubber



If you have any questions on this equipment, please contact Technical Support at:

Nuvair
1600 Beacon Place
Oxnard, CA 93033 USA

Phone: +1.805.815.4044
Fax: +1.805.486.0900
Email: info@Nuvair.com

Hours: Monday through Friday
8:00 AM to 5:00 PM Pacific Time



WARNING

This Operation Manual contains important safety information and should always be available to those personnel operating this equipment. Read, understand, and retain all instructions before operating this equipment to prevent injury or equipment damage.

Every effort was made to ensure the accuracy of the information contained within. Nuvair, however, retains the right to modify its contents without notice.

Under Nuvair's system of continuous improvement, certain components may be updated or changed as higher quality or more efficient parts and assemblies become available.

Nuvair will make every effort to update manuals as parts and functional aspects change. However, the look or location of components on your product may differ from those in this manual if improvements have been made that do not affect functionality or operational procedures.

Units pictured may also be equipped with different options than those on your product. In this case, the basic operational and maintenance guidelines will still apply.

If you have problems or questions after reading the manual, stop and call Nuvair at +1.805.815.4044 for information.

Table of Contents

Introduction

1.0 Introduction 4
 2.0 Safety Warnings 5
 3.0 Safety and Operation Precautions 7
 4.0 Legal Precautions 8
 5.0 Theory of Operation 9
 6.0 Low Pressure Air Compressor Technical Data 10
 7.0 High Pressure Compressor Technical Data 11
 8.0 System Components 12
 9.0 Nitrox System Specifications 13
 10.0 Nitrox System Component Identification 14
 11.0 System Drawing/Schematic 15
 12.0 System Flow Chart 16

Setup, Operation, and Maintenance

13.0 Installing the Nitrox System 17
 13.1 Precautions 18
 13.2 Attaching Nitrogen Discharge Hose (Optional) 18
 13.3 Electrical Power Connection 19
 13.4 Air/Nitrox Quality Testing 19
 14.0 Pre-Operation Instructions 20
 14.1 Compressor Lubricant Levels 20
 14.2 Membrane System Feed Air Regulator and Switch 20
 14.3 Oxygen Analyzer Calibration 21
 14.4 Attaching Scuba Cylinder 23
 15.0 Producing Nitrox 24
 15.1 Flow to Membrane 24
 15.2 Setting Proper Pressure 26
 15.3 Final Adjustments Before Pumping Nitrox 26
 15.4 Pumping Nitrox 27
 15.5 Pumping Air 29
 15.6 Shutting Down 29
 16.0 Nitrox Operational Notes 30
 16.1 Correlation of Feed Air Pressure to Oxygen Content 30
 16.2 Hot Fills 30
 17.0 Maintenance 31
 17.1 Daily Maintenance 31
 17.2 Routine Maintenance 31
 17.3 Compressor Lubricant 33
 17.4 LP Feed Air Filtration 34
 17.5 HP Compressor Filtration 36
 17.6 Spare Parts List 37
 17.7 Service Record Log 38

Appendix

Supply and Breathing Air Specifications 39
 Filter Element Life Factors 39
 CO₂ Scrubber Guide 40
 Owner's Warranty Responsibilities 41
 Warranty 42

Separate Manuals Included:

- Nuvair Pro O₂ Oxygen Analyzer Operation Manual
- Champion R15 Compressor Manual
- High Pressure Compressor Manual

1.0 Introduction

This manual will assist you in the proper set-up, operation and maintenance of the Nuvair Voyager nitrox system. Be sure to read the entire manual.

Throughout this manual we will use certain words to call your attention to conditions, practices or techniques that may directly affect your safety. Pay particular attention to information introduced by the following signal words:



Indicates an imminently hazardous situation, which if not avoided, will result in serious personal injury or death.



Indicates a potentially hazardous situation, which if not avoided, could result in serious personal injury or death.



Indicates a potentially hazardous situation, which if not avoided, may result in minor or moderate injury. It may also be used to alert against unsafe practices.



Notifies people of installation, operation or maintenance information which is important but not hazard-related.

2.0 Safety Warnings

Nuvair has taken extreme care in providing you with the information you will need to operate this system. However, it is up to you to carefully read this manual and make the appropriate decisions about system safety.



WARNING

This equipment is used to provide breathing gas for the purpose of underwater life support. Read this manual in its entirety. Failure to heed the warnings and cautions contained in this document may result in severe injury or death.



WARNING

The equipment you will be using to manufacture Nitrox (oxygen rich air) will expose you to both low and high-pressure gas. Gas, even under moderate pressures, can cause extreme bodily harm. Never allow any gas stream to be directed at any part of your body.



WARNING

Any pressurized hose can cause extreme harm if it comes loose or separates from its restraint (or termination) while under pressure and strikes any part of your body. Use appropriate care in making and handling all gas connections.



DANGER

Pure nitrogen is a colorless, odorless, tasteless gas that will not support life. Breathing gas mixtures containing more than 84% nitrogen at surface pressures will lead to unconsciousness and may cause death.



WARNING

The nitrogen discharge from the Membrane System must be vented to the exterior of any closed building, boat, or similar enclosed space. Breathing gas mixtures containing more than 84% nitrogen at surface pressure will lead to unconsciousness and may cause death.



WARNING

Do not use any form of mineral oil or synthetic lubricant not rated for Nitrox in any Compressor in this system. Use only the recommended Nitrox Compressor Lubricant. Never mix the Nitrox Compressor Lubricant with other lubricants. Remove all existing lubricant and replace with the proper Nitrox Compressor Lubricant prior to installing the Membrane System. The use of improper lubricants can lead to fire or explosions, which may cause serious personal injury or death.



WARNING

Do not use this system to produce Nitrox mixtures containing more than 40% oxygen. Pumping Nitrox mixtures with higher concentrations of oxygen may lead to fires or explosions, which can cause serious personal injury or death.



WARNING

The use of enriched air Nitrox does not eliminate the risk of decompression sickness (DCS) in diving. Decompression sickness can lead to permanent disability or death.



WARNING

Do not pump Nitrox mixtures at pressures above the HP Compressor manufacturer's rating, and never above 3600 PSI (250 bar). The system is not rated for pressures above 3600 psi (250 bar). Higher pressures may lead to explosions which may cause serious personal injury or death.



CAUTION

Ambient room temperature should never exceed 100°F (38°C) during operation of the Nitrox System. Operation at higher temperatures may lead to system damage and malfunction. A damaged membrane will not produce the correct Nitrox mixture which can lead to severe personal injury if the gas is used for diving purposes without proper analysis.

3.0 Safety And Operation Precautions

Because a compressor is a piece of machinery with moving and rotating parts, the same precautions should be observed as with any piece of machinery of this type where carelessness in operations or maintenance is hazardous to personnel. In addition to the many obvious safety precautions, those listed below must also be observed:

- 1) Read all instructions completely before operating any compressor or Nitrox System.
- 2) For installation, follow all local electrical and safety codes, as well as the National Electrical Code (NEC) and the Occupational Safety and Health Administration (OSHA) standards.
- 3) Electric motors must be securely and adequately grounded. This can be accomplished by wiring with a grounded, metal-clad raceway system to the compressor starter; by using a separate ground wire connected to the bare metal of the motor frame; or other suitable means.
- 4) Protect all power cables from coming in contact with sharp objects. Do not kink power cables and never allow the cables to come in contact with oil, grease, hot surfaces, or chemicals.
- 5) Make certain that power source conforms to the requirements of your equipment.
- 6) Pull main electrical disconnect switch and disconnect any separate control lines, if used, before attempting to work or perform maintenance. "Tag Out" or "Lock Out" all power sources.
- 7) Do not attempt to remove any parts without first relieving the entire system of pressure.
- 8) Do not attempt to service any part while System is in an operational mode.
- 9) Do not operate the System at pressures in excess of its rating.
- 10) Do not operate compressor at speeds in excess of its rating.
- 11) Periodically check all safety devices for proper operation. Do not change pressure setting or restrict operation in any way.
- 12) Be sure no tools, rags or loose parts are left on the Nitrox System.
- 13) Do not use flammable solvents for cleaning the Air Inlet Filters or elements and other parts.
- 14) Exercise cleanliness during maintenance and when making repairs. Keep dirt away from parts by covering parts and exposed openings with clean cloth or Kraft paper.
- 15) Do not operate the compressor without guards, shields, and screens in place.
- 16) Do not install a shut-off valve in the compressor discharge line, unless a pressure relief valve, of proper design and size, is installed in the line between the compressor unit and shut-off valve.
- 17) Do not operate in areas where there is a possibility of inhaling carbon monoxide, carbon dioxide, nitrogen, or flammable or toxic fumes.
- 18) Be careful when touching the exterior of a recently run electric, gasoline, or diesel motor - it may be hot enough to be painful or cause injury. With modern motors this condition is normal if operated at rated load - modern motors are built to operate at higher temperatures.
- 19) Inspect unit daily to observe and correct any unsafe operating conditions found.
- 20) Do not "play around" with compressed air, nor direct air stream at body, because this can cause injuries.
- 21) Compressed air from this machine absolutely must not be used for food processing or breathing air without adequate downstream filters, purifiers and controls and periodic air quality testing.
- 22) Always use an air pressure-regulating device at the point of use, and do not use air pressure greater than marked maximum pressure.
- 23) Check hoses for weak or worn conditions before each use and make certain that all connections are secure.

The user of any compressor or Nitrox System manufactured by Nuvair is hereby warned that failure to follow the preceding Safety and Operation Precautions can result in injuries or equipment damage. However, Nuvair does not state as fact or does not mean to imply that the preceding list of Safety and

Operation Precautions is all-inclusive, and further that the observance of this list will prevent all injuries or equipment damage.

4.0 Legal Precautions

It is highly recommended that a Nitrox fill log be maintained when filling Scuba cylinders to document the following information. This log must be of permanent binding style with no loose pages.

- ◆ Fill date and time of day
- ◆ Tank Number
- ◆ Supplier's check of oxygen content (%O₂) plus signature and date
- ◆ User's check of oxygen content (%O₂) plus signature and date
- ◆ Fill Pressure
- ◆ MOD (Maximum Operating Depth) in user's handwriting
- ◆ Nitrox certifying agency and card number

5.0 Theory of Operation

The Voyager Nitrox System is a turnkey package that produces oxygen-rich air (Nitrox) and then compresses it with a High Pressure (HP) Compressor to fill Scuba Tanks or storage cylinders. The package is designed to be fully automatic, with a quieted enclosure for noise reduction and protection from moving parts while it is running. Although it is described as the “Nitrox Compressor”, it can also be used to pump air.

The Nitrox System allows for efficient and cost effective Nitrox production using electric power, without the hazards or expense of blending with stored high-pressure oxygen (O₂). Instead, the system uses a Semi-Permeable Membrane to produce Nitrox from air. A portion of the nitrogen in air is separated out, leaving an oxygen rich Nitrox mixture.

The Voyager uses a Reciprocating Piston LP Compressor, Air Aftercooler, Volume Tank, and Filtration to provide the Membrane System with a source of clean, pressurized feed air for separation. The air is filtered to CGA Grade D or better air quality prior to entering the Membrane System so it will not damage or plug the Membrane fibers. Specifications for Grade D air are provided in the Appendix.

The Voyager’s Membrane System is rated for a maximum feed air pressure of 300 PSI (21 bar) and has been configured to work well with the 175 P.S.I (12 bar) maximum pressure delivered by the LP Compressor. A Feed Air Pressure Regulator reduces the pressure to appropriate levels for various %O₂ Nitrox production. The air is then heated to a temperature that provides stability over a wide range of ambient conditions, is optimal for Membrane permeation, and prevents moisture condensation.

The heated air enters the Membrane, which is made up of thousands of miniature hollow fibers. The walls of these fibers are semi-permeable and designed for different gases to move through them (or permeate) at different speeds. The resulting gas mixture is known as the “permeate”. As air flows through the hollow fibers, both oxygen and nitrogen permeate through the fiber walls. The oxygen permeates faster than the nitrogen, which produces permeate with an oxygen content greater than air. The gas that reaches the end of the hollow fibers without permeating is almost entirely nitrogen and is discharged. The flow rate of this discharge is set by the factory via a fixed orifice, which controls the permeate to contain a constant 44% O₂ under normal operating conditions.

The permeate is a concentrated mixture that must be diluted with additional air prior to entering the HP Compressor. It exits the Membrane at ambient to slightly negative pressure and travels into the Mixing Tube, where it mixes homogeneously with filtered outside air. The amount of dilution, and thus final %O₂, is obtained by adjusting the Feed Air Pressure Regulator. As pressure is increased, permeate flow increases, air flow decreases, and a higher %O₂ Nitrox is produced. As pressure is decreased, permeate flow decreases, air flow increases, and a lower %O₂ Nitrox is produced.

This relationship between permeate flow and air flow exists because the total of these two flow rates will always equal the intake flow rate demanded by the HP Compressor. The resulting Nitrox mixture is analyzed for %O₂ before entering the HP Compressor for approximate content and again when pumping Nitrox for precise content. The HP Compressor pumps the Nitrox to a maximum pressure of 3600 psi (250 bar) to fill Scuba Tanks or storage cylinders.

A unique feature of Nuvair Nitrox Systems is that the feed air pressure that correlates to a specific Nitrox %O₂ is repeatable. For example, if your HP Compressor pumps 36% O₂ when the feed air pressure is at 125 PSI (9 bar), then adjusting the Feed Air Pressure Regulator to 125 PSI (9 bar) during the next use will produce the same mixture.

6.0 Low Pressure Compressor Technical Data

Capacity and Power Consumption:

- Normal working pressure – 165-175 PSI (11-12 bar)
- Capacity at normal working pressure – 23.5 cfm (666 L/min) Delivery
- 29.9 cfm (847 L/min) Displacement
- Compressor speed of rotation – 1035 rpm
- Maximum working pressure – 175 psi (12 bar)
- Transmission – Belt drive

Cooling

- Allowed ambient temperature – 32-100°F (0-38°C)
- Aftercooler heat rejection – outlet air temperature reduced to within 20°F (11°C) of ambient

Motor and Electrical Values:

- Motor - F class, IP55, 7.5hp 3 phase or 5.5hp Single phase
- Speed of rotation – 1725 rpm
- Compressor current 230V-50/60 Hz/single phase – 24A
 230V-50/60 Hz/three phase – 20A

General Technical Data:

- Oil Quantity – 2 qt. (1.9 liters)

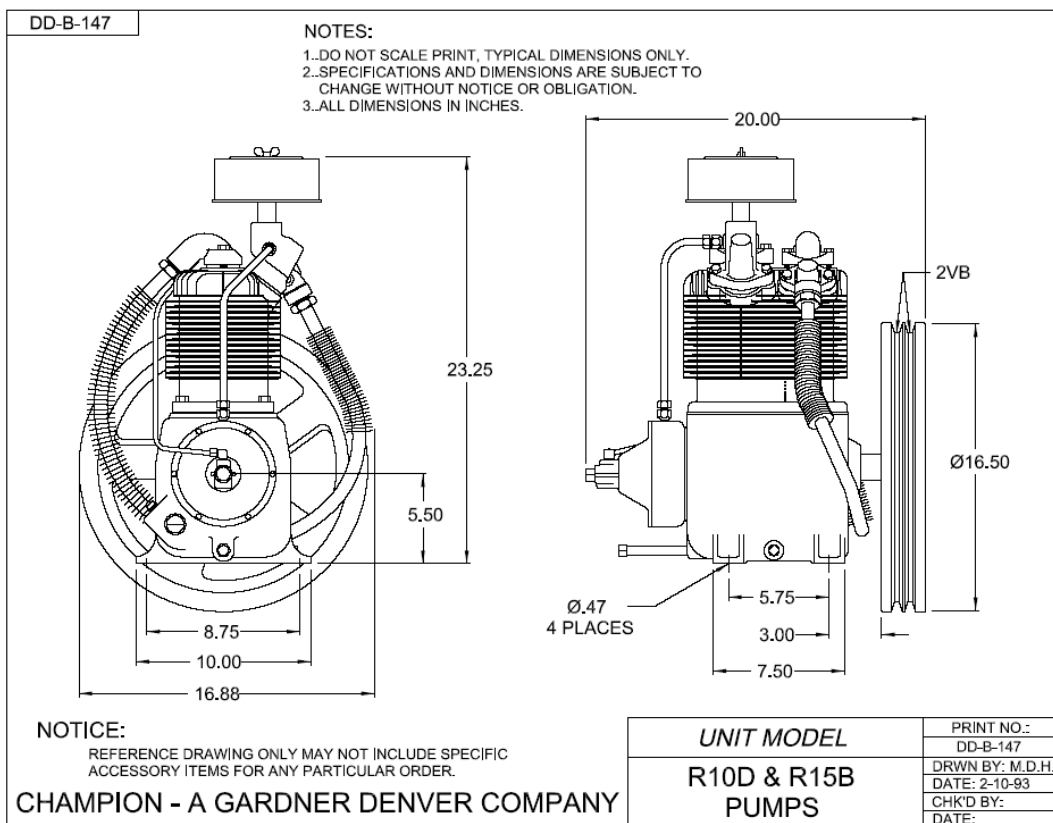

7.0 High Pressure Compressor Technical Data

Capacity and Power Consumption:

- Normal working pressure – 3600 PSI (250 bar)
- Charging Rate - 9 SCFM (255 L/min)
- Compressor speed of rotation – 1550 rpm
- Maximum working pressure – 5000 psi (354 bar)
- Transmission – Belt drive

Cooling:

- Allowed ambient temperature – 32-105°F (0-40°C)
- Air Cooled Interstage & Aftercooler

Motor and Electrical Values:

- Motor - 7.5hp 3 phase or 5.5hp Single phase
- Speed of rotation – 3450 rpm
- Compressor current
 - 208-230V / E1 / 60Hz – 56.4A
 - 208-230V / E3 / 60Hz – 50.1A
 - 440-480V / E3 / 60Hz – 27.0A
 - 208-230V / E3 / 50Hz – 43.1A
 - 380-415V / E3 / 50Hz – 32.0A

General Technical Data:

- Number Of Stages - 3
- Number Of Cylinders – 3
- Lubrication – Splash Lubricated
- Oil Quantity – 1.6 qt. (1.5 liters)
- HP Filtration Rating – CGA Grade E, 13,000 cu ft at 68°F (20°C)
- Condensate Drains – Automatic & Manual Interstage & Final
- Fill Pressure Stop – Automatic & Manual
- Low Oil Level Shutdown – Optional
- High Temperature Shutdown – Optional
- Interstage Pressure Gauges – Optional

8.0 System Components

- Low Pressure Compressor, including:
 - ◆ Push Button Magnet Motor Starter
 - ◆ Hour Meter
 - ◆ External Lubricant Sight Gauge, Fill, and Drain
 - ◆ Nuvair 455 Food Grade Compressor Lubricant
- Low Pressure Volume Tank:
 - ◆ 15 Gallon Vertical Mount standard, other remote configurations available
 - ◆ Automatic Condensate Drain
- Volume Tank Pressure Gauge
- Solenoid Powered Feed Air On/Off Valve
- Low Pressure>Low Pressure Feed Air Regulator with Pressure Gauge:
 - ◆ Pressure input to regulator 165-175 psi (11-12 bar)
 - ◆ Output Pressure from regulator 90-165 psi (6-11 bar) depending on Nitrox %O₂
- Low Pressure Feed Air Filtration, Grade D Breathing Air, including three stages:
 - ◆ Coalescing & Particle Removal to 1 micron, auto drain, liquid level indicator
 - ◆ Water & Oil Vapor Removal to 0.01 micron, auto drain, liquid level & service life indicators
 - ◆ Oil Vapor Removal to 0.003 PPM
- Heater including:
 - ◆ Thermostat Control
 - ◆ Digital Temperature Gauge
 - ◆ Pressure Switch
 - ◆ 200 PSI (14 bar) ASME Over Pressure Relief
- Semi-Permeable Membrane
- Mixing Tube & Air Intake Filter
- Nuvair Pro O₂ Remote Permeate Oxygen Analyzer
- Nitrogen Discharge Hose (optional)
- Nuvair Pro O₂ Fill Oxygen Analyzer, including:
 - ◆ High Pressure>Low Pressure Regulator
 - ◆ Flow Restrictor, 1 - 5 L/min
- High Pressure Compressor, including
 - ◆ Push Button Magnet Motor Starter
 - ◆ Hour Meter
 - ◆ Automatic Condensate Drains
 - ◆ Automatic Fill Pressure Stop
 - ◆ External Lubricant Sight Gauge, Fill, and Drain
 - ◆ Nuvair 455 Food Grade Compressor Lubricant
- High Pressure Filtration, Grade E Breathing Air
- (2) Five Foot Fill Whips with International Yoke & Valve
- Air/Nitrox Quality Analysis Kit

9.0 Nitrox System Specifications

LP Compressor	Delivery @ 175 PSI (12 bar)	23.5 cfm FAD (666 L/min)
	Horsepower – Electric	7.5 hp (5.5 kW)
Physical Specifications	Height	52 in (132 cm)
	Width	38 in (97 cm)
	Depth	49 in (125 cm)
	Weight	840 lb (382 kg)
Full Load Amps	208-230V/E1/60Hz	56.4
	208-230V/E3/60Hz	50.1
	440-480V/E3/60Hz	27.0
	208-230V/E3/50Hz	43.1
	380-415V/E3/50Hz	32.0
Membrane Input	Operating Pressure Range	90-165 psi (6-11 bar)
	Maximum Input Pressure	300 psi (21 bar)
	Feed Air Volume Range	8-23.5 scfm (212-666 L/min)
	LP Feed Air Quality	Grade D
	Optimum Temperature	110 +/- 5°F (43 +/- 3°C)
EANx	Nitrox %O₂ Range	24 - 40%
HP Compressor	Charging Rate	9 SCFM (255 L/min)
	Horsepower – Electric	7.5 hp (5.5 kW)
Cooling	Allowed Ambient Temperature	32-100°F (0-38°C)
	Aftercooler Heat Rejection	Outlet temp within 20°F (11°C) of ambient temp

10.0 Nitrox System Component Identification

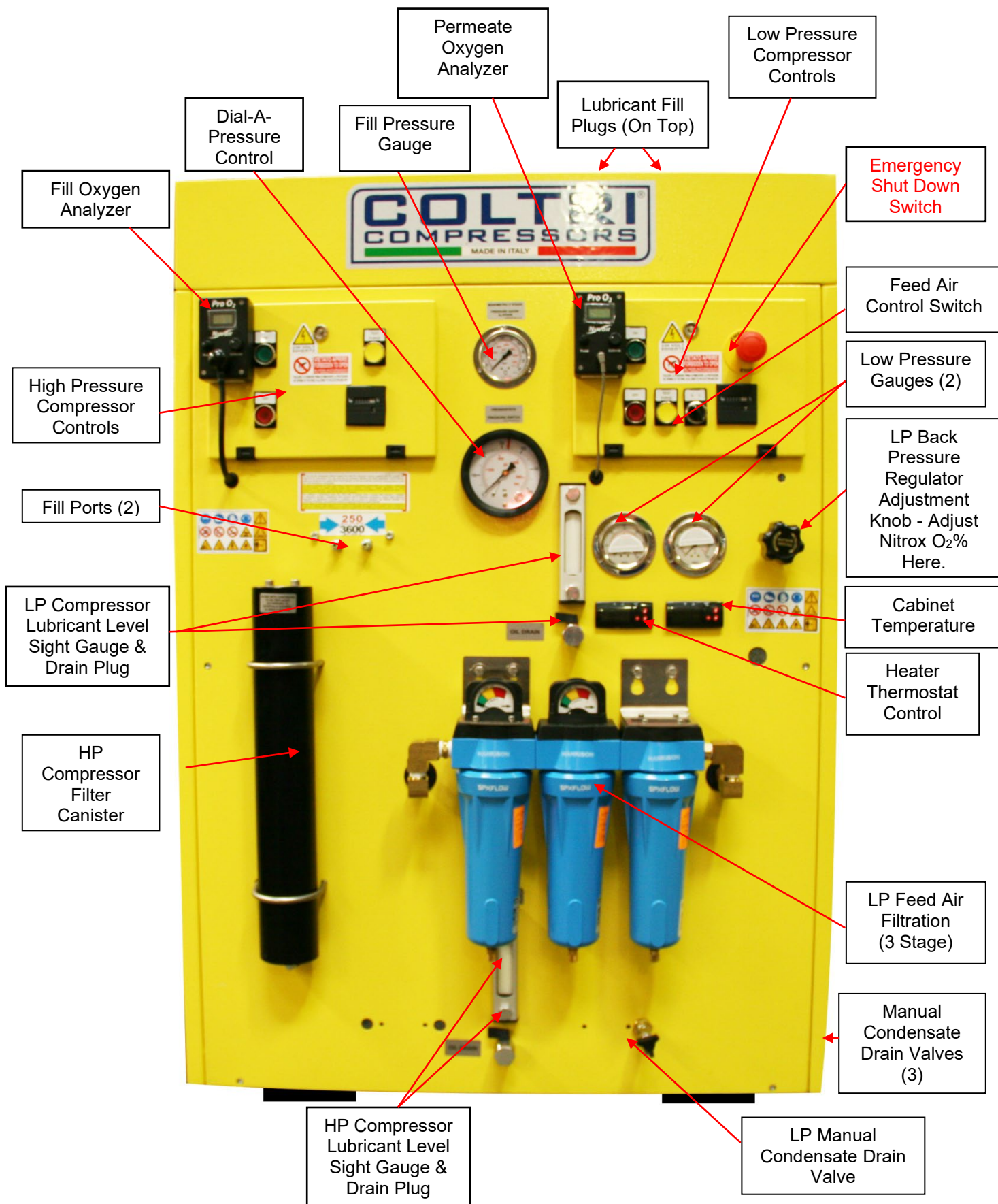

Permeate Oxygen Analyzer

Low Pressure Compressor Controls

Dial-A-Pressure Control

Fill Pressure Gauge

Lubricant Fill Plugs (On Top)

Emergency Shut Down Switch

Fill Oxygen Analyzer

Feed Air Control Switch

High Pressure Compressor Controls

Low Pressure Gauges (2)

Fill Ports (2)

LP Back Pressure Regulator Adjustment Knob - Adjust Nitrox O₂% Here.

LP Compressor Lubricant Level Sight Gauge & Drain Plug

Cabinet Temperature

HP Compressor Filter Canister

Heater Thermostat Control

LP Feed Air Filtration (3 Stage)

Manual Condensate Drain Valves (3)

HP Compressor Lubricant Level Sight Gauge & Drain Plug

LP Manual Condensate Drain Valve

11.0 System Drawing / Schematic

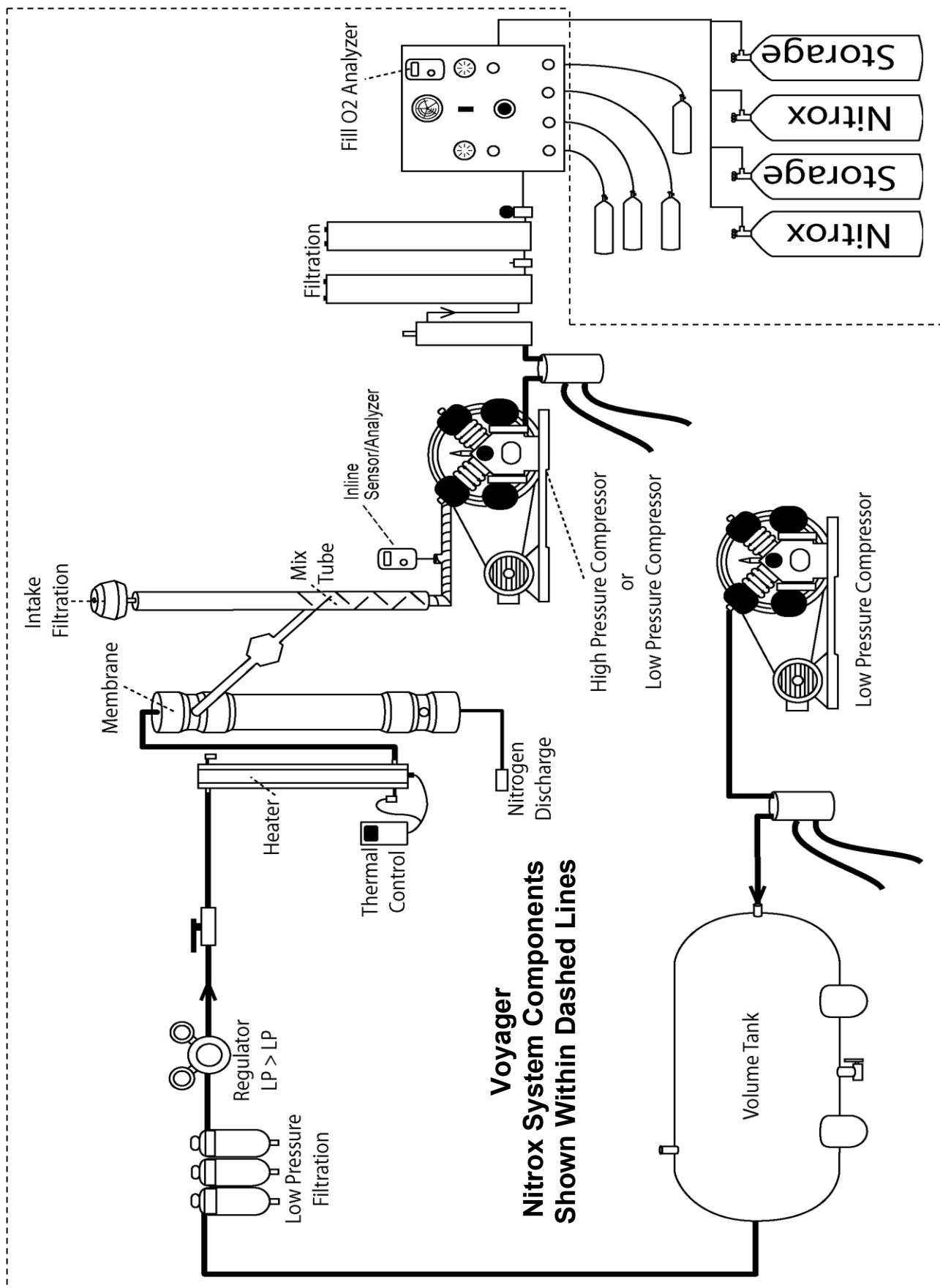

12.0 System Flow Chart

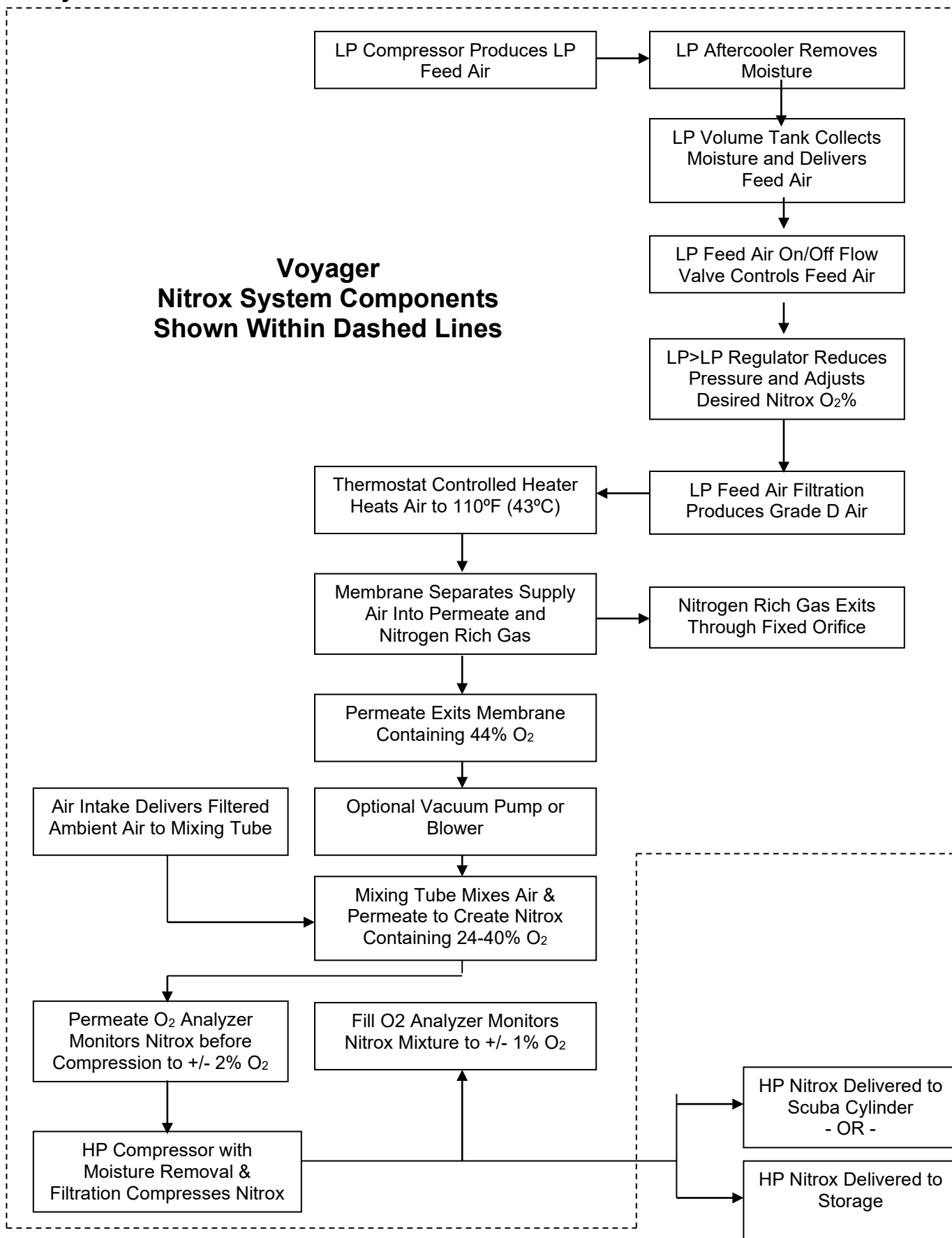

13.0 Installing the Nitrox System



NOTICE

If any information in this manual conflicts with any of the other manuals call Nuvair before proceeding.



CAUTION

Ambient room temperature should never exceed 100°F (38°C) during operation of the Nitrox System. Operation at higher temperatures may lead to system damage and malfunction. A damaged membrane will not produce the correct Nitrox mixture which can lead to severe personal injury if the gas is used for diving purposes without proper analysis.

13.1 Precautions

- 1) Please read all information supplied before physically installing the Nitrox System.
- 2) Unpack the system and remove from the pallet. Visually inspect the system to make sure there has been no damage during shipping. If damaged, please call Nuvair to file a damage report. Please take photos and supply detailed information about the damage.
- 3) Place the system in a location that allows a minimum spacing of 18" from adjacent walls. Select a location where ambient room temperature will never exceed 100°F (38°C).
- 4) The Heater Thermostat has been set in the factory. Do not adjust.

13.2 Attaching Nitrogen Discharge Hose (Optional)

The nitrogen discharge from the Membrane must be isolated from the air intakes of the Membrane System and LP Compressor. This requirement will be met if the Nitrox System is installed in a well-ventilated room that meets industry standards for compressor installations. If the Nitrox System is installed in a closed building, boat, or similar enclosed space, the nitrogen discharge must be vented to the outside. An optional Nitrogen Discharge Hose may be needed. If your installation requires the use of a Nitrogen Discharge Hose, please contact Nuvair for assistance.



Fixed Factory Set
Nitrogen Discharge



DANGER

Pure nitrogen is a colorless, odorless, tasteless gas that will not support life. Breathing gas mixtures containing more than 84% nitrogen at surface pressures will lead to unconsciousness and may cause death.



WARNING

The nitrogen discharge from the Membrane should be vented to a well-ventilated room or to open air with good circulation. Failure to isolate the discharge from the air intake of the Membrane System or LP Compressor could lead to incorrect Nitrox mixtures, resulting in serious personal injury or death. If you allow this pure nitrogen to accumulate in an enclosed space, anyone entering this space will quickly lose consciousness and will die if not immediately resuscitated.

13.3 Electrical Power Connection



WARNING

Never use extension cords to provide power to your Nitrox System. The system must be properly wired according to national and local electrical codes by a qualified electrician. Improper wiring may lead to fires, which can cause serious personal injury or death.

Prior to making the electrical power connection, check all system specifications provided in this manual. When working on the Nitrox System the main breaker at the power source must be “locked out” in the Off position. The Nitrox System has electrical protection for the Compressor Motor and Membrane System Heater located inside the motor starter compartment.

Amperage Load for System

- ◆ Approximately 45 A for 230 V three phase service
- ◆ Approximately 73 A for 230 V single phase service

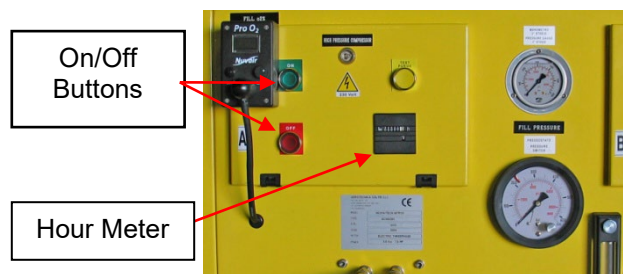

HP Compressor Shown

Compressor Rotation Check

Always turn on (bump) starter for both LP and HP Compressors and run motor very briefly to check for proper direction of rotation (see arrow on belt guard and flywheel).

Note Proper Direction of Rotation



NOTICE

Operation in reverse direction for extended periods of time will cause a Reciprocating Compressor to run hot and perform poorly and may cause permanent damage.

13.4 Air/Nitrox Quality Testing

Before using your Nitrox System to pump Nitrox, test a sample of the Nitrox produced using the Air/Nitrox Quality Analysis Kit provided to verify compliance with CGA standards. Quarterly testing is mandatory once the System is operational.

14.0 Pre-Operation Instructions



WARNING

Do not allow Nitrox to be discharged into the air storage system. Nitrox introduced into the air storage system could cause a diver to suffer from oxygen poisoning at depth. Oxygen poisoning is extremely dangerous and can lead to drowning.



WARNING

Do not allow air to be discharged into the Nitrox storage system. Air introduced into the Nitrox storage system could cause a diver to suffer decompression sickness if the Nitrox mixture is not analyzed properly and is used underwater under the assumption it is a different mix.

14.1 Compressor Lubricant Levels

Check lubricant levels before starting the LP and HP Compressors, and add lubricant as required. Use only the lubricants specified.

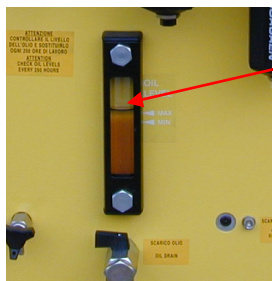

Lubricant Fill Plugs (on top)

Compressor Lubricant Level Sight Gauges

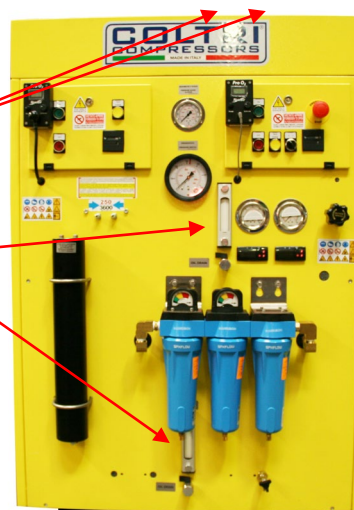

14.2 Membrane System Feed Air Regulator and Switch

An LP>LP Feed Air Regulator is used to reduce feed air pressure to the Membrane System to a typical range of 90 – 165 psi (6-11 bar). An LP Feed Air Switch is used to control the flow of air into the Membrane System. Prepare the Membrane System as follows:

- 1) Reduce feed air pressure to minimum pressure setting by turning the regulator adjustment knob counter-clockwise (CCW) until it spins freely.
- 2) Turn regulator knob clockwise (CW) until you first feel resistance, which means that the spring is starting to compress.
- 3) Make sure the LP Feed Air Switch is in the Off position.

LP Feed Air Regulator Adjustment Knob



LP Feed Air Switch



Oxygen Analyzer Calibration

Gas production may be monitored with the Permeate Oxygen Analyzer before entering the HP Compressor to obtain a rough estimate of %O₂ (+/- 2%); however, do not rely on this reading as an indication of %O₂ at the HP Compressor outlet. Prior to pumping Nitrox into a Scuba cylinder or Surface Supply System, it must be monitored with the Fill Oxygen Analyzer to obtain a precise measurement of %O₂ (+/- 1%). Both Oxygen Analyzers must be calibrated prior to each use.



Permeate Oxygen Analyzer Provides Rough Reading



Fill Oxygen Analyzer Provides Precise Reading

Calibration Knob



WARNING

Oxygen Analyzers must be calibrated before each use. See Oxygen Analyzer manuals for correct calibration procedures. Improper calibration of the Fill Oxygen Analyzer may result in the use of incorrect Nitrox mixtures, which may cause serious injury or death to the diver using the gas mixture.



WARNING

At altitudes above sea level, a correction factor must be used when calibrating the Fill Oxygen Analyzer may not be achievable. See Fill Oxygen Analyzer manual for correcting analyzer readings at various altitudes. Improper calibration of the Fill Oxygen Analyzer may result in the use of incorrect Nitrox mixtures, which may cause serious injury or death to the diver using the gas mixture.



WARNING

The Permeate Oxygen Analyzer supplies oxygen readings that can vary +/- 2% O₂ due to heat, humidity, and pressure changes experienced in the Nitrox flow and therefore should only be used for rough estimates of %O₂. The Fill Oxygen Analyzer supplies more accurate oxygen readings, within +/- 1% O₂. For Scuba cylinder Nitrox fills, the user must always verify the final fill with a third independent Oxygen Analyzer.

Calibrate Oxygen Analyzers as follows:

- 1) Turn off LP Feed Air Switch and return LP Feed Air Regulator to minimum pressure setting by turning adjustment knob CCW until it spins freely.



LP Feed Air Switch



LP Feed Air Regulator Adjustment Knob

- 2) Slightly open fill whip valve on HP Compressor to relieve any residual pressure, and then, if desired, insert clean rag in yoke to act as sound muffler.

Adjust Fill Whip Valve to Maintain Pressure

Insert Clean Rag in Fill Whip Yoke

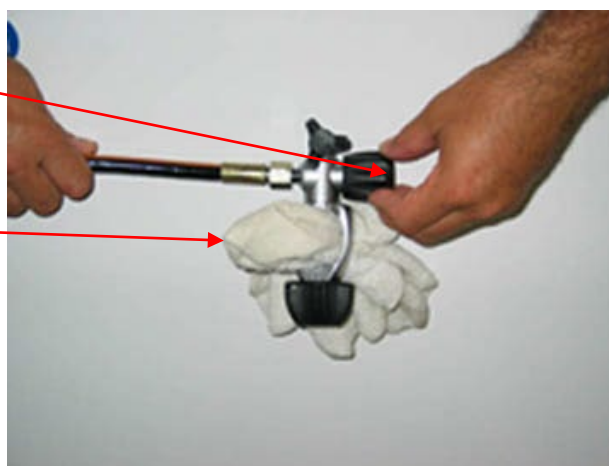

Optional Sound Muffler for HP Nitrox Compressor

- 3) Turn on HP Compressor and drain condensate.

HP Compressor On Button

Dial-A-Pressure Control



- 4) Set Dial-A-Pressure Gauge for desired fill pressure. Adjust fill whip valve so the running HP Compressor maintains 1500-2000 psi (100-140 bar) outlet pressure. Air will now be flowing past both Oxygen Analyzers for calibration purposes.
- 5) Monitor all gauges for proper operating range and check all connections for leaks.
- 6) Calibrate Oxygen Analyzers while the HP Compressor is pumping air. Refer to the Oxygen Analyzer manual included with the Nitrox System for details. Note that special calibration procedures may be required when operating at altitudes above sea level.
 - ◆ Permeate Oxygen Analyzer - Calibrate analyzer so Display reads 20.9%.
 - ◆ Fill Oxygen Analyzer - Calibrate analyzer so Display reads 20.9% to correlate with the Grade E breathing air present at the Sensor. Different settings may be used depending on location, so verify your actual ambient conditions and refer to the Oxygen Analyzer manual for details.

Fill Oxygen Analyzer - Alternate Calibration Method

The Fill Oxygen Analyzer can also be calibrated in ambient air as an alternative. This is especially useful during routine re-calibration while the system is operating. Different settings may be used depending on location, so verify your actual ambient conditions and refer to the Oxygen Analyzer manual for details.

- 1) Remove the Flow Adapter Cap covering the Sensor.
- 2) Expose the Sensor to ambient air for approximately 15 seconds.
- 3) Adjust Calibration Knob until Display reading stabilizes at 20.9%.
- 4) Reinstall the Flow Adapter Cap to the analyzer.
- 5) The Fill Oxygen Analyzer is now ready for use.

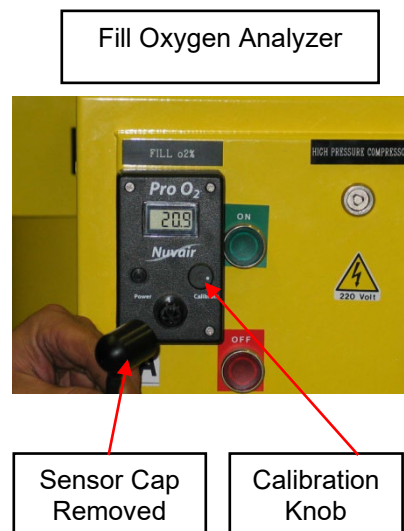

14.3 Attaching Scuba Cylinder



NOTICE

Only one fill whip is attached to a Scuba Cylinder at this point. The second whip will continue to be used to control HP Compressor outlet pressure.

Attach one HP Compressor Fill Whip to a Scuba Cylinder. Leave Cylinder Valve closed.

Additional cylinders or storage tanks can be attached after the system is ready to pump Nitrox.

Fill Whip Attached to Scuba Cylinder

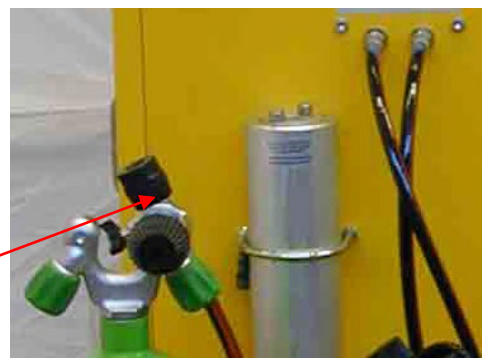

15.0 Producing Nitrox



WARNING

The equipment you will be using to manufacture Nitrox (oxygen rich air) will expose you to both low and high-pressure gas. Gas, even under moderate pressures, can cause extreme bodily harm. Never allow any gas stream to be directed at any part of your body.

15.1 Flow to Membrane

- 1) Verify that Oxygen Analyzer calibration is complete, LP Feed Air Switch is in Off position, and Regulator is at minimum pressure setting.
- 2) Press LP and HP Compressor Purge buttons briefly to remove condensate and bleed pressure.
- 3) Turn on LP Compressor and allow Volume Tank to come up to full pressure of approximately 175 psi (12 bar). The sound will change and the rpm will increase slightly, indicating that the Compressor is unloading.
- 4) Turn on HP Compressor. Set Dial-A-Pressure Gauge for desired fill pressure. Allow pressure to build up to about 2000 psi (140 bar), then crack open the unconnected fill whip to maintain 1500-2000 psi (100-140 bar).
- 5) Verify that Permeate Oxygen Analyzer reads 20.9%.
- 6) Turn on Membrane System by turning LP Feed Air Switch on.

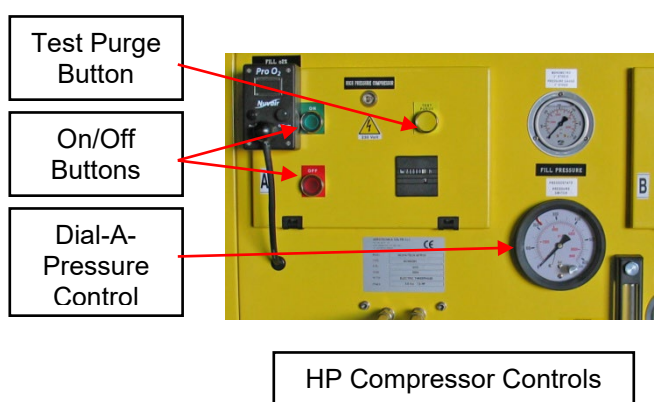
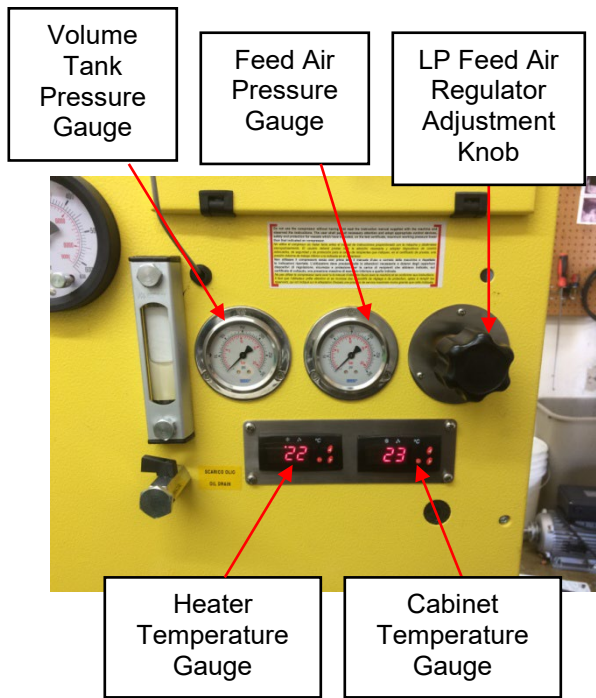
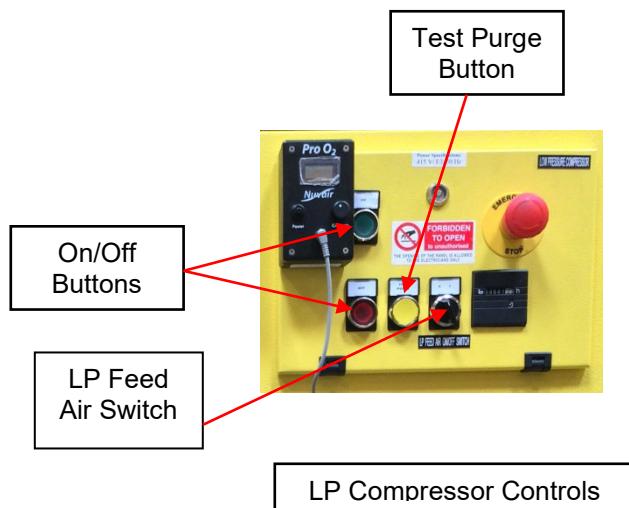

Nuvair Voyager I Nitrox System

- 7) Adjust feed air pressure to approximately 100 psi (7 bar) to activate Heater Pressure Switch. Increase pressure by slowly turning the regulator Knob CW or decrease pressure by turning the Knob CCW. Heater will not turn on until Membrane System is pressurized.



LP Feed Air
Regulator
Adjustment
Knob

- 8) Verify that Heater Thermostat Control green indicator light is on. The light will remain on until operating temperature is reached and will then cycle on and off. When light turns off, check Heater Temperature Gauge to verify air temperature is between 105-120 °F (40-49 °C). At any time that temperature exceeds 120 °F, green indicator light should be off.



NOTICE

The Heater Thermostat Control green indicator light will stay on until operating temperature is reached.



CAUTION

Do not change the temperature setting on the Thermostat Control without contacting Nuvair. Changes in temperature settings may cause Membrane damage. A damaged membrane will not produce the correct Nitrox mixture which can lead to severe personal injury if the gas is used for diving purposes without proper analysis.

- 9) Check Permeate Pressure Gauge to verify that it reads near 0 PSI. A negative or positive pressure reading could indicate blockage.

15.2 Setting Proper Pressure

The Membrane System feed air pressure determines the %O₂ of the Nitrox mixture. As pressure is increased, a higher %O₂ Nitrox is pumped. As pressure is decreased, a lower %O₂ is pumped.

- 1) Increase pressure by slowly turning the regulator Knob CW while monitoring the Pressure Gauges and Permeate Oxygen Analyzer. As the pressure rises, watch the corresponding increase in the analyzer %O₂ reading.
- 2) Increase or decrease pressure slowly until the Permeate Oxygen Analyzer displays the %O₂ desired in the final Nitrox mixture.
- 3) Allow system pressure and temperature to stabilize (approximately 5-8 minutes).
 - ◆ Volume Tank pressure range should be 165-175 psi (11-12 bar).
 - ◆ Regulated Membrane System pressure range should be 90– 165 psi (6-11 bar), depending on Nitrox %O₂ being produced.
 - ◆ Heater temperature range should be 105-120 °F (40-49 °C).



Permeate Oxygen Analyzer



NOTICE

Feed air pressure will never be higher than Volume Tank pressure.

15.3 Final Adjustments Before Pumping Nitrox

- 1) As the Nitrox initially makes its way through the running HP Compressor, the %O₂ reading on the Fill Oxygen Analyzer will slowly increase to read approximately the same %O₂ as the Permeate Oxygen Analyzer. This should happen within 3-5 minutes.
- 2) When the two analyzers read within +/- 1%, make any final adjustments to the Membrane System feed air pressure necessary to obtain the exact Nitrox %O₂ desired as indicated on the Fill Oxygen Analyzer.
- 3) The system is now ready to pump Nitrox.



Fill Oxygen Analyzer

15.4 Pumping Nitrox



WARNING

The use of enriched air Nitrox does not eliminate the risk of decompression sickness (DCS) in diving. Decompression sickness can lead to permanent disability or death.\



WARNING

The Permeate O₂ Analyzer supplies oxygen readings that can vary +/- 2% O₂ due to heat, humidity, and pressure changes in the Nitrox flow and should only be used for rough estimates of %O₂. The Fill O₂ Analyzer supplies more accurate readings, within +/- 1% O₂. For Scuba cylinder fills, the user must always verify the fill with a third independent O₂ analyzer.



WARNING

Do not use this system to produce Nitrox mixtures containing more than 40% oxygen. Pumping Nitrox mixtures with higher concentrations of oxygen may lead to fires or explosions, which can cause serious personal injury or death.



WARNING

Do not pump Nitrox mixtures at pressures above the HP Compressor rating, and never above 3600 PSI (250 bar). The system is not rated for pressures above 3600 PSI (250 bar). Higher pressures may lead to explosions which may cause serious personal injury or death.



NOTICE

No oxygen cleaning of standard cylinders or plumbing is mandatory when using the Nitrox System to produce Nitrox containing a maximum of 40% oxygen. When filling oxygen clean cylinders, hyper-purification of the Nitrox is required using an optional Oxygen Compatible Air purification system available from Nuvair.



DANGER

This Nitrox System does not produce Nitrox mixtures acceptable for 100% oxygen service.



DANGER

Never fill a cylinder that is marked, "For Oxygen Service," with Nitrox that has been produced by anything other than 100% oxygen clean system. Filling an oxygen clean cylinder with breathing gas containing hydrocarbons can lead to explosions if the cylinder is subsequently filled with gas mixtures containing gas mixtures containing greater than 40% oxygen.



WARNING

Only provide Scuba cylinder Nitrox fills to customers who have proof of Nitrox training and certification. Improper use of Nitrox can be fatal.



DANGER

This system is not cleaned for oxygen service and not all components are compatible with gas mixtures containing greater than 40% oxygen. Pumping gas mixtures containing greater than 40% oxygen will lead to explosions which may cause severe personal injury or death.



WARNING

Each Scuba cylinder belonging to a customer must be analyzed by that customer at the Nitrox filling facility, using an oxygen analyzer independent of those used with the Nitrox System. An employee must witness that the customer has properly analyzed the gas in each cylinder, noted the maximum operating depth for that mixture, and signed and dated the fill log. The time of day must also be included with the date, since some customers may fill the same cylinder more than once a day.

Pump Nitrox as follows:

- 1) When filling a Scuba cylinder, follow all industry standards. Do not exceed rated pressure of cylinder, and do not exceed 3600 psi (250 bar) under any condition.
- 2) With fill whip bleed valve open and Nitrox flowing, verify that Fill Oxygen Analyzer %O₂ reading equals the desired Nitrox %O₂.
- 3) Close bleed valve, open cylinder valve, and fill cylinder. Monitor system for proper operation:
 - a) Monitor Oxygen Analyzers and recalibrate as required
 - b) Listen for proper operation of automatic condensate drains every 10-15 minutes.
 - c) Monitor all system gauges as shown in the table below.



NOTICE

The Oxygen Analyzers may require re-calibration after 10-20 minutes of operation due to humidity and temperature change effects on the Sensor. To recalibrate, turn off the LP Feed Air Switch and follow calibration instructions.



NOTICE

When the HP Compressor auto drain engages and dumps condensate, the Fill Oxygen Analyzer reading will decrease momentarily due to the pressure drop in the system. It will return to its previous reading within seconds after the auto drain sequence stops.

GAUGE	RECOMMENDED SETTING
Compressor Gauges	According to manufacturers recommendations
Heater Temperature	105-120° F (40-49° C)
Cabinet Temperature	Less than 100° F (38° C)
Volume Tank Pressure	165-175 PSI (11-12 bar)
Membrane Feed Air Pressure	90 - 165psi (6-11 bar) depending on Nitrox O ₂ %
Fill Oxygen Analyzer	Showing the proper reading for intended fill
Nitrox Storage Pressure	DO NOT exceed rating of tank or 3600 P.S.I (250 bar)

- 4) After filling is complete, close cylinder valve, vent the bleed valve, and remove the cylinder.
- 5) Test the Nitrox %O₂ in the cylinder using an independent Oxygen Analyzer such as the Nuvair O₂ Quickstick™. Calibrate analyzer before use in accordance with manufacturer's instructions.
- 6) Repeat steps 1-5 until you have filled all Scuba cylinders.
- 7) Mark each tank with fill date, %O₂, fill pressure, and MOD (Maximum Operating Depth).



Use Independent Oxygen Analyzer for Verification

- 8) Log every Nitrox fill to document the following information:
 - ◆ Fill date and time of day
 - ◆ Tank Number
 - ◆ Supplier's check of oxygen content (%O₂) plus signature and date
 - ◆ User's check of oxygen content (%O₂) plus signature and date
 - ◆ Fill Pressure
 - ◆ MOD (Maximum Operating Depth) in user's handwriting
 - ◆ Nitrox certifying agency and card number
- 9) When filling a HP Nitrox storage tank, verify that Fill Oxygen Analyzer %O₂ reading equals the desired Nitrox %O₂. Open applicable line valves and tank valve, and fill with Nitrox. Do not exceed rated pressure of cylinder, and do not exceed 3600 psi (250 bar) under any condition. After filling is complete, close all valves and allow Nitrox System to shut down.

15.5 Pumping Air

To use the System to pump air, simply turn off the LP Compressor and LP Feed Air Switch. No Nitrox will be supplied to the HP Compressor, and it will pump air only. When the HP Compressor is pumping air, the Permeate Oxygen Analyzer and the Fill Oxygen Analyzer should both read 20.9% O₂.

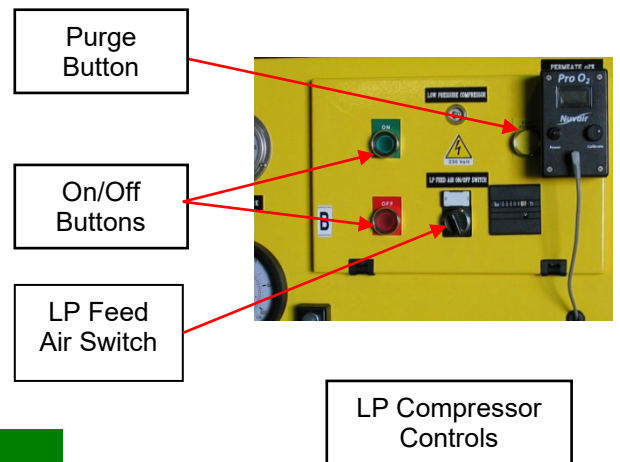

NOTICE

Always use Oxygen Analyzers to monitor oxygen content of any gas flowing through the System. Both air and Nitrox are subject to variations in oxygen content.

15.6 Shutting Down

- 1) When tank filling is complete and tank valves are closed, the Nitrox System will automatically shut down at the pressure set on the Dial-A-Pressure Gauge.
- 2) Manually shut off the Membrane System by turning the Feed Air Regulator adjustment knob CCW to reduce pressure to minimum setting and then turning off LP Feed Air Switch.
- 3) The system will automatically drain all Filter, Compressor, and Volume Tank condensate.

16.0 Nitrox Operation Notes

16.1 Correlation of Feed air Pressure to Oxygen Content

After the 10 hour break-in period for your Nitrox System, you will notice that specific Nitrox %O₂'s always match specific feed air pressures once the System has warmed up. These pressures will be repeatable. If you find that the Fill Oxygen Analyzer reads 36% O₂ when the feed air pressure is at 125 psi (9 bar), record this pressure or make a mark on the feed air pressure gauge indicating the %O₂. Do this for each %O₂ that you normally make, making sure System has warmed up first. The next time Nitrox with 36% O₂ is needed, adjust the regulator to 125 psi (9 bar) and wait for the Oxygen Analyzer reading to stabilize. You will find the analyzer reading to be very close to 36% O₂, requiring only minor adjustments of the regulator to achieve the exact desired %O₂.



NOTICE

Use the Fill Oxygen Analyzer to verify the Nitrox oxygen percentage prior to pumping. When using the feed air pressure reading to obtain specific oxygen percentage, minor adjustments of the feed air pressure regulator may be required to obtain the exact percentage desired.

16.2 Hot Fills

While in the process of filling HP Nitrox Storage Tanks, you may have a need to supply a walk-in customer with a Scuba Cylinder fill of a different Nitrox mix. You can change mixes as follows:

- 1) With the Nitrox System operating, isolate the HP Nitrox Storage Tanks from the HP Compressor by closing the appropriate valves.
- 2) Record the Membrane System feed air pressure reading.
- 3) Slightly open fill whip valve on the HP Compressor, and adjust so the running Compressor maintains 1500-2000 psi (100-140 bar) outlet pressure.
- 4) Adjust the feed air regulator to the pressure corresponding to the desired Nitrox %O₂ for the Scuba Cylinder fill.
- 5) Allow the Fill Oxygen Analyzer reading to stabilize, make any minor adjustments necessary to achieve the desired %O₂, and then fill cylinder in normal manner.
- 6) When finished return regulator to previous setting, and allow the Fill Oxygen Analyzer reading to stabilize. Make any minor adjustments necessary to achieve the desired %O₂, and then resume filling Storage Tanks.

17.0 Maintenance

The following list of daily and routine maintenance items is intended as a guide. Refer to LP and HP Compressor manuals for complete maintenance requirements.

17.1 Daily Maintenance



CAUTION

Be sure to check Compressor Lubricant levels prior to each day of operation. Failure to ensure the proper lubricant level will lead to system damage.

- 1) Check lubricant levels of both LP and HP Compressors and add proper lubricants as required. See Section 17.3 and Compressor manuals for details.
- 2) Operate LP and HP Purge Buttons to verify proper operation of automatic condensate drain valves, then slightly open each HP and LP Manual Condensate Drain Valve to verify that no condensate is present.
- 3) Check LP Air Filtration for condensate and proper operation of condensate drains.

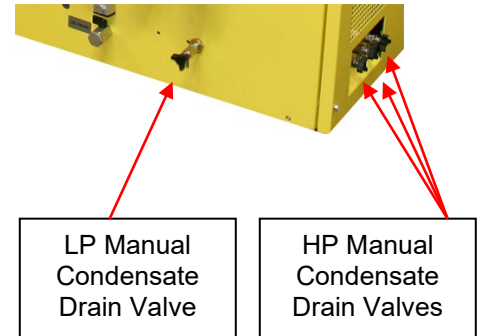

17.2 Routine Maintenance



WARNING

Use only the specified Nuvair Lubricants in this system. The use of incompatible lubricants presents a risk of fire and/or explosion, and may result in system damage. This can lead to severe personal injury and death.



WARNING

Be sure that all pressure has been relieved from the system prior to opening any filtration canister. Failure to vent pressure from the system prior to opening the canister can lead to serious personal injury or death.



CAUTION

If system is located in an area where there is high humidity and high heat, the life of all Filtration Elements may be as little as 35% of rated operating capacity. Check the Compressor manual and Appendix for details on Filter Element Life Factors.

- 1) LP Compressor Lubricant: Change Compressor Lubricant every 200 hours. Only use lubricants rated for use with Nitrox, such as Nuvair 455. Never mix Compressor Lubricants. See Section 17.3 and LP Compressor manual for details.
- 2) HP Compressor Lubricant: Change Compressor Lubricant every 100 hours or annually, whichever comes first. Only use lubricants rated for use with Nitrox, such as Nuvair 455. Never mix Compressor Lubricants. See Section 17.4 and HP Compressor manual for details.

- 3) LP Air Filtration Inspection: On a weekly basis, inspect each Filter Bowl for the presence of moisture and each Element for any unusual degradation or wetness. See Section 17.5 for details.
- 4) LP Air Filtration Elements: Change LP Filter Elements every 100 hours to maintain CGA Grade D air standards. Visual liquid level and service life indicators assist with monitoring replacement intervals. See Section 17.5 for details. If the Nitrox System is operated in high humidity and/or high temperature, Filter Elements must be changed more often. See Appendix for details on Filter Element Life Factors.
- 5) HP Compressor Filtration Element: Change HP Filter Element every 13,000 cu ft of air or Nitrox processing to maintain CGA Grade E air standards. See Section 17.6 for details. If the Nitrox System is operated in high humidity and/or high temperature the Filter Element must be changed more often. See Appendix for details on Filter Element Life Factors.
- 6) Condensate Drain Container: Check level and drain weekly or as needed.
- 7) Semi-Permeable Membrane: No maintenance required. Service life exceeds 20 years if LP Air Filtration is properly serviced to maintain Grade D standards.
- 8) Membrane System Air Intake Filter: Inspect filter element every 3 months for visible particles. Change every 12 months or sooner if particles are visible.
- 9) Oxygen Analyzers: Replace Oxygen Sensor and Battery as required. See manual included with Nitrox System.

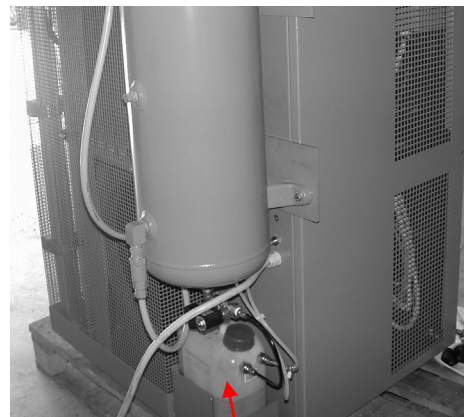

Condensate Drain Container.
Check & Drain Weekly.



DANGER

Do not swallow (ingest) either the electrolyte from the Oxygen Sensor or the Sensor itself. The Potassium Hydroxide chemical contained in the Sensor can cause severe injury or death. If electrolyte or the Sensor is swallowed, seek medical attention immediately.



DANGER

If after handling the Oxygen Analyzer or Sensor, you find that your fingers or other parts of your body feel “slippery” or the skin or eyes sting, immediately flush affected area with clean, fresh water for at least 15 minutes. The stinging or slippery sensation is an indication of a leaking Sensor. The Potassium Hydroxide chemical contained in the Sensor can cause severe injury or death. Seek immediate medical attention if eye contact is made or skin stinging persists.

- 10) Air/Nitrox Quality Analysis: Take breathing air/Nitrox samples quarterly for analysis to assure compliance with CGA Grade E breathing air standards.

17.3 Compressor Lubricant

The LP and HP Compressors in your Nitrox System comes standard with Nuvair 455 Synthetic Food Grade Compressor Lubricant. Check lubricant levels at each Sight Gauge and add lubricant as required through the appropriate Fill Plug. Lubricant is removed through the Drain Plugs. See LP and HP Compressor manuals for details on servicing Lubricant.

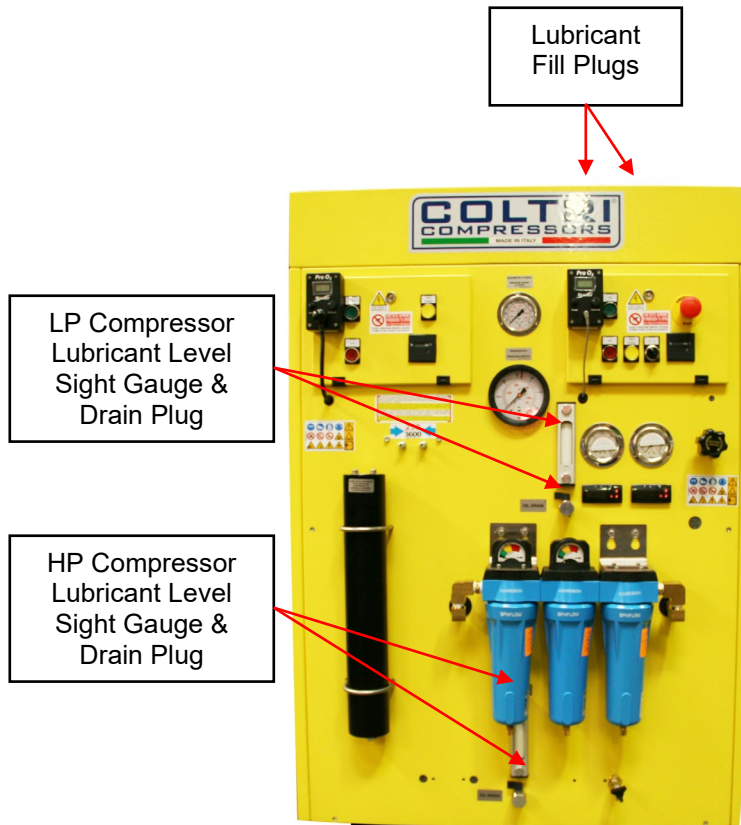

17.4 LP Feed Air Filtration



CAUTION

Special attention needs to be given to the arrangement of the LP Feed Air Filtration Elements and Bowls. Properly reinstall each Element and Bowl to the correct Housing. Improper sequence can cause damage to downstream components

The use of Grade D or better feed air is critical to prevent the passing of any residual oil vapor into the Membrane System. Three stages of the Hankison LP filtration are used to produce Grade D air:

- 1) Particle Removal to 1 micron
- 2) Coalescing & Water/Oil Vapor Removal to 0.01 micron
- 3) Oil Vapor Removal to 0.003 PPM

LP Filtration Inspection

Open each Filter and inspect as follows:

- 1) Inspect Bowl for the presence of moisture. A high level of moisture build-up in the HF7 or HF5 Filter indicates improper operation of auto-drain floats. Any evidence of moisture in the HF1 Filter indicates the air is not cooling properly and moisture is not properly being removed. Excess moisture will prevent the final filter from operating properly.
- 2) Inspect Elements for any unusual degradation or wetness. Element degradation can indicate more serious problems. Contact Nuvair for assistance.

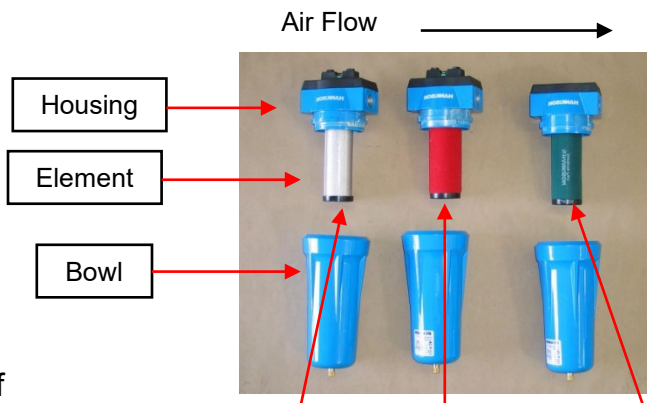

HF7-16	HF5-16	HF1-16
Particle Removal	Coalescing & Water/Oil Vapor Removal	Oil Vapor Removal
Replacement Element Part Number		
E7-16	E5-16	E1-16

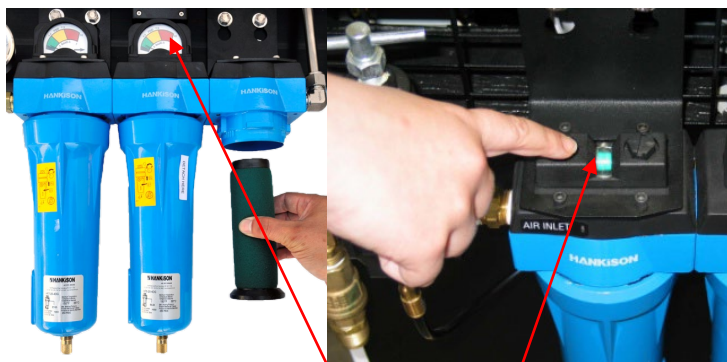

DP Indicator Changes from Green to Red. Yellow indicates filter needs to be replaced.
Do Not Use When Red.

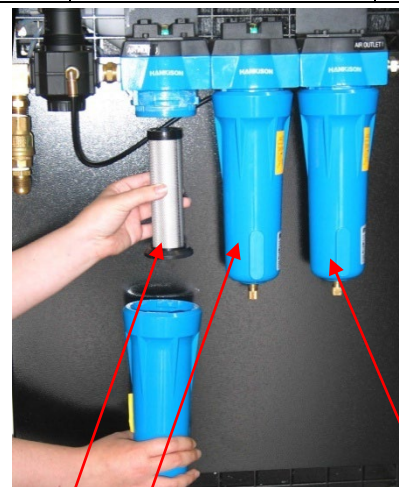

HF7 & HF5 Filters with Auto-Drain Floats & DP Indicators.

HF1 Filter with Manual Drain – Should not Contain Moisture

Changing LP Filtration Elements

Change the LP Filter Elements **every 100 hours or once per year***. If the Compressor System is operated in high humidity and/or high temperature, Filter Elements must be changed more often. Visual DP indicators on the HF7 and HF5 filters assist with monitoring replacement intervals.

- 1) Push up on the Bowl, rotate CCW, and lower to remove.
- 2) Gently rotate Filter Element and pull down off mounting post.
- 3) Replace Element and reassemble in reverse order.



Changing LP Filtration Element



NOTICE

The interior of the Filter Bowls can be cleaned with a diluted solution of Simple Green™ and flushed thoroughly with clean water. This will assist to prolong the life of the element, bowl, and auto drain.

17.5 HP Compressor Filtration

The HP Compressor comes standard with Triplex filtration, utilizing a single Filter Element. Do **NOT** use any substitute. Change Filter Element every 13,000 cu ft of air or Nitrox processing. If the Nitrox System is operated in high humidity and/or high temperature, Filter Element must be changed more often. See Appendix for details on Filter Element Life Factors.

- 1) Shut down the Nitrox System
- 2) Open Manual Condensate Valves to drain pressure. Leave Valves open.
- 3) Unscrew the Filter Canister Cap per the HP Compressor manual.
- 4) Remove expended Element from Filter Canister and unscrew from Canister Cap.
- 5) Install new Element to Canister Cap and reinstall Cap to Canister.
- 6) Close Manual Condensate Valves.

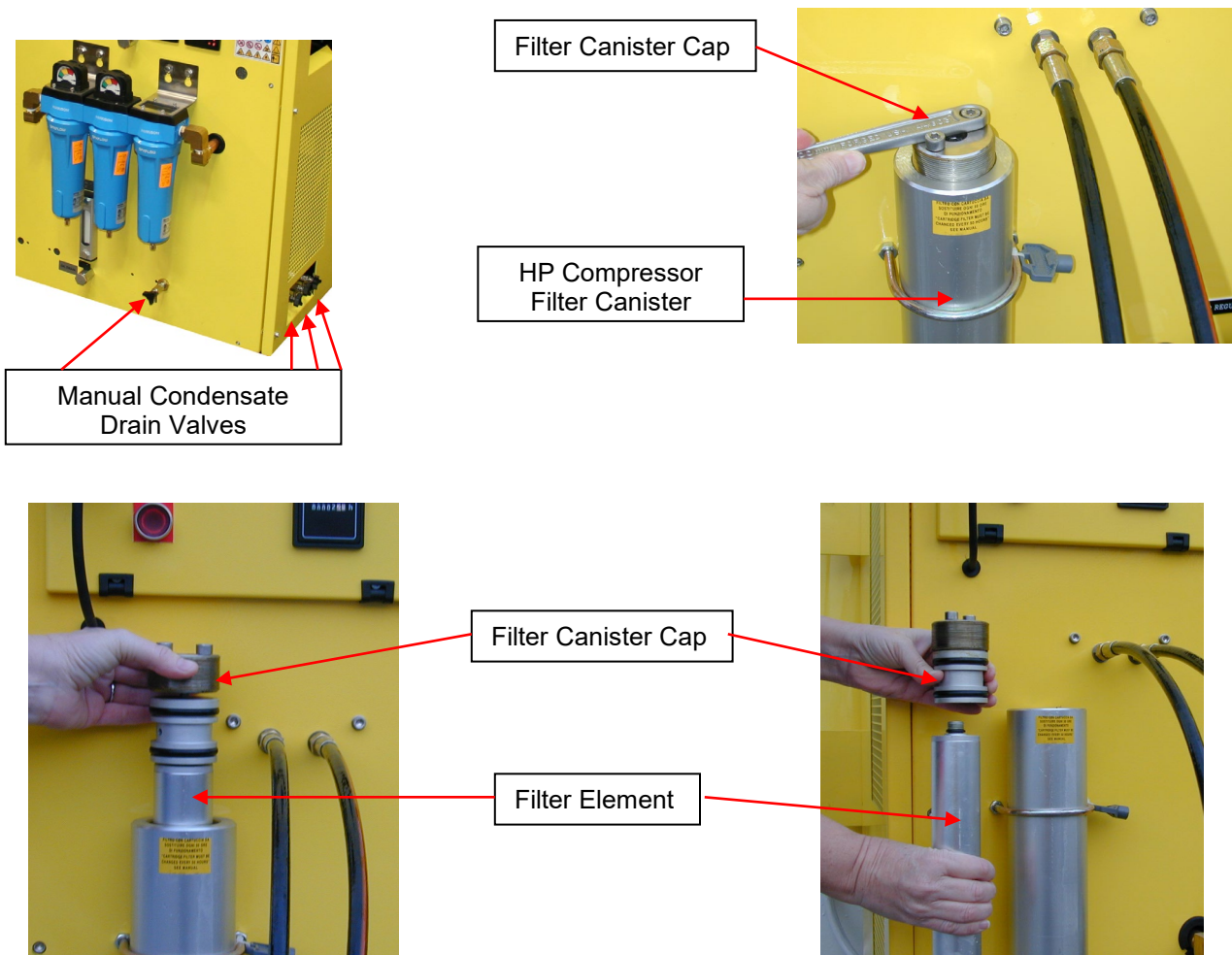

17.6 Spare Parts List

See LP and HP Compressor manuals for Compressor parts lists. Other Nitrox System components and related items are listed below.

Nitrox System Components	Type	Part Number
Reciprocating Compressor Lubricant, Food Grade, Nitrox Compatible	Nuvair 455, 1 Gal (Other Sizes Available)	9406
LP Filtration Element	Hankison HF 7-16	E7-16
	Hankison HF 5-16	E5-16
	Hankison HF 1-16	E1-16
HP Compressor Filtration Element	Breathing Air, Grade E	X302414
Heater Assembly	1200 Watt, 28" Length	H1200
Heater Thermostat Control	110V/220V	A419
Heater Pressure Switch		3100-052
Membrane	230 Series	NUV230
Air Intake Filter Element	10-16 CFM	16CP
Mixing Tube Assembly	1.5 inch diameter, specify length	
Oxygen Analyzer	Pro O ₂	9450
	Pro O ₂ Remote	9452
Oxygen Sensor	See Analyzer Owners Manual	
Compressor Hose Coupler	1-1/4"-1-1/2" to 1-1/4"-1-1/2"	PTC-150
	1-1/4"-1-1/2" to 1-1/2"	RDTC40X32
Related Equipment Components		
Air/Nitrox Quality Analysis Kit	Specify: (1) CGA Grade Required	
	(2) Single Use or Program Use	

17.7 Service Record Log

Date	Technician Name	Service Performed

Appendix

Supply and Breathing Air Specifications

All supply and breathing air must meet the following requirements of CGA G-7.1-1997. Supply air delivered to the Membrane System must be purified to meet Grade D or E quality, and periodic air quality testing to assure compliance is recommended. All breathing air for diving produced by the downstream Compressor must be purified to meet Grade E quality, and periodic air quality testing to assure compliance is mandatory.

Item	Grade D	Grade E
Oxygen	19.5-23.5%	20-22%
Carbon Dioxide (maximum)	1000 PPM	1000 PPM
Carbon Monoxide (maximum)	10 PPM	10 PPM
Hydrocarbons (maximum)	Not specified	25 PPM
Water Vapor (maximum)	Not specified	Not specified
Dew Point (maximum) (1)	Not specified	Not specified
Oil & Particles (maximum) (2)	5 mg/m ³	5 mg/m ³
Odor	None	None

Notes: (1) Dew Point of supply air must be >10°F (6°C) colder than coldest ambient air expected
 (2) Supply air delivered to the Membrane System must contain <0.003 PPM Oil Vapor

All breathing Nitrox produced for diving must be purified to meet these same requirements, except for oxygen content. Nitrox oxygen content must measure within +/- 1% O₂ of the specified value of the mixture using a properly calibrated Oxygen Analyzer (i.e. Nitrox produced with a target content of 32% O₂ must measure in the range of 31-33% O₂). Periodic air quality testing to assure compliance is mandatory.

Filter Element Life Factors

Breathing air filter element life is typically rated by manufacturer based on an air temperature of 80°F at the filter inlet. Under normal operation this temperature is 12°F (5°C) warmer than the ambient air, resulting in an equivalent ambient temperature rating at 68°F (20°C).

To determine element life at a different ambient temperature, multiply the rated life by the life factor listed below:

Filter Temperature	Ambient Temperature	Filter Element Life Factor
53°F (12°C)	41°F (5°C)	2.6 x Life
62°F (17°C)	50°F (10°C)	1.8 x Life
71°F (23°C)	59°F (16°C)	1.35 x Life
80°F (27°C)	68°F (20°C)	1 x Life
89°F (32°C)	77°F (25°C)	0.8 x Life
96°F (36°C)	84°F (29°C)	0.55 x Life
105°F (41°C)	93°F (34°C)	0.45 x Life
114°F (46°C)	102°F (39°C)	0.35 x Life

CO₂ Scrubber Guide

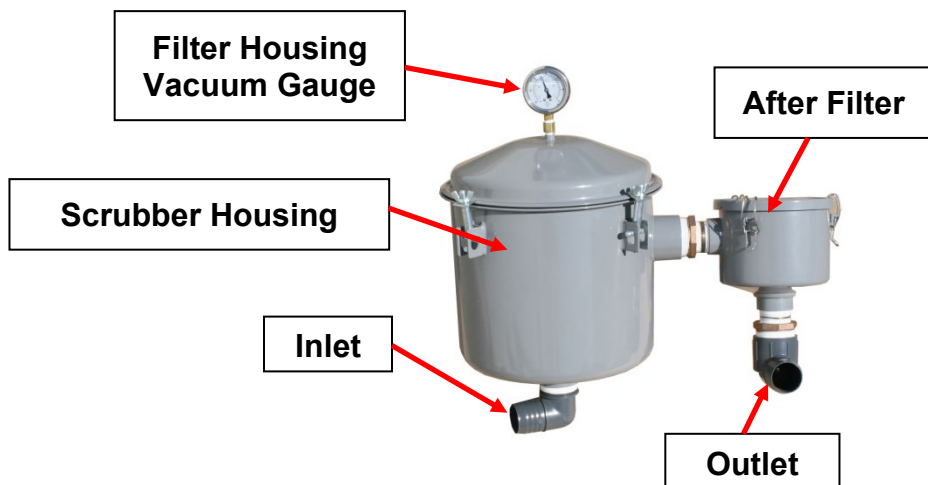

Inner Sofnolime Housing
Holds 3 gallons (11.3 liters)
or 17.5 Lbs (7.9 kilograms)

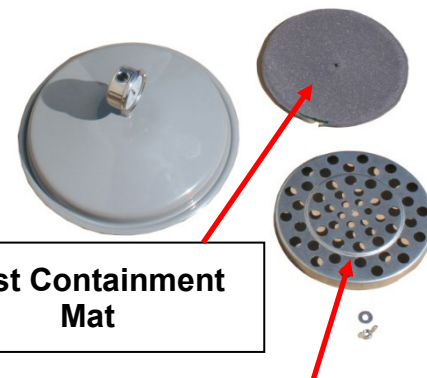

Sofnolime
Housing Lid

- The CO₂ Scrubber is equipped with:
- A. Outer Scrubber Housing
 - B. Scrubber Housing Vacuum Gauge
 - C. Inner Sofnolime (CO₂ Absorber Media) Containment Housing
 - D. Dust Containment Mat
 - E. Perforated Sofnolime Containment Housing Lid
 - F. After Filter

NOTE: The Sofnolime media should be changed any time a significant rise in CO₂ level is indicated by calibrated analyzer.

When filling the Sofnolime Containment Housing, take care not to spill media between it and the Outer Scrubber housing. When re-installing the Outer Scrubber Housing Lid, ensure that the large o-ring is properly seated.

When reassembling the Inner Sofnolime Containment Housing after initial fill or media change, ensure that the Dust containment mat is in place under the Perforated Lid.

If a rise in Vacuum in the Scrubber Housing is indicated, the Sofnolime media has been compromised or a blockage has occurred prior to the Scrubber Housing.

When the Sofnolime media is changed, the After Filter element should be inspected for cleanliness and water saturation. If there is an excess of media dust or water present, the filter element is compromised and should be changed.

Shown: Inner Sofnolime
Housing Assembled



CONTACT NUVAIR FOR REPLACEMENT PARTS

OWNER'S WARRANTY RESPONSIBILITIES

Failure of the owner to prevent equipment damage by complying with the procedures outlined below and in the Operation Manual will void the Nitrox System warranty.

Installation:

- All set up requirements and procedures provided in the Nitrox System Operation Manual must be followed in their entirety including supply air cleanliness, Compressor preparation, and installation of the Nitrox System.
- Supply air to the Membrane must be properly filtered to CGA Grade D air quality or better to prevent damage to the Membrane. Air quality testing of the supply air should be performed periodically and documented to assure compliance.
- If there is any doubt regarding the suitability of a HP or LP Compressor for compressing Nitrox, contact Nuvair or the Compressor manufacturer before you connect your Nitrox System.
- If an existing HP or LP Compressor is to be used for compressing Nitrox, all traces of the old lubricant must be removed and replaced with a Nitrox Compressor Lubricant approved by Nuvair.
- Electrical wiring and connections should be made by a qualified electrician in accordance with all national and local electrical codes.
- Do not change the temperature setting on the Heater Thermostat Control. Changes in temperature settings may cause Membrane damage.
- To prevent Compressor damage, only use the Compressor Intake Hose provided. If a longer hose is required, contact Nuvair for assistance.
- Compressors must be provided adequate ventilation to operate properly and prevent heat damage. This requires an ambient temperature below 100°F (38°C), sufficient clearance from adjacent walls, and proper rotation direction.

Operation:

- Do not use the Nitrox System to supply a HP or LP Compressor with Nitrox mixtures containing more than 40% oxygen. Compressing higher concentrations of oxygen may cause severe Compressor damage.
- Do not pump Nitrox mixtures at pressures above the Compressor manufacturer's rating, and never above 3600 PSI (250 bar). Compressing Nitrox at higher pressures may cause severe HP Compressor damage.
- To prevent Membrane damage, drain all low pressure filter and volume tank condensate on a daily basis.
- If you become aware of an operational fault, stop using the equipment immediately and contact Nuvair for assistance.

Maintenance:

- Change low pressure filter elements on a schedule determined by filter capacity and ambient temperature and humidity. Contact Nuvair if you need assistance establishing a schedule for your equipment and location.
- Replace Membrane System Air Intake Filter on a regular basis to prevent flow obstruction.
- Keep all nuts, bolts, fittings, connectors, and clamps tight.
- Keep a service record book showing that regular maintenance work has been carried out. If a warranty claim becomes necessary, it will aid in demonstrating that damage has not been caused by insufficient maintenance. Proof of maintenance may be required prior to determining the validity of a warranty request.

NUVAIR NITROX SYSTEM WARRANTY

NUVAIR extends a limited warranty, which warrants the Nitrox System to be free from defects in materials and workmanship under normal use and service for a limited period. The specific Membrane Component of the Nitrox System is warranted according to the pro-rated terms as set forth below. All other Original Equipment Manufacturer (OEM) components used in the system are warranted only to the extent of the OEM's warranty to NUVAIR. NUVAIR makes no warranty with respect to these OEM components, and only warrants the workmanship that NUVAIR has employed in the installation or use of any OEM component. This warranty is not transferable.

NUVAIR will, at its discretion and according to the terms as set forth within, replace or repair any materials which fail under normal use and service and do not exhibit any signs of improper maintenance, misuse, accident, alteration, weather damage, tampering, or use for any other than the intended purpose. Determination of failure is the responsibility of NUVAIR, which will work together with the customer to adequately address warranty issues. When any materials are repaired or replaced during the warranty period, they are warranted only for the remainder of the original warranty period. This warranty shall be void and NUVAIR shall have no responsibility to repair or replace damaged materials resulting directly or indirectly from the use of repair or replacement parts not approved by NUVAIR.

Pro-Rated Terms:

NUVAIR warrants the Membrane Component of the Nitrox System to be free from defects in material and workmanship for a period of thirty-six (36) months from date of installation or forty-two (42) months from date of shipment by NUVAIR, whichever may occur first. The warranty covers parts only and is prorated as follows:

- First Year Repair or replacement free of charge
- Second Year Warranty allowance of 70% of the current Membrane Component list price
- Third Year Warranty allowance of 40% of the current Membrane Component list price

A warranty registration card, supplied with system documentation, must be filled out and submitted to NUVAIR for the warranty to be in full effect. If the warranty registration card is not received within thirty (30) days of installation, the thirty-six (36) month warranty will begin with the date of shipment from NUVAIR. For warranty service to be considered, customer's account must be current or paid in full.

Maintenance Items:

Any materials which are consumed, or otherwise rendered not warrantable due to processes applied to them, are considered expendable and are not covered under the terms of this policy. This includes maintenance and consumable items listed as part of a suggested maintenance program included with system documentation.

Return Policy:

Application for warranty service can be made by contacting NUVAIR during regular business hours and requesting a Return Material Authorization number. Materials that are found to be defective must be shipped, freight pre-paid, to the NUVAIR office in Oxnard, California. Upon inspection and determination of failure, NUVAIR shall exercise its options under the terms of this policy. Warranty serviced materials will be returned to the customer via NUVAIR's preferred shipping method, at NUVAIR's expense. Any expedited return shipping arrangements to be made at customer's expense must be specified in advance.

Limitation of Warranty and Liability:

Repair, replacement or refund in the manner and within the time provided shall constitute NUVAIR'S sole liability and the Purchaser's exclusive remedy resulting from any nonconformity or defect. NUVAIR shall not in any event be liable for any damages, whether based on contract, warranty, negligence, strict liability or otherwise, including without limitation any consequential, incidental or special damages, arising with respect to the equipment or its failure to operate, even if NUVAIR has been advised of the possibility thereof. NUVAIR makes no other warranty or representation of any kind, except that of title, and all other warranties, express or implied, including warranties of merchantability and fitness for a particular purpose, are hereby expressly disclaimed. No salesman or other representative of NUVAIR has authority to make any warranties.



Nuvair
Phone +1.805.815.4044
Fax +1.805.486.0900
Address 1600 Beacon Place
Oxnard, CA 93033 USA
Email info@nuvair.com
Website www.Nuvair.com